



OPERATORS MANUAL
WLP-SERIES
(AFTER SERIAL #30008260)
WATER RECYCLING TREATMENT SYSTEM



CAUTION

RISK OF INJURY!

READ MANUAL BEFORE OPERATING!

This manual is an important part of the water recycling treatment system and must remain with the unit when you sell it!

CONTENTS

INTRODUCTION	3
CONTENTS OF WLP-SERIES WATER RECYCLING TREATMENT SYSTEM.....	4
SPECIFICATIONS.....	4
IMPORTANT SAFETY WARNINGS.....	5
RISK OF ELECTRIC SHOCK OR ELECTROCUTION.....	5
RISK OF EXPLOSION OR FIRE.....	6
RISK OF BURSTING	6
RISK OF BURNS	6
RISK FROM MOVING PARTS.....	7
RISK OF BODILY INJURY	7
WATER RECYCLING TREATMENT SYSTEM FLOW CHART	8-9
PREPARATION	16
ATTIRE:.....	16
PRE-OPERATION CHECKLIST	19
PRESTART PROCEDURES:	20
START-UP:.....	20
PH AND ORP CONTROL SYSTEM:.....	21
INSTALLATION	22
INSTALLATION OF PH AND ORP PROBES:	22
PH SENSOR PROBE.....	22
ORP SENSOR PROBE	22
OPERATION	28
FINAL PH AND ORP SYSTEM SETUP:.....	28
SETTING OF THE WATER RECYCLING TIMER:.....	28
BEGIN:.....	28
WATER RECYCLING TIMER	28
MAINTENANCE	29
WASTE OIL DECANter:.....	29
SOLIDS COLLECTION AREA:.....	29
BACKWASHING OF FILTERS:	29
WASTE OIL DECANter.....	29
MAINTENANCE.....	30
CARTRIDGE FILTER.....	30
ACTIVE CARBON TEST:	31
REMOVING & REFILLING MEDIA FROM THE MULTIMEDIA & POLISHING FILTER:.....	32
WATER TESTING.....	33
WINTERIZING:.....	35
TROUBLESHOOTING	36-40
REPLACEMENT PARTS	40

⚠ WARNING

⚠ **WARNING:** This product can expose you to chemicals including Lead, which is known to the State of California to cause cancer and birth defects or other reproductive harm. For more information go to www.P65Warnings.ca.gov

⚠ WARNING

⚠ **WARNING:** This product can expose you to chemicals including carbon monoxide, which is known to the State of California to cause birth defects or other reproductive harm. For more information go to www.P65Warnings.ca.gov

INTRODUCTION

Congratulations on the purchase of your new Mi-T-M Water Recycling Treatment System! You can be assured your new Mi-T-M Water Recycling Treatment System was constructed and designed with quality and performance in mind. Each component has been rigorously tested to ensure the highest level of acceptance.

This operator's manual was compiled for your benefit. By reading and following the simple safety, installation, operation, maintenance and troubleshooting steps described in this manual, you will receive years of trouble free operation from your new water recycling treatment system. The contents of this manual are based on the latest product information available at the time of publication. Mi-T-M reserves the right to make changes in price, color, materials, equipment, specifications or models at any time without notice.

! IMPORTANT !

These paragraphs are surrounded by a "SAFETY ALERT BOX". This box is used to designate and emphasize Safety Warnings that must be followed when operating this water recycling treatment system.

Accompanying the Safety Warnings are "signal words" which designate the degree or level of hazard seriousness. The "signal words" used in this manual are as follows:

DANGER: Indicates an imminently hazardous situation which, if not avoided, WILL result in death or serious injury.

WARNING: Indicates a potentially hazardous situation which, if not avoided, COULD result in death or serious injury.

CAUTION: Indicates a potentially hazardous situation which, if not avoided MAY result in minor or moderate injury.



The symbols set to the left of this paragraph are "Safety Alert Symbols". These symbols are used to call attention to items or procedures that could be dangerous to you or other persons using this equipment.

ALWAYS PROVIDE A COPY OF THIS MANUAL TO ANYONE USING THIS EQUIPMENT. READ ALL INSTRUCTIONS BEFORE OPERATING THIS WATER RECYCLING TREATMENT SYSTEM AND ESPECIALLY POINT OUT THE "SAFETY WARNINGS" TO PREVENT THE POSSIBILITY OF PERSONAL INJURY TO THE OPERATOR.

Once the unit has been uncrated, immediately write in the serial number of your unit in the space provided below.

SERIAL NUMBER _____

Inspect for signs of obvious or concealed freight damage. If damage does exist, file a claim with the transportation company immediately. Be sure that all damaged parts are replaced and that the mechanical and electrical problems are corrected prior to operation of the unit. If you require service, contact Mi-T-M Customer Service.

CUSTOMER SERVICE

CALL OUR TOLL-FREE NUMBER

for the Sales or Service Center nearest you!

800-553-9053

Please have the following information available for all service calls:

1. Model Number
2. Serial Number
3. Date and Place of Purchase

CONTENTS OF WLP-SERIES WATER RECYCLING TREATMENT SYSTEM

Carefully unpack your new Mi-T-M WLP-Series Water recycling treatment system. Check the contents against the packing list. Contact the freight line if a damage claim is required on any component. The following items are the basic equipment sent with your WLP-Series Water recycling treatment system.

1. Sump Pump
2. Three Unattached Floats for Sump Pit
 - a. Blue: Protects sump pump low level.
 - b. Red: To fill pit from the water recycling treatment system.
 - c. Green: High pit level discharge.
3. Water recycling treatment system Platform
 - a. Ozone Generator
 - b. Oil/Water/Solids Separator
 - c. Filter Pump
 - d. Flow Meter
 - e. Multi-Media Filter
 - f. Cartridge Filter
 - g. Polishing Filter
 - h. Transfer Pump
 - i. Pressurized Water Storage Tank
4. Water Test Kit
5. Manual

SPECIFICATIONS

MODEL	WLP-08-0M10	WLP-20-0M10	WLP-40-0M10
MAX FLOW	8 GPM	20 GPM	40 GPM
ELECTRICAL	230 VOLT 1 PHASE 21 AMPS	230 VOLT 1 PHASE 22 AMPS	230 VOLT 1 PHASE 25 AMPS
SUMP PUMP	1 HP	1 HP	1 HP
OIL/WATER/SOLID SEPARATOR CAPACITY	95 GALLONS	152 GALLONS	340 GALLONS
OIL COALESCING GRID	288 SQUARE FEET	576 SQUARE FEET	1152 SQUARE FEET
FILTER PUMP (CENTERIFUGAL)	1 1/2 HP	1 1/2 HP	1 1/2 HP
MULTI-MEDIA FILTER	350 LBS	525 LBS	900 LBS
CARTRIDGE FILTER	100 SQUARE FEET 30 MICRON	400 SQUARE FEET 30 MICRON	400 SQUARE FEET 30 MICRON
POLISHING FILTER	68 LBS DEGASSED	110 LBS DEGASSED	110 LBS DEGASSED
TRANSFER PUMP (CENTRIGUGAL)	1/2 HP	3/4 HP	2 HP
DIMENSIONS	6' X 5' X 5'	8' X 5' X 5'	8' X 10' X 5'
NET WEIGHT	1400 LBS	2000 LBS	3200 LBS



IMPORTANT SAFETY WARNINGS



WARNING: When using this product, basic precautions should always be observed, including the following:
READ ALL SAFETY WARNINGS BEFORE USING WATER RECYCLING TREATMENT SYSTEM



HAZARD	POTENTIAL CONSEQUENCE	PREVENTION
<p data-bbox="180 268 532 327">RISK OF ELECTRIC SHOCK OR ELECTROCUTION</p> 	<p data-bbox="561 268 976 489">Serious injury or death could occur if the water recycling treatment system is not properly grounded. Your water recycling treatment system is powered by electricity and may cause electric shock or electrocution if not installed properly.</p> <p data-bbox="561 1087 976 1171">Electrical shock may occur if water recycling treatment system is not operated properly.</p> <p data-bbox="561 1325 976 1409">Serious injury or death may occur if electrical repairs are attempted by unqualified persons.</p>	<p data-bbox="995 268 1528 352">Installation of this unit, including all electrical connections, must comply with all local, state and national codes.</p> <p data-bbox="995 373 1528 541">This product must be grounded. Connect to a GFCI circuit breaker when available. If the unit should malfunction or breakdown, grounding provides a path of least resistance for electric current to reduce the risk of electric shock. Do not ground to a gas supply line.</p> <p data-bbox="995 562 1528 709">Improper connection of the equipment-grounding conductor can result in a risk of electrocution. Check with a qualified electrician or service personnel if you are in doubt as to whether the system is properly grounded.</p> <p data-bbox="995 730 1528 867">Always be certain the unit is receiving proper voltage (+/- 5% of the voltage listed on the nameplate). Before installing electrical connections, be certain the power switches are in the "OFF" position.</p> <p data-bbox="995 888 1528 909">Keep all connections dry and off the ground.</p> <p data-bbox="995 930 1528 1066">Do not touch pump, pump motor, discharge piping or water when the unit is connected to the power supply; regardless of whether the unit is operating correctly or experiencing an operation failure.</p> <p data-bbox="995 1087 1528 1171">DO NOT allow metal components of the water recycling treatment system to come in contact with live electrical components.</p> <p data-bbox="995 1192 1528 1308">Never operate the water recycling treatment system with safety guards/covers removed or damaged. Ensure all electrical covers are securely in place when unit is operating.</p> <p data-bbox="995 1329 1528 1465">Any electrical wiring or repairs performed on this water recycling treatment system should be done by Authorized Service Personnel in accordance with National and Local electrical codes.</p> <p data-bbox="995 1486 1528 1864">Before opening any electrical enclosure, always shut off the water recycling treatment system and drain the water. Disconnect the water recycling treatment system from the power source. If the power disconnect is not in sight, lock it in the open position and tag it to prevent power usage. (Never assume the water recycling treatment system is safe to work on just because it is not operating, it could restart at any time! Always disconnect from the power source.) Allow the water recycling treatment system to cool down. Service in a clean, dry, flat area.</p>



IMPORTANT SAFETY WARNINGS

READ ALL SAFETY WARNINGS BEFORE USING WATER RECYCLING TREATMENT SYSTEM

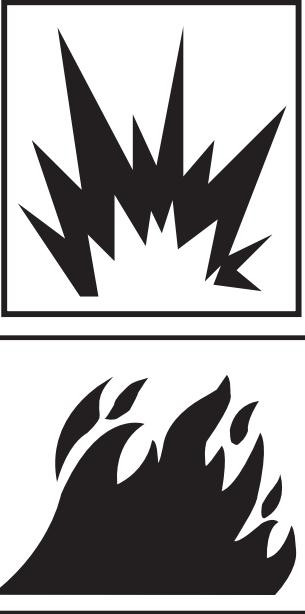
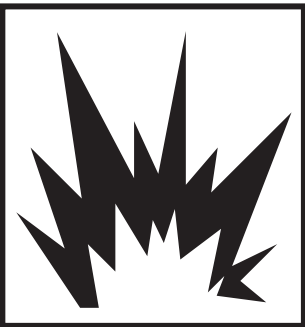

HAZARD	POTENTIAL CONSEQUENCE	PREVENTION
<p>RISK OF EXPLOSION OR FIRE</p> 	<p>Serious injury or death could occur from an explosion or fire caused by a system electric spark.</p>	<p>This unit must be placed in an area that is well ventilated, free of flammable vapors, combustible dust, gases or other combustible materials.</p>
<p>RISK OF BURSTING</p> 	<p>Serious injury or death could occur from bursting caused by excessive pressure in the system.</p> <p>Serious injury may occur if attempting to start the water recycling treatment system when the pump is frozen.</p>	<p>Do not mistreat the pressure gauges on the system. Pressure gauges will malfunction if they are subjected to excessive pressure, vibration, pulsation or temperature or if they are placed in an environment which causes corrosion of parts. Incorrect readings on a pressure gauge could mislead the operator and place him in a dangerous working condition.</p> <p>Do not use a booster pump or any type of additional pumping system. Pressurizing the suction of the pump may cause the pump body to explode.</p> <p>Do not use this water recycling treatment system to pump flammable material! An explosion could occur from a gas vapor buildup inside the system.</p> <p>In freezing temperatures, the unit must always be warm enough to ensure there is no ice formation in the pump. Do not start the water recycling treatment system if it has been in a freezing environment without first allowing the pump to thaw.</p>
<p>RISK OF BURNS</p> 	<p>Serious injury may occur from touching the electrical motor. This area can remain hot for some time after the water recycling treatment system is shutdown.</p>	<p>Never allow any part of your body to contact the electrical motor until cooled.</p>

WATER RECYCLING TREATMENT SYSTEM FLOW CHART

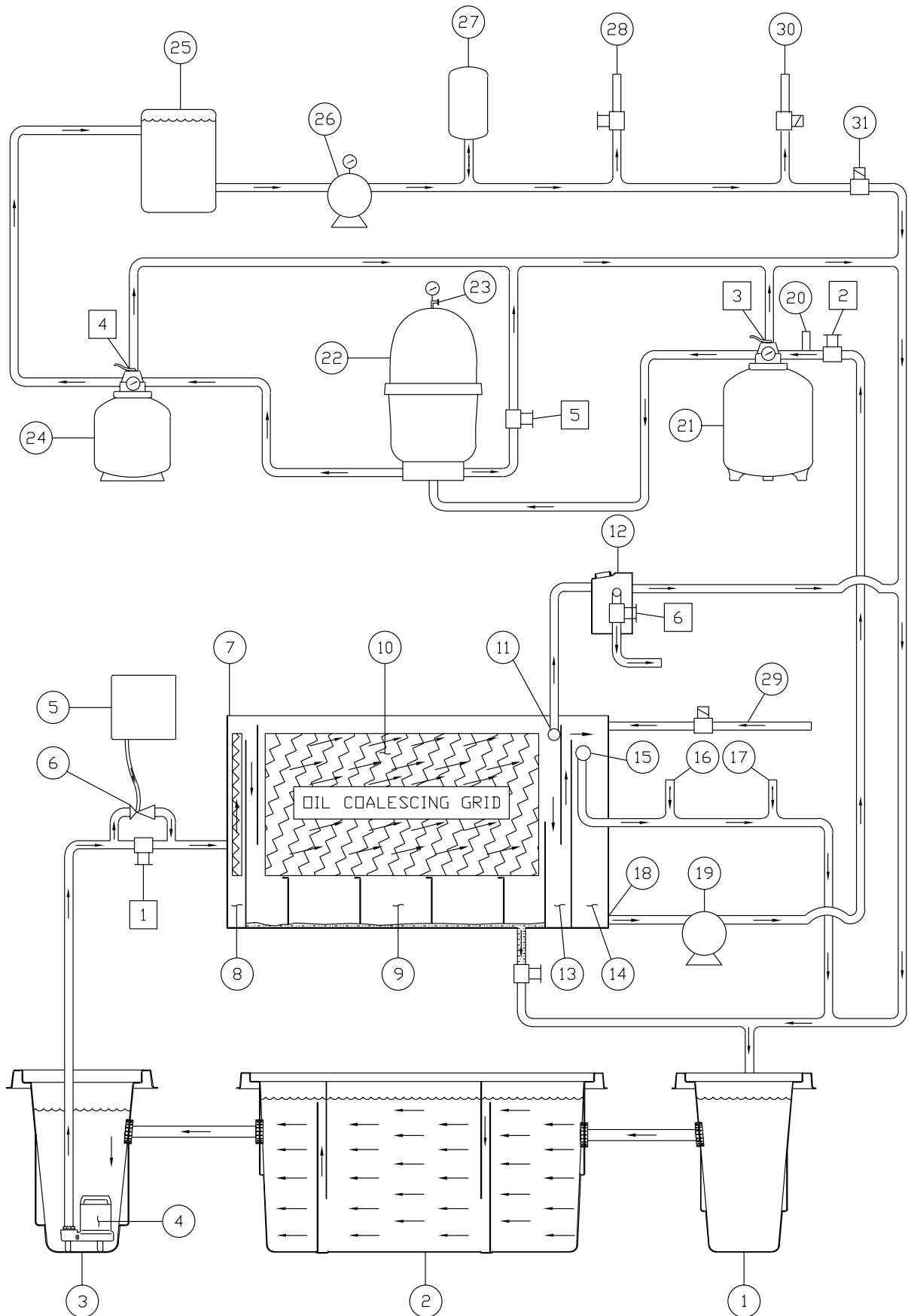

WLP-0001-112098-JJ

WATER RECYCLING TREATMENT SYSTEM FLOW CHART

As pressure washers are being operated, used water flows into the **Wash Water Catch Pit (1)**. From there, it moves to the **3-Stage Collection Pit (2)**. Heavier debris will fall to the bottom of the tank where it is trapped by a weir which is designed to stop heavy debris, while still allowing the remaining water to move into the **Sump Pit (3)**. The **Sump Pump (4)** draws water from the **Sump Pit (3)** and brings it through the Water Inlet Flow Control Valve 1. This adjustable valve is used to regulate the amount of water flow entering the water recycling treatment system. The **Ozone Generator (5)** creates ozone which the **Ozone Injector (6)** will put into the water before it enters the **Oil/Water/Solid Separator (7)**.

1. Ozone is used to kill bacteria approximately 3,000 times faster than chlorine.
2. Ozone is generated by oxygen molecules passing through a corona discharge ozone generator. This is an electric charge which causes the oxygen atoms to become ozone molecules. Since ozone molecules are extremely unstable, they only retain their structure for a very short time. For this reason, ozone cannot be stored, but instead must be continually produced by the **Ozone Generator (5)**.

The **Oil/Water/Solid Separator (7)** is made up of several sections which are separated by weirs. The ozone and water enter the first section at the bottom of the **Ozone Contact Tank (8)** and move up through the vertical coalescing grids. These grids force the ozone molecules to continue mixing with the water molecules, enabling the ozone to kill the bacteria and contaminants in the water. An overflow drain is positioned near the top of the **Ozone Contact Tank (8)** to send excess water back to the **Sump Pit (3)**. This prevents water from moving too quickly over the 1st weir, under the 2nd weir and into the bottom of the **Separator Tank (9)** which is composed of a horizontal **Oil Coalescing Grid (10)**.

1. The oil molecules in the water adhere to the **Oil Coalescing Grid (10)**. When enough oil molecules attach to each other, the oil droplets float to the surface. The **Oil Skimmer (11)** is positioned near the top of the **Separator Tank (9)** which allows the thin layer of surface oil and water to drain into the **Waste Oil Decanter (12)**. Since oil is lighter than water, the oil floats to the top and is released from the **Waste Oil Decanter (12)** when the Oil Release Valve 6 is opened. Excess water is returned to the **Wash Water Catch Pit (1)**.
2. Heavier debris will fall to the bottom of the **Separator Tank (9)** where it is trapped by a 3rd weir. This weir is only half the height of the other weirs. It is constructed to stop the debris, while still allowing the oil-free, debris-free water to move over the 3rd weir.

The water then travels under the 4th weir and into the **Water Level Control Tank (13)**. This very small section has a 5th weir positioned to control the level of water in the previous **Separator Tank (9)** tank. The top of the 5th weir is as high as the water level in the **Separator Tank (9)** tank can get. The water moves over this final 5th weir and into the **Holding Tank (14)**. From there the water moves out through one of two drains:

1. **Overflow Drain (15)**: Positioned at the top of the **Holding Tank (14)**. Excess water moves out of this drain and must go past the **Sensor Probes (16 & 17)** before being returned to the pit. (See "pH & ORP Control System" pg. 20 for details.)
2. **Holding Tank Outlet (18)**: This drain is positioned at the bottom of the **Holding Tank (14)** allowing the water to flow to the **Filter Pump (19)**.

The **Filter Pump (19)** sends the water to the Filter Control Valve 2 which regulates the amount of water going into the filtering system. A **Flow Meter (20)** is positioned just ahead of the **Multi-Media Filter (21)** to monitor flow. (Flow should be set at no more than the rating of the machine.) The Multi-Media Filter Valve 3 has six settings, with only two being utilized: Filter and Backwash. When in the "Filter" position, water flows into the **Multi-Media Filter (21)** from the top and passes through several layers of filtering product as it moves toward the bottom. By the time the water reaches the bottom of the filter tank, the contaminants have been filtered down to approximately 30 microns. Laterals are positioned at the bottom of the filter tank which absorb the filtered water and move it up through the center and out the top of the tank. From there, the water flows into the bottom of the **Cartridge Filter (22)**. A Cartridge Filter Drain Valve 5 is located at the bottom of the **Cartridge Filter (22)** for filter cleaning purposes. This valve should be closed during the water recycling treatment operation. On initial start-up, the **Air Bleed Valve (23)** must be opened to let air escape while the **Cartridge Filter (22)** fills with water. Once full, and the **Air Bleed Valve (23)** is closed, the water passes through the Reemay® Polyester Fiber filter which reduces the contaminants down to 20 microns. The water moves out of the **Cartridge Filter (22)** and into the Polishing Filter Valve 4. This valve has 5 settings, two of which are utilized: Filter and Backwash. When in the "Filter" position, water flows into the **Polishing Filter (24)** from the top and passes through the activated carbon or filtering agent. As it moves toward the bottom, the activated carbon or filtering agent absorbs odor and contaminants while "polishing" the water. Laterals are positioned at the bottom of the tank which absorb the water and move it up through the center and out the top of the tank. From there, the water moves to the **Product Tank (25)** where the recycled water is held until usage is required. When needed, water is pulled from the **Product Tank (25)** by the **Transfer Pump (26)** and moved into the **Pressure Tank (27)**. This tank holds water at 30-50 PSI/2.0-3.5 Bar. Water moves directly from this tank to the water discharge outlets upon demand.

If water is needed for washing, water is sent to the **Outlet to Pressure Washer (28)**.

If the **Wash Water Catch Pit (1)** water level is low, water is added through the **Fresh Water Makeup (29)**.

If the **Wash Water Catch Pit (1)** water level is too high, water is sent to the **Rain Water Overflow (30)**.

If the recycle timer turns on, water is sent through the **Recycled Wash Water (31)** to the **Wash Water Catch Pit (1)**.

PLATFORM VIEW FOR WLP-08

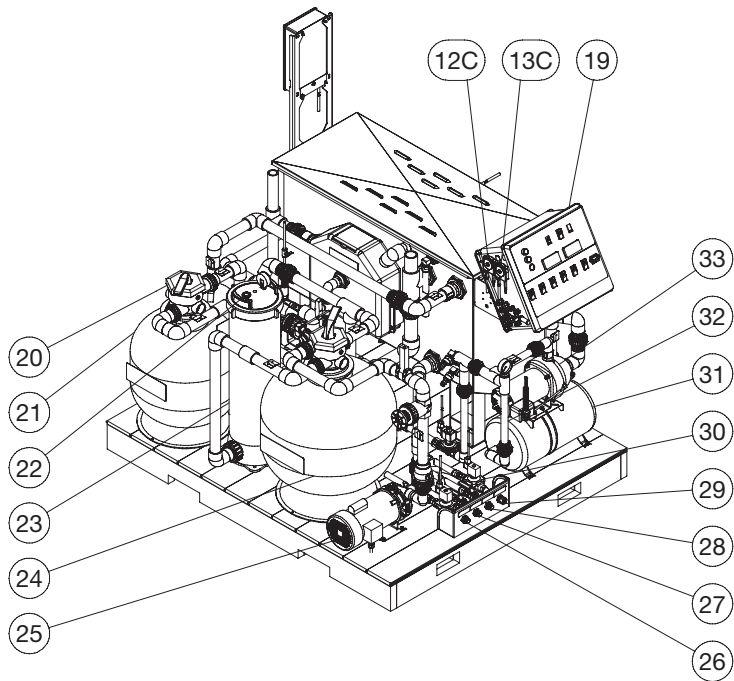
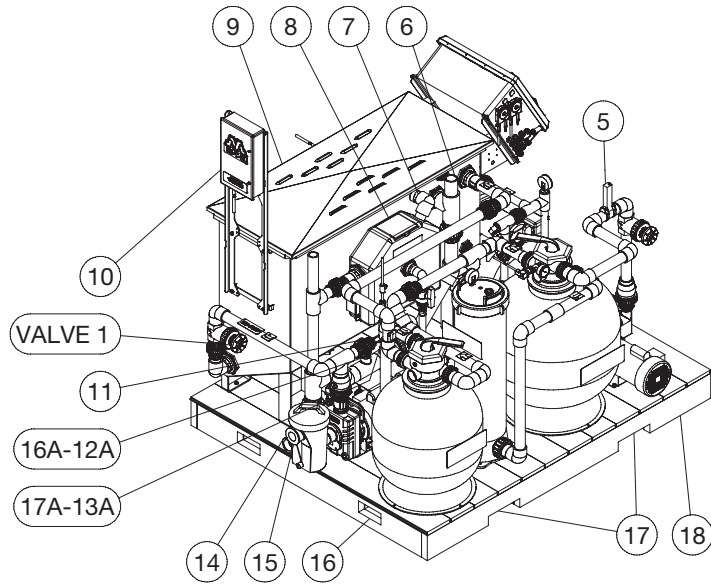

WLP-08-OM10 FEATURES 1 030422 ATL

-Water Inlet Flow Control **Valve 1**

-Filter Control **Valve 2**

-Multi-Media Filter **Valve 3**

-Oil Release **Valve 4**

-Cartridge Filter Drain **Valve 5**

- Polishing Filter **Valve 6**

ITEM #	DESCRIPTION	
5	FLOW METER	14
6	OVERFLOW DRAIN	15
7	OIL SKIMMER	16
8	WASTE OIL DECANTER	17
9	SEPARATOR TANK LID	18
10	OZONE GENERATOR	19
11	OZONE INJECTOR	20
12A	pH SENSOR PROBE (NOT SHOWN)	21
12B	pH METER	22
12C	pH PUMP	23
12D	pH CHEMICAL INJECTOR (NOT SHOWN)	24
13A	ORP SENSOR PROBE (NOT SHOWN)	25
13B	ORP METER	26
13C	ORP PUMP	27
13D	ORP CHEMICAL INJECTOR (NOT SHOWN)	28
		29
		30
		31
		32
		33

AERIAL VIEW FOR WLP-08

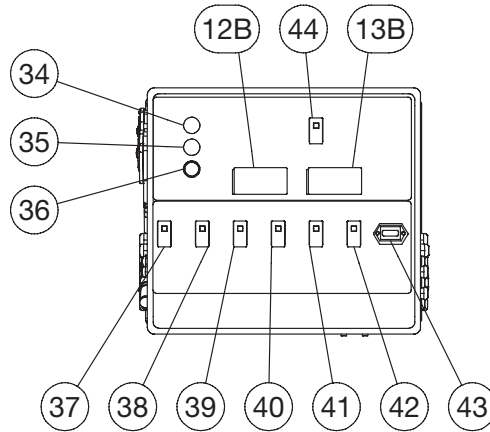
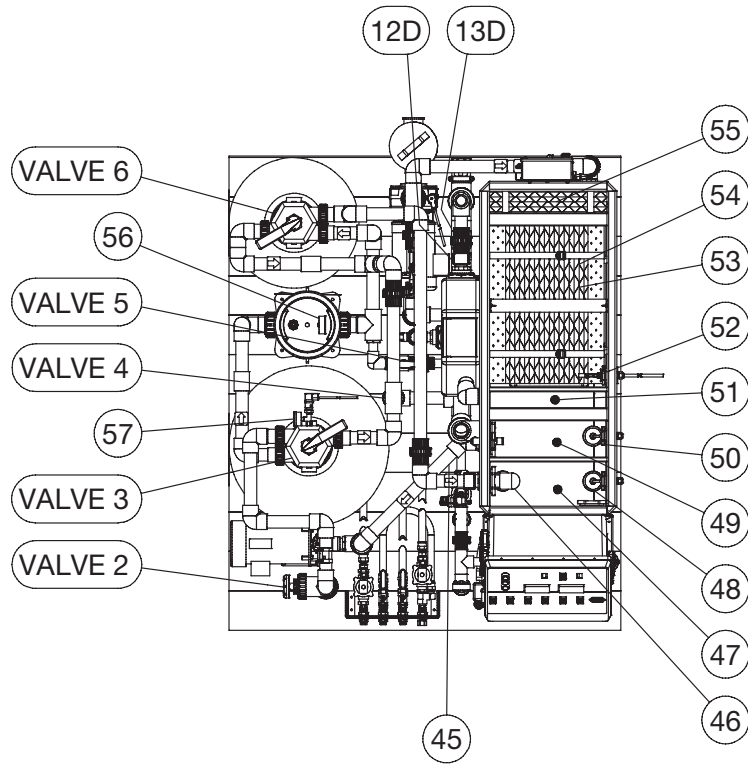

- | | | | |
|----|-------------------------------------|----|---------------------------|
| 29 | FRESH WATER INLET | 44 | OZONE SWITCH |
| 30 | RECYCLED WASH WATER | 45 | HOLDING TANK OUTLET |
| 31 | PRESSURE TANK | 46 | TRANSFER PUMP FLOAT |
| 32 | GAUGE: TRANSFER PUMP | 47 | PRODUCT TANK |
| 33 | TRANSFER PUMP | 48 | HIGH FILTER PUMP FLOAT |
| 34 | POWER INDICATOR LIGHT | 49 | HOLDING TANK |
| 35 | INDICATOR LIGHT : BACKWASH REQUIRED | 50 | LOW FILTER PUMP FLOAT |
| 36 | BACKWASH SWITCH | 51 | WATER LEVEL CONTROL TANK |
| 37 | SUMP PUMP SWITCH | 52 | LEVEL LIMIT SWITCH |
| 38 | FILTER PUMP SWITCH | 53 | OIL COALESCING GRID |
| 39 | TRANSFER PUMP SWITCH | 54 | SEPARATOR TANK |
| 40 | pH/ORP METERS SWITCH | 55 | OZONE CONTACT TANK |
| 41 | pH PUMP SWITCH | 56 | GAUGE: CARTRIDGE FILTER |
| 42 | ORP PUMP SWITCH | 57 | GAUGE: MULTI-MEDIA FILTER |
| 43 | HOUR METER | | |

PLATFORM VIEW FOR WLP-20

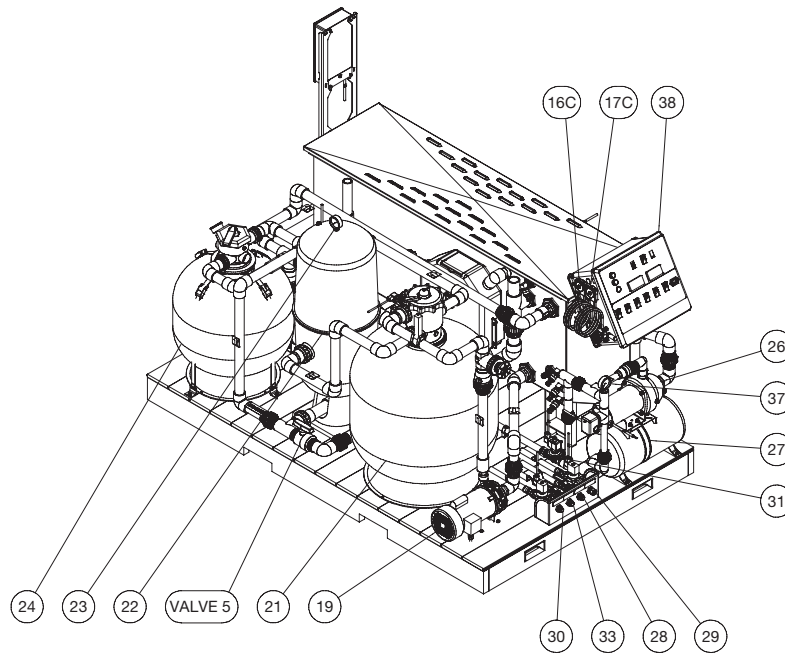
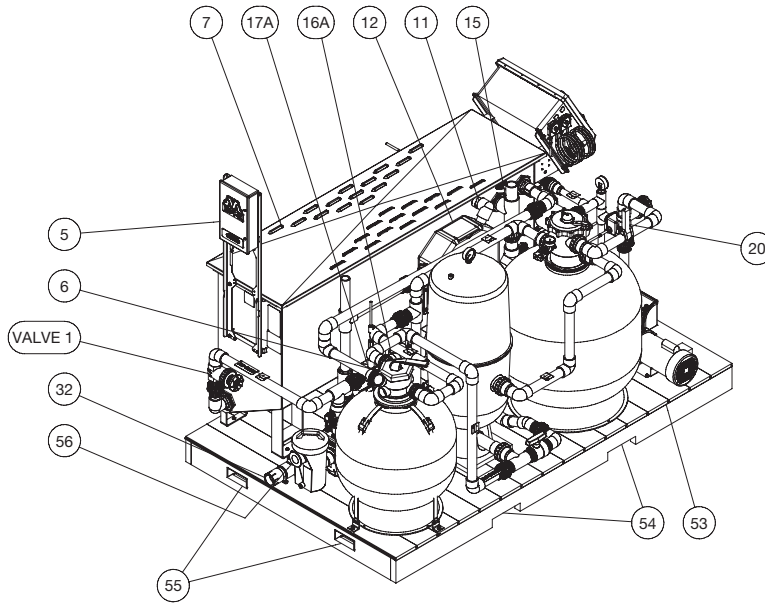

WLP-20-0M10 FEATURES 1 032522 ATL

-Oil Release **Valve 1**

-Polishing Filter **Valve 2**

-Multi-Media Filter **Valve 3**

-Cartridge Filter Drain **Valve 4**

-Filter Control **Valve 5**

-Water Inlet Flow Control **Valve 6**

ITEM #	DESCRIPTION	
5	OZONE GENERATOR	17A ORP SENSOR PROBE
6	OZONE INJECTOR	17B ORP METER
7	SEPARATOR TANK LID	17C ORP PUMP
8	OZONE CONTACT TANK	17E ORP CHEMICAL INJECTOR
9	SEPARATOR TANK	18 HOLDING TANK OUTLET
10	OIL COALESCING GRID	19 FILTR PUMP
11	OIL SKIMMER	20 FLOW METER
12	WASTE OIL DECANTER	21 MULTI-MEDIA FILTER
13	WATER LEVEL CONTROL TANK	22 CARTRIDGE FILTER
14	HOLDING TANK	23 AIR BLEED VALVE
15	OVERFLOW DRAIN	24 POLISHING FILTER
16A	PH SENSOR PROBE	25 PRODUCT TANK
16B	PH METER	26 TRANSFER PUMP
16C	PH PUMP	27 PRESSURE TANK
16E	PH CHEMICAL INJECTOR	28 OUTLET TO PRESSURE WASHER

AERIAL VIEW FOR WLP-20

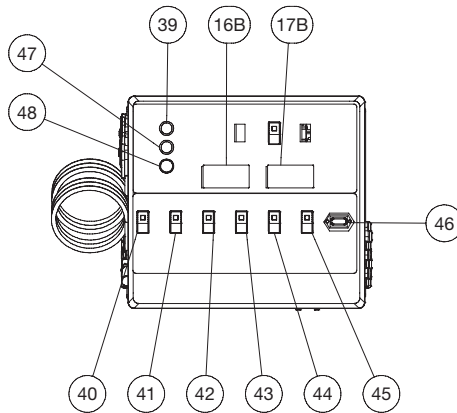
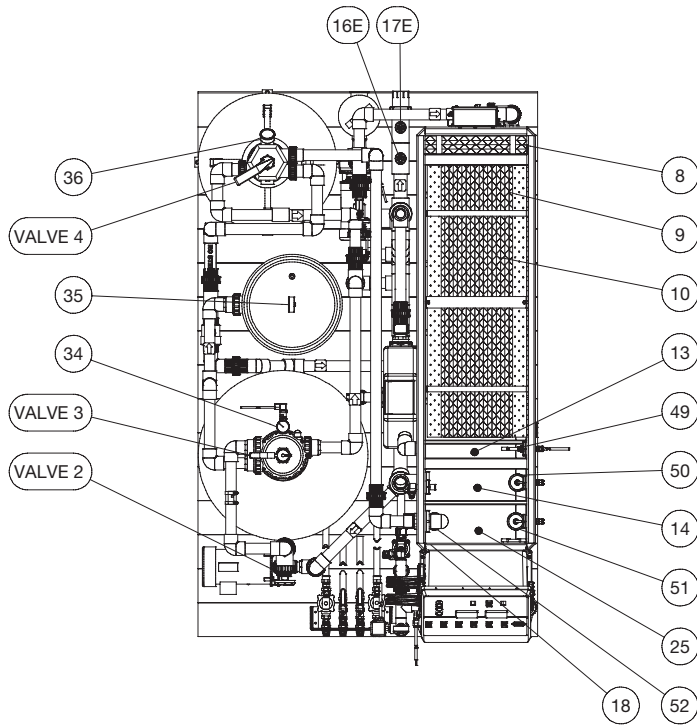

- | | | | |
|----|---------------------------|----|------------------------------------|
| 29 | FRESH WATER INLET | 43 | PH/ORP METERS SWITCH |
| 30 | RAIN WATER OVERFLOW | 44 | PH PUMP SWITCH |
| 31 | RECYCLED WASH WATER | 45 | ORP PUMP SWITCH |
| 32 | OUTLET RETURN TO PIT | 46 | HOUR METER |
| 33 | RINSE WATER OUTLET | 47 | INDICATOR LIGHT: BACKWASH REQUIRED |
| 34 | GAUGE: MULTI-MEDIA FILTER | 48 | BACKWASH SWITCH |
| 35 | GAUGE: CARTRIDGE FILTER | 49 | LEVEL LIMIT SWITCH |
| 36 | GAUGE: POLISHING FILTER | 50 | LOW FILTER PUMP FLOAT |
| 37 | GAUGE: TRANSFER PUMP | 51 | HIGH FILTER PUMP FLOAT |
| 38 | CONTROL PANEL | 52 | TRANSFER PUMP FLOAT |
| 39 | POWER INDICATOR LIGHT | 53 | SKID |
| 40 | SUMP PUMP SWITCH | 54 | SIDE FOR LIFT HOLES |
| 41 | FILTER PUMP SWITCH | 55 | END FORK LIFT HOLES |
| 42 | TRANSFER PUMP SWITCH | 56 | INLET FROM SUMP PUMP |

PLATFORM VIEW FOR WLP-40

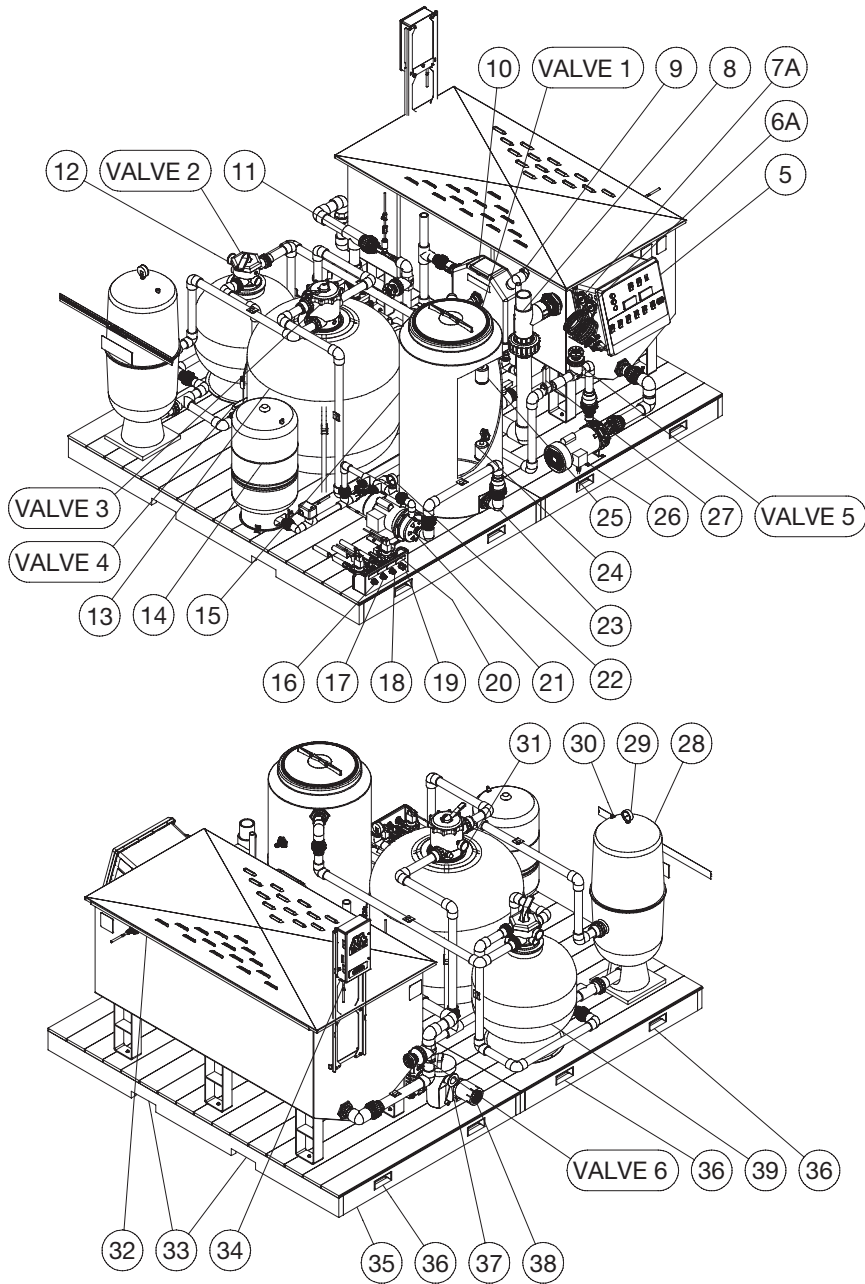

WLP-40-0M10 FEATURES 1 030422 ATL

-Oil Release **Valve 1**

-Polishing Filter **Valve 2**

-Multi-Media Filter **Valve 3**

-Cartridge Filter Drain **Valve 4**

-Filter Control **Valve 5**

-Water Inlet Flow Control **Valve 6**

- | | | | |
|----|-------------------------|----|---------------------------|
| 5 | CONTROL PANEL | 14 | PRESSURE TANK |
| 6A | ORP PUMP | 15 | PRODUCT TANK |
| 6B | ORP METER | 16 | RAIN WATER OVERFLOW |
| 6C | ORP SENSOR PROBE | 17 | RINSE WATER OUTLET |
| 6D | ORP CHEMICAL INJECTOR | 18 | OUTLET TO PRESSURE WASHER |
| 7A | pH PUMP | 19 | FRESH WATER INLET |
| 7B | pH METER | 20 | RECYCLED WASH WATER |
| 7C | pH SENSOR PROBE | 21 | TRANSFER PUMP |
| 7D | pH CHEMICAL INJECTOR | 22 | GAUGE: TRANSFER PUMP |
| 8 | OVERFLOW DRAIN | 23 | HOLDING TANK OUTLET |
| 9 | OIL SKIMMER | 24 | TRANSFER PUMP FLOAT |
| 10 | WASTE OIL DECANTER | 25 | HIGH FILTER PUMP FLOAT |
| 11 | OZONE INJECTOR | 26 | FILTER PUMP |
| 12 | GAUGE: POLISHING FILTER | 27 | FLOW METER |
| 13 | MULTI-MEDIA FILTER | 28 | CARTRIDGE FILTER |

AERIAL VIEW FOR WLP-40

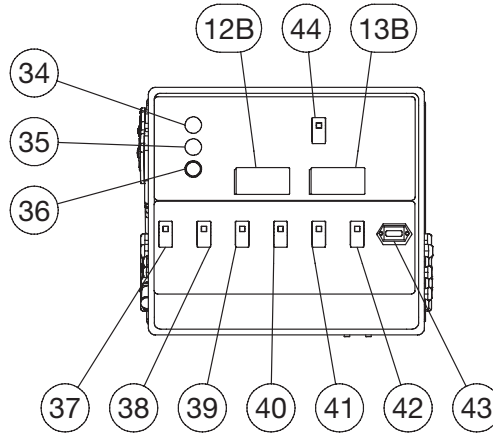
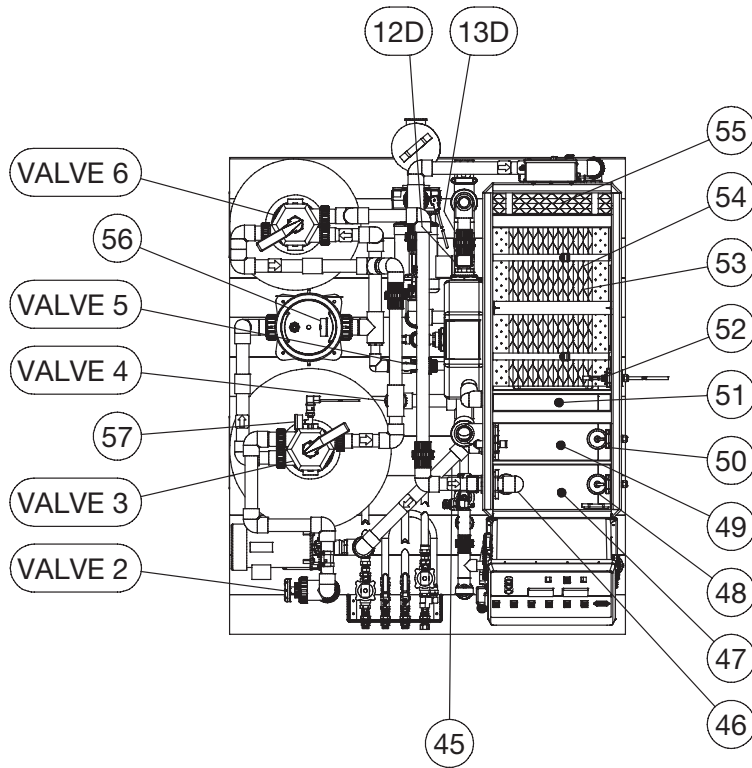

WLP-08-0M10 FEATURES 2 030422 ATL

- | | | | |
|----|------------------------------------|----|----------------------------|
| 29 | GAUGE: CARTRIDGE FILTER | 44 | FILTER PUMP SWITCH |
| 30 | AIR BLEED VALVE | 45 | TRANSFER PUMP SWITCH |
| 31 | GAUGE: MULTI-MEDIA FILTER | 46 | pH/ORP METERS SWITCH |
| 32 | SEPARATOR TANK LID | 47 | pH PUMP SWITCH |
| 33 | END FORK LIFT HOLES | 48 | ORP PUMP SWITCH |
| 34 | OZONE GENERATOR | 49 | HOUR METER |
| 35 | SKID | 50 | OZONE PUMP SWITCH (ON/OFF) |
| 36 | SIDE FORK LIFT HOLES | 51 | LOW FILTER PUMP FLOAT |
| 37 | INLET FROM SUMP PUMP | 52 | HOLDING TANK |
| 38 | OUTLET RETURN TO PIT | 53 | WATER LEVEL CONTROL TANK |
| 39 | POLISHING FILTER | 54 | LEVEL LIMIT SWITCH |
| 40 | POWER INDICATOR LIGHT | 55 | OIL COALESCING GRID |
| 41 | INDICATOR LIGHT: BACKWASH REQUIRED | 56 | SEPARATOR TANK |
| 42 | BACKWASH SWITCH | 57 | OZONE CONTACT TANK |
| 43 | SUMP PUMP SWITCH | | |

PREPARATION

ATTIRE:

1. Proper attire is essential to your safety. It is advised to utilize whatever means necessary to protect eyes, ears, and skin.

INSTALLATION:

1. A Collection Pit System must already be an established structure before installing the WLP-Series water recycling treatment system. A well designed pit system is critical for the proper operation of the recycle system. Consult your dealer for installation requirements.
2. Place the water recycling treatment system platform on a hard, level surface in an area free of flammable vapors, combustible dust, gases or other combustible materials. Place a level on the **Oil/Water/Solids Separator (7)** to ensure it is level. Shim the **Skid (53)** if necessary.

WLP-40 ONLY:

- a. Line up the two skids so the two PVC lines from each skid are flush with each other.
- b. Connect the PVC lines by tightening the unions.
- c. Connect the two floats from the **Product Tank (25)** to the **Control Panel (38)**.
- d. Connect the power cord from the **Control Panel (38)** to the **Transfer Pump (26)**.
- e. Solenoid actuators will need to be attached to the valve assemblies behind the **Fresh Water Inlet (29)** and the **Rain Water Overflow (30)**. Be certain the numbers on the solenoid and solenoid actuators match.

PREPARATION

3. Set the unit so you have access to the filters and **Control Panel (38)**.
4. Do not place unit in an area:
 - a. with insufficient ventilation.
 - b. where environmental hazards (i.e. rain and snow) can come in contact with the water recycling treatment system.
 - c. in a freezing environment.
5. The water recycling treatment system is shipped with union connections loosened to protect the unit from shipping damage. Tighten all union connections at this time.
6. Hook up the **Inlet From Sump Pump (56)** and **Outlet Return To Pit (32)** plumbing. Use schedule 80 PVC slip connections.
 - a. Install the **Sump Pump (4)** in the **Sump Pit (3)** as shown below.
 - b. Install plumbing from **Sump Pump (4)** using minimum connection sizes as listed:

WLP-8 / WLP-20	WLP-40
1-1/2"	2"
 - c. Install a check valve near the outlet plumbing of the **Sump Pit (3)**.
 - d. Install the return plumbing using minimum connection sizes as listed:

WLP-8	WLP-20	WLP-40
1-1/2"	2"	3"
7. Install the three floats in the **Sump Pit (3)**. Allow a 2" tether and enough room for them to move freely without interfering with the plumbing.
 - a. Float #1 Blue: Pit low level shut-off. Attach this float 10" above the **Sump Pump (4)** inlet.
 - b. Float #5 Red: Fresh water makeup. Height of this float must be adjusted to the individual pit system.
 - c. Float #6 Green: Rain water overflow. Height of this float must be adjusted to the individual pit system.

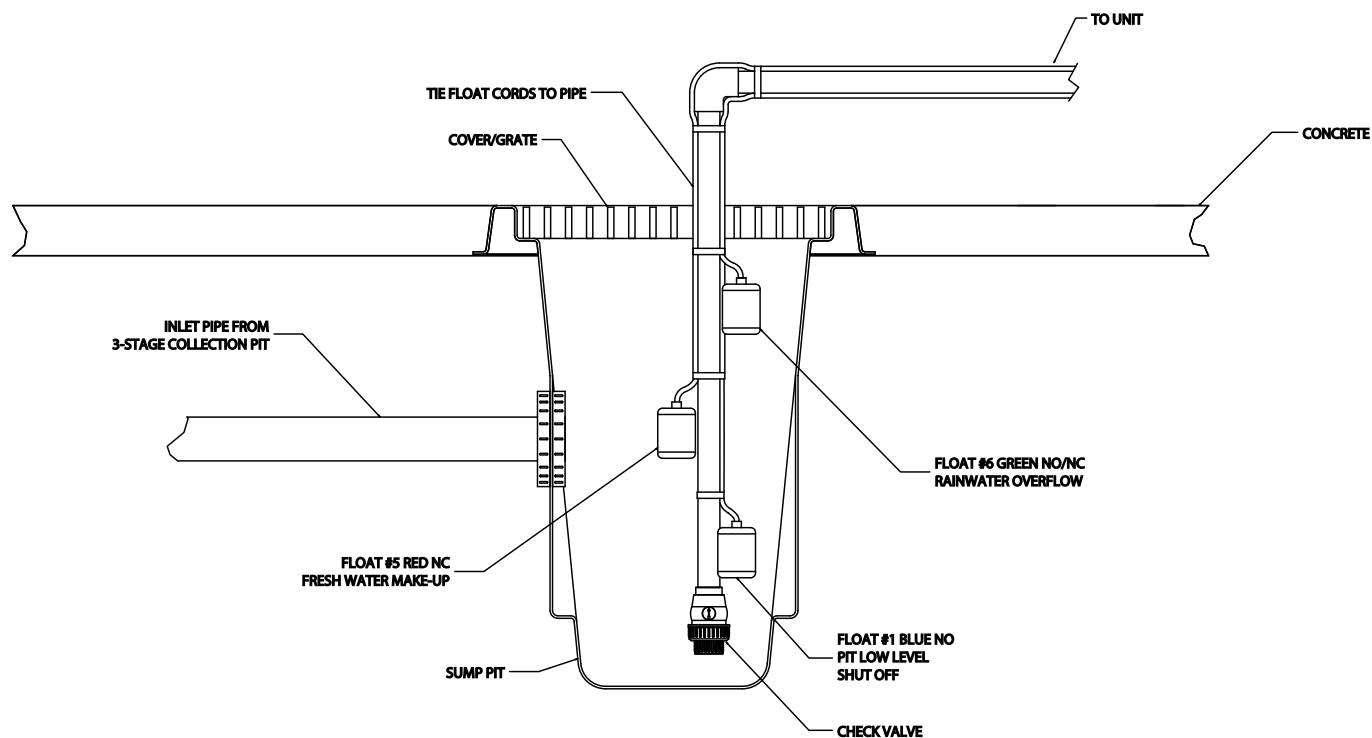

SUMP PUMP LAYOUT WLP-082902-KS

PREPARATION



WARNING

RISK OF ELECTROCUTION! TO REDUCE THE RISK OF ELECTROCUTION, KEEP ALL CONNECTIONS DRY AND OFF THE GROUND.

8. A qualified electrician must hook up the electrical system.
 - a. Verify the electrical supply at the power source is off.
 - b. Be certain all switches on the **Control Panel (38)** are in the "OFF" position.
 - c. Run water tight conduit
 1. From the **Sump Pump (4)** and Floats to the **Control Panel (38)**.
 2. From the local disconnect to the **Control Panel (38)**. The electrician will need to drill holes in the **Control Panel (38)** for the conduit.
 - d. Make connections to the terminal strips as shown below.

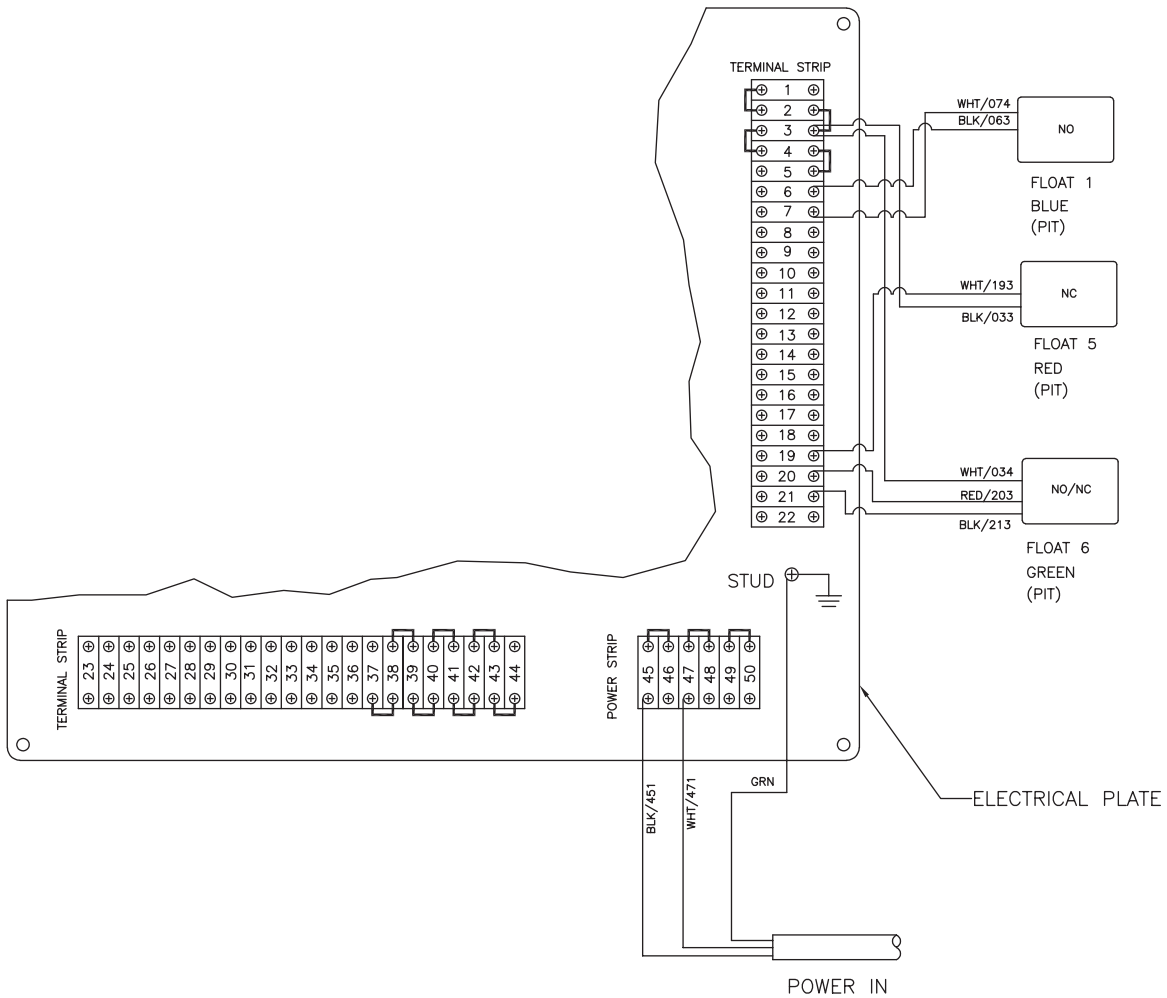

FIELD WIRING DIAGRAM WLP 8-20-30-40 230V 1PH 070218 MLK

9. Make the following hose connections:
 - a. From a pressurized water supply to the **Fresh Water Makeup (29)**.
 - b. From the **Outlet to Pressure Washer (28)** to the pressure washer.
 - c. From the **Rain Water Overflow (30)** to a sewer or drain. Do not send this water back to the **Wash Water Catch Pit (1)**!

NOTE: In most cases, you must have a permit to legally dispose recycled water.

STOP

TO ENSURE YOUR WATER RECYCLE TREATMENT SYSTEM OPERATES SAFELY AND EFFICIENTLY, COMPLETE THE PRE-OPERATION CHECKLIST BEFORE PROCEEDING.

PRE-OPERATION CHECKLIST

Before proceeding, answer all the questions on this checklist.	YES	NO
CODES:		
1. Does the electrical wiring meet all codes?		
2. Does plumbing meet all codes?		
LOCATION:		
1. Is the unit located on a hard level surface free of flammable vapors, combustible dust, gases or other combustible materials?		
2. Is the unit located in a large ventilated area?		
ELECTRICAL:		
1. Is the unit properly grounded?		
2. Does the power supply, voltage and amperage match the data plate?		
PLUMBING:		
1. Is the plumbing sized correctly?		
2. Is the check valve installed near the Sump Pump (4) ?		
3. Are all unions tightened?		
GENERAL:		
1. Have all operators using this unit read and understood this entire manual?		
2. Has the unit been installed by qualified service people who followed the instructions listed in this manual?		

IF "NO" WAS MARKED TO ANY OF THESE QUESTIONS, CORRECT THE SITUATION BEFORE OPERATING.

PREPARATION

PRESTART PROCEDURES:

1. Position the valves on the WLP water recycling treatment system in the "Start-up Mode".
 - Water Inlet Flow Control Valve 1: Turn valve one rotation short of completely closed.
 - Filter Control Valve 2: Turn valve one rotation short of completely closed.
 - Multi-Media Filter Valve 3: Turn valve to "Filter".
 - Polishing Filter Valve 4: Turn valve to "Filter".
 - Cartridge Filter Drain Valve 5: Turn valve completely closed.
 - Air Bleed Valve (23): Turn valve open.
 - Oil Release Valve 6: Turn valve completely closed.
 2. Be certain all hoses are securely connected. (See Installation #9, pg. 18.)
 3. Be certain the incoming air tube to the **Ozone Generator (5)** is not obstructed.
 4. Be certain all switches on the **Control Panel (38)** are in the "OFF" position.
 5. Turn on the power supply. The **Power Indicator Light (39)** should glow.
-

START-UP:

1. Ensure water supply from the **Freshwater Make-up (29)** is turned on and pit is filled with water.
2. Turn on the **Sump Pump Switch (40)**. Water will flow into the **Oil/Water/Solids Separator (7)**.
3. Turn on the switch located on the **Ozone Generator (5)**.
4. Flow can be increased by opening the Water Inlet Flow Control Valve 1. Fill the **Oil/Water/Solids Separator (7)**.
5. As the water fills the **Holding Tank (14)**, it will begin to flow out the **Overflow Drain (15)** at the top of the tank. At this point, flow can be adjusted with the Water Inlet Flow Control Valve 1. Maximum flow is achieved when the water level remains constant in the **Holding Tank (14)**.
6. Turn on the **Filter Pump Switch (41)**. The **Filter Pump (19)** will automatically turn off when the system is full of water.
7. As water flows to the filters, use the Filter Control Valve 2 to adjust the water flow to the unit rating maximum. Check the **Flow Meter (20)** located ahead of the **Multi-Media Filter (21)**.
8. Allow **Multi-Media Filter (21)** to fill. Once full, water will begin to flow to the **Cartridge Filter (22)**.
9. Air will release from the **Air Bleed Valve (23)** as the **Cartridge Filter (22)** fills. Close the **Air Bleed Valve (23)** when water begins to exit from it. This indicates the **Cartridge Filter (22)** is filled and water will begin flowing to the **Polishing Filter (24)**. For optimum efficiency, occasionally open the **Air Bleed Valve (23)** while the **Filter Pump (19)** is operating to relieve any air buildup.
10. Once the **Polishing Filter (24)** is full, water will begin flowing to the **Product Tank (25)**.
11. When the **Product Tank (25)** is full and the **Filter Pump (19)** turns off, prime the **Transfer Pump (26)** by opening the **Outlet to Pressure Washer (28)** valve until water exits.
12. Turn on the **Transfer Pump Switch (42)** to allow water to flow into the **Pressure Tank (27)**.
13. Water is now completely cycled in the system.

PREPARATION

pH AND ORP CONTROL SYSTEM:

Proper pH and ORP levels must be maintained in the pit to prevent growth of bacteria, algae, odors, etc. Water must be chemically balanced to effectively recycle. The **Ozone Generator (5)** will destroy most bacteria, but if the water becomes chemically unbalanced, you may need to add chlorine to regain control. The effectiveness of chlorine in the water depends on the pH level.

-The optimum pH level to safely add chlorine is 6.0. At this level, the chlorine is approximately 95% effective.

-As the pH level rises to 7.0, the effective rate drops to approximately 70%.

-At a pH level of 8.0 and above, the chlorine is essentially ineffective.

As excess water flows from the **Overflow Drain (15)**, it moves past the **pH and ORP Sensor Probes (16A & 17A)** before returning to the **Waste Water Catch Pit (1)**. The **Sensor Probes (16A & 17A)** analyze the pH and ORP levels in the water.

- a. **pH Sensor Probe (16A)**. This probe analyzes the pH (acidity & alkalinity) in the water. If the water is too acidic (low pH) the acid will breakdown the iron present in the water to a liquid form, thus causing rusty looking water in the system. If the water is too alkaline (high pH) the bacteria killing potential of the ORP agent will be drastically lowered.

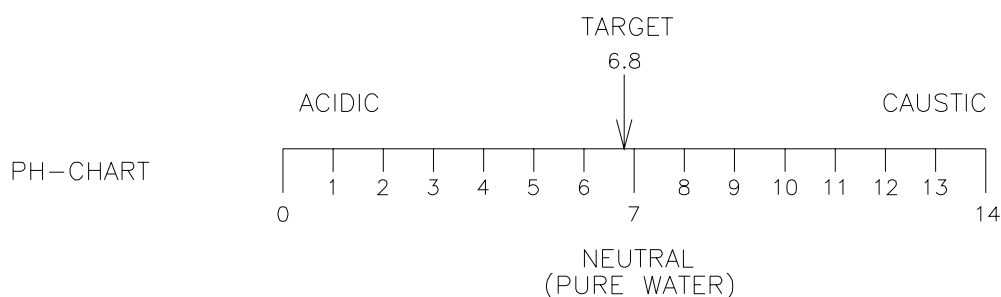

WLP-0008-112098-JJ

- b. **ORP Sensor Probe (17A)**. This probe analyzes the Oxidation Reduction Potential (ORP). This reading states amount of bacteria killing agent in the water.

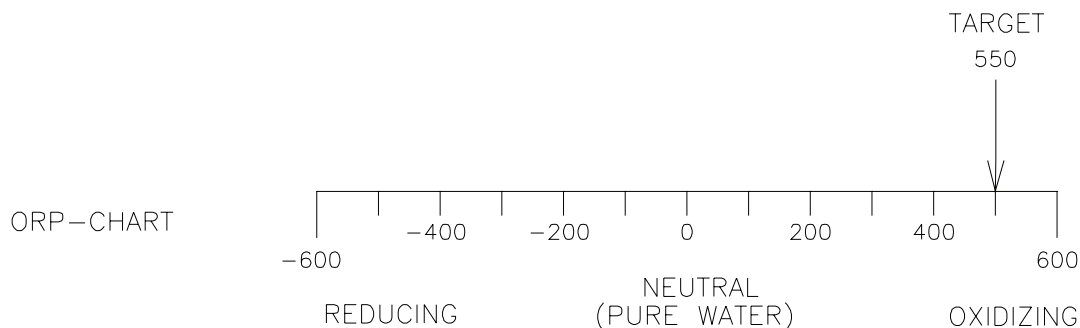

WLP-0009-112098-JJ

The probes analyze the pH and ORP levels of the water and display the readings in the digital **pH and ORP Meters (16B & 17B)**.

INSTALLATION

INSTALLATION OF PH AND ORP PROBES:

CAUTION

RISK OF PROBE DAMAGE!

- DO NOT ALLOW PROBES TO BE EXPOSED TO AIR. ONCE PROBES ARE IN PLACE, TURN WATER ON IMMEDIATELY.
- HANDLE PROBES CAREFULLY AS THEY ARE MADE OF GLASS.
- DO NOT ALLOW PROBES TO BE EXPOSED TO FREEZING ENVIRONMENTS. KEEP THE ORIGINAL CONTAINERS IN WHICH THE PROBES WERE SHIPPED. THEY WILL BE NEEDED FOR PROBE STORAGE DURING WINTERIZING.

1. Turn off the **Sump Pump Switch (40)** and ensure no water is being discharged.
2. Locate the probe grips at the **Chemical Injectors (16E & 17E)** and unscrew the nut from one of the grips.
3. Remove one of the probes (pH or ORP) from its storage container. (Be certain to save the container for probe storage during winterizing.)
4. Carefully slide the probe grip nut over the glass probe.
5. Gently push the probe through the probe grip approximately 2 inches and tighten the nut onto the probe grip.
6. Repeat process for the remaining probe.
7. Turn on the **Sump Pump Switch (40)** and the **pH/ORP Meters Switch (43)**.

pH SENSOR PROBE

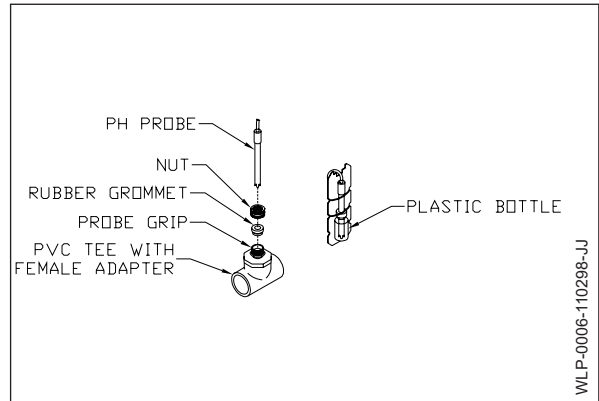

ORP SENSOR PROBE

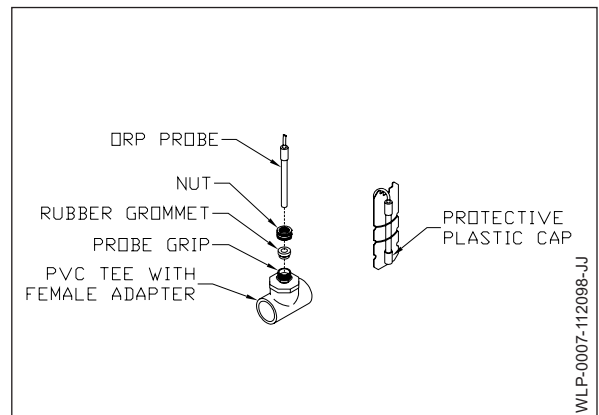

INSTALLATION

PH CONTROLLER PROGRAMMING

pH controller will come programmed and on measure mode with the following parameters set.

Measure Mode: pH

- **Temperature Compensation:** 03 MAN (No use of a temperature probe, manually can adjust temperature but this is normally is not required as long as temperature is in the 60°F-80° it has a small effect on pH reading.)
- **Manual temperature set at 70°F.**
- **7.00 Buffer and 4.01 Buffer:** Controller is calibrated on STAND using a 7 pH buffer solution or calibrator, then a 4.00 buffer calibrator for SLOPE. This will never need to be changed.
- **pH relay 1 selected for HI1:** Relay 1 will be closed if the probe reads HIGH over the set point (+ 1/2) the hysteresis. This relay will turn on the chemical pump, low pH chemical to be used to lower pH. Relay 1 can be changed to LOW1 to work in the opposite direction; if probe reads below set point the chemical pump will turn on to add high pH chemical.
- **Set point 1 is 7.00:** pH point at which (+,-) half the hysteresis, the relays will close to turn on chemical pump.
- **Hysteresis is at 0.20:** The range around the set point that the relays will turn on and off. At a set point of 7.00, the relay will close between 7.10 and 6.90.
- Set point 2, Relay 2 and Hysteresis 2 is not used for pH controller.

For ORP controllers will come programmed and on measure mode with the following parameters set.

ORP CONTROLLER PROGRAMMING:

ORP controllers will come programmed and on measure mode with the following parameters set.

MEASURE MODE: ORP RMV

- **Temperature Compensation:** 03 MAN (No use of a temperature probe) does not affect ORP reading.
- **Manual temperature set at 70°F.**
- **7.00 Buffer and 4.01 Buffer:** Controller is calibrated on STAND using a 7 pH buffer solution or calibrator, then a 4.00 buffer calibrator for SLOPE. This will never need to be changed.
- **Relay 1:** Set for ORP RMV
- **ORP relay 1 selected for LOW1:** Relay 1 will be closed if the probe reads LOW under the set point (- 1/2) the hysteresis. This relay will turn on the ORP chemical pump.
- **Set point 1 is 350rmv:** ORP point at which (+,-) half the hysteresis, the relays will close to turn on chemical pump.
- **Hysteresis is at P10.0:** The range around the set point that the relays will turn on and off. At a set point of 350mv, the relay will close between 345mv and 355mv.
- Relay 2 is not used for ORP controller.

FRONT PANEL

The front panel consists of a 4-digit LCD display and 4 keys.

1. [MODE] key:

- 1a. In the Measure mode, this key will switch the display in sequence from pH, Temperature, ORP absolute mV, ORP relative mV and back to pH again.
- 1b. In the Calibration/Setting mode, pressing this key for three seconds will move you back to the previous parameter in the case when recalibration / resetting is required.

2. [UP] key:

- 2a. In the Calibration mode, pressing this key will show the next possible option. In the Setting mode, pressing this key will show the next possible option and increases the numeral increment.
- 2b. In the Measure mode, pressing this key and [ENTER] key at the same time, the unit will enter the Calibration mode.

3. [DOWN] key:

- 3a. In the Calibration mode, pressing this key will show the next possible option. In the Setting mode, pressing this key will show the next possible option and decreases the numeral increment.

- 3b. In the Measure mode, pressing this key and [ENTER] key at the same time, the unit will enter the Setting mode.

4. [ENTER] key:

In any mode where the user can change the settings, pressing this key will save the new settings. If no change has been made then pressing this key will just move the user to the next setting.

INSTALLATION

LCD SCREEN

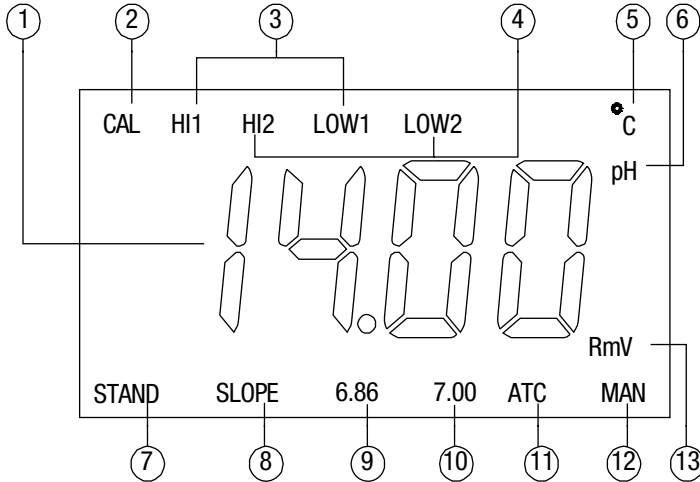

1. Major LCD display.
2. **CAL** – This icon will be displayed if the meter is in the Calibration/Setting mode.
3. **HI1 & LOW1** – These icons, when displayed, indicate relay action and relay number.
4. **HI2 & LOW2** – These icons, when displayed, indicate relay action and relay number.
5. **°C** – Temperature and unit display.
6. **pH** – Unit indicator.
7. **STAND** – This icon will blink before Buffer 1 calibration. The icon will stay on while Buffer 1 is being calibrated.
8. **SLOPE** – This icon will blink before Buffer 2 calibration. The icon will stay on while Buffer 2 is being calibrated.
9. **6.86** – The 6.86 buffer group: 6.86, 4.00, 9.18.
10. **7.00** – The 7.00 buffer group: 7.00, 4.01, 10.01.
11. **ATC** – This icon will be displayed when a temperature probe is connected.
12. **MAN** – This icon will be displayed when a temperature probe is not connected.
13. **RmV** – Unit indicator.

MEASURE MODE

Turning on the unit will always display the **Measure mode**. This instrument is designed to provide 4 distinct measurements:

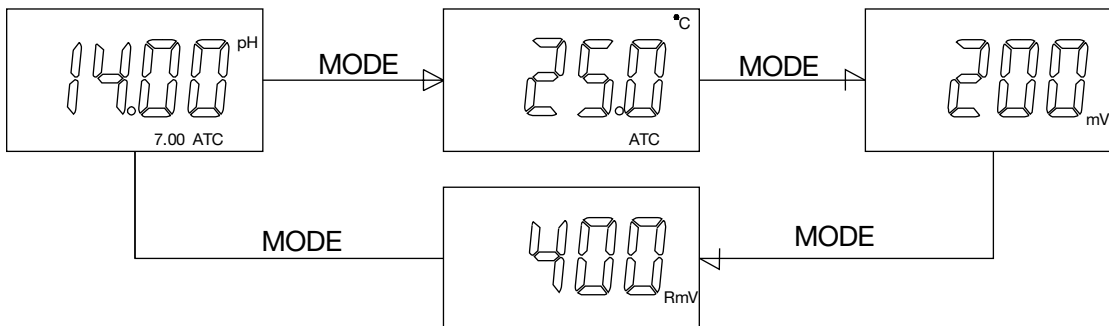

1. **pH** – The degree of acidity or alkalinity of the solution.
2. **Temperature** – Current temperature of the solution.
3. **ORP mV** – A measurement of absolute ORP mV.
4. **ORP RmV** – A measurement of relative ORP mV. The offset value at the RmV calibration will be added to the ORP absolute value to display the ORP relative value.

Note: ORP relative value range: ORP absolute value - 1000mV to ORP absolute value + 1000mV Pressing [MODE] key in the Measure mode will cycle the display from the four modes above.

INSTALLATION

SETTINGS MODE

Pressing **[DOWN]** key and **[ENTER]** key at the same time, the meter will enter into the Setting mode.

1. Temperature compensation select:

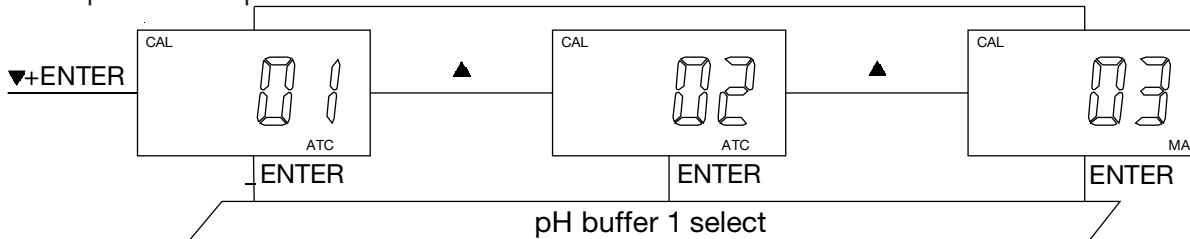

Pressing **[UP]** key or **[DOWN]** key in this screen will cycle the display from 01 (Thermistor: 10k ohm), 02 (Resistor: PT1000), 03 (Manual) modes above.

Select the preferred temperature compensation mode, press **[ENTER]** key to save, and enter the next setting screen.

PH BUFFER 1 SELECT:

Pressing **[UP]** key or **[DOWN]** key in this screen will cycle the display from 7.00, 6.86 buffer above.

Select the preferred buffer, press **[ENTER]** key to save, and enter the next setting screen.

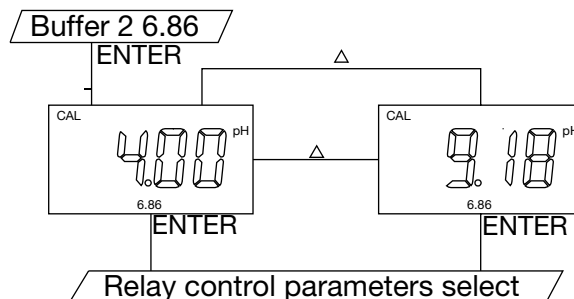
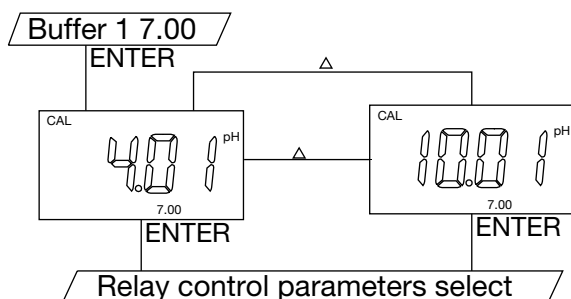
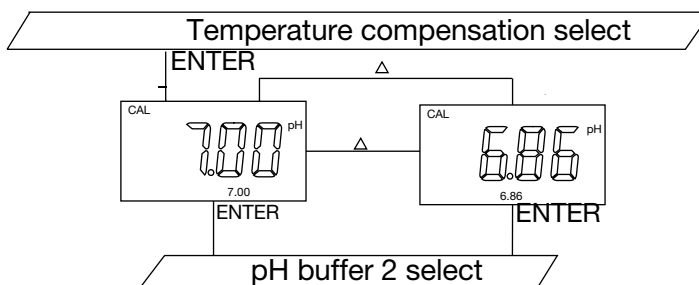

Pressing **[UP]** key or **[DOWN]** key in this screen will cycle the display from 4.01, 10.01 (or 4.00, 9.18) buffer above. Select the preferred buffer, press **[ENTER]** key to save, and enter the next setting screen.

Note: The pH buffer 2 is either 4.01 or 10.01 if select 7.00 buffer at pH buffer 1 select screen. The pH buffer 2 is either 4.00 or 9.18 if select 6.86 buffer at pH buffer 1 select screen.

INSTALLATION

RELAY CONTROL PARAMETERS SELECT:

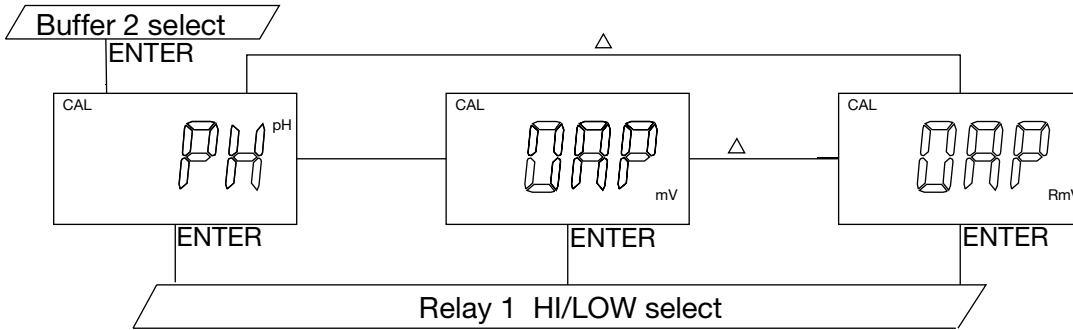

Pressing **[UP]** key or **[DOWN]** key in this screen will cycle the display from pH, ORP mV ORP RmV modes above. Select the preferred mode, press **[ENTER]** key to save, and enter the next setting screen.

Note: The relay will work with the choice of parameters.

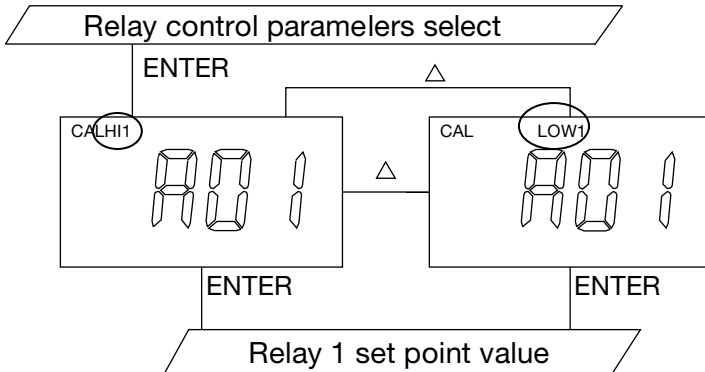

Pressing **[UP]** key or **[DOWN]** key in this screen will cycle the display from HI, LOW modes above. Select the preferred mode, press **[ENTER]** key to save, and enter the next setting screen.

Note: See "Controlling the relays" page.

Relay 1 set point value:

Pressing **[UP]** key or **[DOWN]** key in this screen to adjust the value, press **[ENTER]** key to save, and enter the next setting screen.

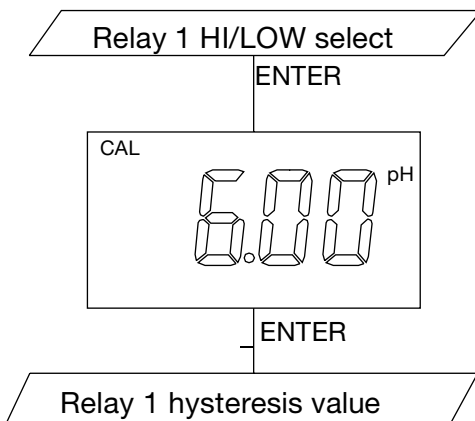

INSTALLATION

Relay 1 hysteresis value:

Pressing [UP] key or [DOWN] key in this screen to adjust the value, press [ENTER] key to save, and enter the next setting screen.

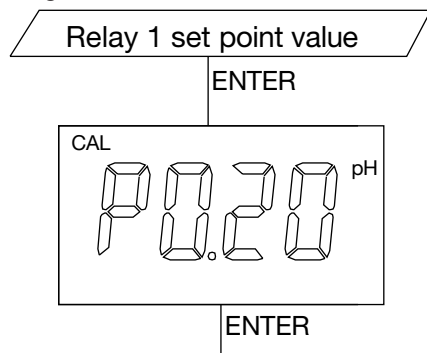

Relay 2 HI/LOW select

Relay 2 High / Low select: Same as "Relay 1 work way select"

Relay 2 set point value: Same as "Relay 1 set point value"

Relay 2 hysteresis value: Same as "Relay 1 hysteresis value"

PH CALIBRATION MODE

The TX20 uses 2-point calibration for pH. The first point must be 6.86/7.00, and the second point can either be 4.00/4.01 or 9.18/ 10.01.

In the pH Measure mode, pressing [UP] key and [ENTER] key at the same time to allow the meter to go to the pH Calibration mode.

CONTROLLING THE RELAYS

1. ISOLATION VOLTAGE:

The maximum isolation voltage of the relay output contacts is 1500 VDC. The voltage differential between the relay output contacts and the load should not exceed 1500 VDC.

2. OUTPUT LOAD:

The current through the relay output contacts should not exceed 5 Amp at 115 VAC and 2.5 Amp at 230 VAC in order not to cause permanent damage to the relay contacts. This rating is specified for resistive loads only.

3. RELAY ACTION, RELAY SET POINT AND HYSTERESIS VALUE:

Relay Action	Effective RELAY-ON Set Point	Effective RELAY-OFF Set Point
HI	S.P. + (1/2 H.V)	S.P. - (1/2 H.V)
LOW	S.P. - (1/2 H.V)	S.P. + (1/2 H.V.)

If the relay action is set to **HIGH**, the relay will turn **ON** at (Set Point +1/2 Hysteresis), and will turn **OFF** at (Set Point -1/2 Hysteresis).

If the relay action is set to **LOW**, the relay will turn **ON** at (Set Point -1/2 Hysteresis), and will turn **OFF** at (Set Point +1/2 Hysteresis).

There are two Independent relays the user can bind to the **pH**, **ABSOLUTE mV** or **RELATIVE mV mode**. The user can only bind the two relays to one reading mode at a time. The user can change this anytime by changing option at the **setting mode**.

Note:

1. The ideal set point range for pH is 0.00 to 16.00 pH.
2. The ideal set point range for absolute mV is -2000 to 2000 mV.
3. The ideal set point range of for relative mV is -3000 to 3000 mV.

OPERATION

OPERATION:

At this point the PH and ORP control system is ready for operation. The system will now read the PH and ORP of the water and the metering pump will activate when the PH or ORP is out of the range of the desired set point.

NOTE: If the metering pump is activated but the rollers fail to spin, the rollers of the pump might be stuck. You should be able to manually spin the roller by hand to get these started. Add lubricant to the rollers if the problem persists.

FINAL pH AND ORP SYSTEM SETUP:

1. Place the hoses from the **pH and ORP Pumps** into the **Adjustment Chemicals**.
 - a. The recommended pH chemical for this system is aluminum sulfate.
 - b. The recommended ORP chemical for this system is bleach or sodium hypochlorite at 5%.
2. Turn on the **pH and ORP Pump Switches**. Chemicals will be inserted into the water as necessary.

SETTING OF THE WATER RECYCLING TIMER:

1. Dormant water creates bacteria buildup and odor. If the water recycling treatment system is going to be dormant for more than three hours, a water recycle mode should be setup.
2. The water recycling treatment system should be set to recycle in accordance with the unit dormant time.

Example 1: If the unit will be dormant for approximately 10 hours, the recycle time should be set to run for 3-4 hours half way between the dormant time.

Dormant time: 8:00 p.m. to 6:00 a.m.
Recycle time: 11:00 p.m. to 3:00 a.m.

Example 2: If the unit will be dormant for approximately 3 hours, the recycle time should be set to run for 1 hour half way between the dormant time.

Dormant time: 2:00 a.m. to 5:00 a.m.
Recycle time: 3:00 a.m. to 4:00 a.m.

NOTE: If odor is still present, increase recycle times.

3. Disconnect power to the system and open the **Control Panel (38)**. Located inside the **Control Panel (38)**, the water recycling timer consists of individual pins which surround a 24 hour clock display.
 - a. Turn the dial until the arrow points to the correct time.
 - b. Each pin represents 1/2 hour of water recycling time.
 - c. Using your fingertips, pull the amount of pins needed for water recycling time to correspond to the clock on the timer.
 - d. The water recycling treatment system will automatically recycle during the set time.
4. Close the **Control Panel (38)** and reconnect power supply.

WATER RECYCLING TIMER

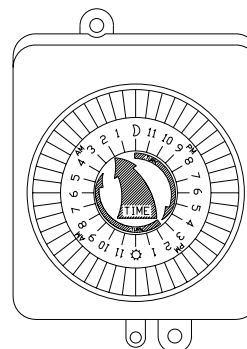

WLP-0012-112098-JJ

BEGIN:

1. The water recycling treatment system is now ready to operate.
2. Ensure all switches on the **Control Panel (38)** are on.
3. Monitor the system closely the first few days to ensure smooth operation.

MAINTENANCE

WASTE OIL DECANTER:

1. The **Oil Skimmer (11)** removes the top layer of oil and water from the **Oil/Water/Solids Separator (7)** and places it in the **Waste Oil Decanter (12)**. As the **Waste Oil Decanter (12)** fills with the oil/water mixture, the oil will float to the top while the water remains on the bottom. The water then moves out of the bottom of the tank and back to the pit to be recycled again. As the amount of oil accumulates, it will have to periodically be removed from the **Waste Oil Decanter (12)** to prevent it from building up and flowing out of the bottom of the **Waste Oil Decanter (12)**.
 - a. Place a 5 gallon bucket below the hose on the Oil Release Valve 6.
 - b. Open the Oil Release Valve 6 and allow oil to flow into the 5 gallon bucket. Turn off valve when water begins flowing into the bucket.
 - c. Dispose of oil according to EPA Standards.

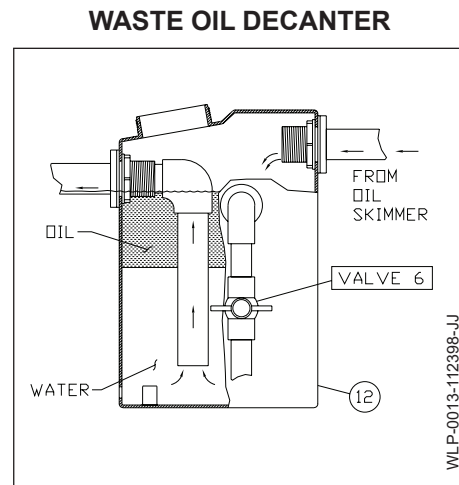

SOLIDS COLLECTION AREA:

The solids collection area of the **Separator Tank (9)** will need to be cleaned occasionally to prevent overflow of solids into the **Holding Tank (14)**. This could be done one of two ways. In either situation, do not use pressure washers while performing this maintenance.

1. Using 2" PVC, plumb a discharge line with a shut-off valve from the solids collection area back to the **Wash Water Catch Pit (1)**, or other settling area. This will allow manual control of solids flow out of the water recycling treatment system, eliminating the need to stop the unit and clean the **Separator Tank (9)**.
2. If a discharge line is not hooked up to the solids collection area, the unit will need to be stopped for cleaning purposes.
 - a. Turn the **Sump Pump Switch (40)** to off.
 - b. Place a catch basin under the solids collection area drain.
 - c. Open the drain at the bottom of the solids collection area.
 - d. Allow water and solids to flow out of **Separator Tank (9)**.
 - e. Hook a hose up to the **Rinse Water Outlet (33)**.
 - f. Wash out the solids collection area. The **Oil Coalescing Grid (10)** and baffles may be removed at this time for more thorough cleaning.
 - g. When clean, reinsert the **Oil Coalescing Grid (10)** and baffles if applicable.
 - h. Turn the **Sump Pump Switch (40)** to on.
 - i. Solids collected in the catch basin should be returned to the **Wash Water Catch Pit (1)** or disposed of according to EPA standards.

BACKWASHING OF FILTERS:

1. Backwashing removes debris from the filters and sends the sediments back to the pit where they will settle. Always backwash the filters if the **Indicator Light (47)**/audio alarm turns on. The **Multi-Media Filter Pressure Gauge (34)** should be checked daily for pressure elevation. When the pressure difference between the **Multi-Media Filter Pressure Gauge (34)** and **Polishing Filter Pressure Gauge (36)** registers more than 10 PSI, the **Multi-Media Filter (21)** needs to be cleaned even if the **Indicator Light (47)** is not lit.
2. Pressure washers cannot be in use when backwashing any filters.
3. When performing backwash maintenance, backwash the **Polishing Filter (24)** immediately after backwashing the **Multi-Media Filter (21)**. When backwashing is complete, be certain to clean the **Cartridge Filter (22)** (see page 24).

CAUTION!

Filter Pump Switch (41) must be turned off before repositioning any valves on the Filters! Failure to do so can cause equipment damage.

MAINTENANCE

a. Multi-Media Filter (21) & Polishing Filter (24):

1. Turn the **Filter Pump Switch (41)** to OFF.
2. Set the Multi-Media Filter Valve 3 to "Backwash".
3. Turn the Filter Control Valve 2 one rotation short of completely closed.
4. Turn the **Filter Pump Switch (41)** to ON.
5. Press the **Backwash Switch (48)** until the **Filter Pump (19)** turns on.
6. Set the Filter Control Valve 2 to adjust the rate on the **Flow Meter (20)** as listed:

WLP-8
10 GPM

WLP-20
15 GPM

WLP-40
20 GPM

CAUTION!

Do not set flow above chart. If flow is set too high, water will begin pushing the filtering agent out with the backwash debris.

7. When the backwash water is the same color as the incoming water, the backwashing process is complete. (Approximately 5 minutes.)
8. Turn the **Filter Pump Switch (41)** to OFF.
9. Set the Multi-Media Filter Valve 3 to "Filter"
10. Set the Polishing Filter Valve 4 to "Backwash".
11. Turn the **Filter Pump Switch (41)** to ON. If the **Filter Pump (19)** does not turn on, press the **Backwash Switch (48)** until the **Filter Pump (19)** turns on.
12. Set the Filter Control Valve 2 as listed in #6, above. See "Caution" above.
13. Backwash approximately 5 minutes.
14. Turn the **Filter Pump Switch (41)** to OFF.
15. Set the Polishing Filter Valve 4 to "Filter"
16. Turn the **Filter Pump Switch (41)** to ON.
17. Clean **Cartridge Filter (22)** as explained below.

b. Cartridge Filter:

When the pressure difference between the **Cartridge Filter Pressure Gauge (35)** and the **Polishing Filter Pressure Gauge (36)** is more than 10 PSI, it is time to clean the **Cartridge Filter (22)**.

1. Turn the **Filter Pump Switch (41)** to OFF.
2. Open the Cartridge Filter Drain Valve 5 to allow water to be released from the **Cartridge Filter (22)**.
3. Open the **Air Bleed Valve (23)** to allow air to displace the outgoing water.
4. When water is drained from tank, unscrew the center ring.
5. Loosen the hand release clamp and pull out filters.

CARTRIDGE FILTER

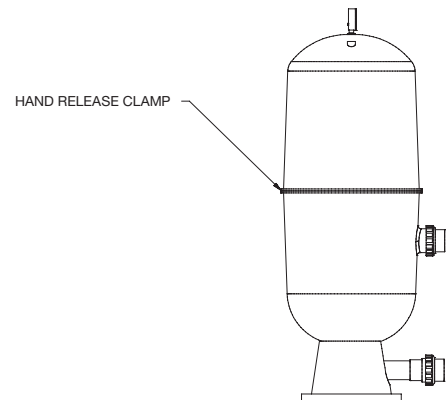

CAUTION!
Risk of Bodily Injury! Filters may weigh up to 70 pounds each. Use caution when lifting the filters.

6. Use a garden hose to spray clean the filter(s).
7. Rinse out the **Cartridge Filter (22)** tank.
8. If filter(s) are in good condition, reinsert them into the **Cartridge Filter (22)**. If excessive wear is noted, replace with new filter(s).
9. Lubricate the o-ring with petroleum jelly and replace around the outside of the **Cartridge Filter (22)** body.
10. Reinstall the tank lid.
11. Reinstall and tighten the center ring.
12. Close the Cartridge Filter Drain Valve 5 to stop water from flowing out the bottom of the **Cartridge Filter (22)** tank.
13. Turn the **Filter Pump Switch (41)** to ON.
14. Leave the **Air Bleed Valve (23)** open as the tank fills with water. Close completely when water begins to emerge from the **Air Bleed Valve (23)**.

MAINTENANCE

ACTIVE CARBON TEST:

To ensure the **Polishing Filter (24)** is working effectively, you should perform an active carbon test.

- I. **TEST PROCEDURE A:** For systems with pH & ORP Control, your test kit will include test strips.
 - A. Following the directions included with the test strip kit, test the water in the **Holding Tank (14)**.
 1. The test strip should show chlorine present in the system.
 2. If no chlorine is present, check the following:
 - a. The **ORP Adjustment Chemical (17D)** is empty. Replace.
 - b. The **ORP Pump (17C)** is turned off or malfunctioning. Ensure the **ORP Pump Switch (45)** is in the ON position. Contact your local distributor if additional maintenance is needed.
 - c. If you are not using chlorine as an ORP control, you must refer to TEST PROCEDURE B to ensure the carbon is still active.
 - B. With the **Filter Pump (19)** operating, use a test strip to test the incoming water to the **Product Tank (25)**.
 1. The test should not show chlorine present in the system.
 2. If chlorine is present, the carbon must be replaced. See REMOVING AND REFILLING MEDIA section pg. 26.
- II. **TEST PROCEDURE B:** For systems without pH & ORP Control, your test kit will include a Carbon removal scoop, 4 oz. empty container, 2 oz. empty container, 2 oz. bottle of chlorine, Chlorine test paper with color chart. Contact your local distributor if any parts are missing.
 - A. Turn off the **Filter Pump Switch (41)**.
 - B. Unscrew the six head bolts and remove the *Polishing Filter Valve 4*.
 - C. Remove the following items from the **Polishing Filter (24)** tank in the order given:
 1. Upper dispersing cup.
 2. Small section of PVC.
 3. Lower dispersing cup.
 - D. Fill the Carbon Removal Scoop with a sample of carbon from the **Polishing Filter (24)** tank.
 - E. Add 2 oz. of the carbon sample into the 4 oz. empty container.
 - F. Fill the 2 oz. empty container with water.
 - G. To the water, add one drop of chlorine.
 - H. Follow the directions on the bottle of test strips. Dip a chlorine test paper into the 2 oz. container. The chlorine reading should be at least 10 parts per million. If not, add another drop of chlorine.
 - I. Add the 2 oz. of chlorine/water solution to the carbon sample in the 4 oz. container.
 - J. Tightly cap the chlorine/carbon mixture and shake occasionally for 3 minutes.
 - K. Dip a new strip of chlorine test paper into the liquid part of the 4 oz. container. Do not dip the test paper into the solid carbon as this will produce incorrect results. Read the directions on the bottle of test strips.
 - L. Check the reading against the color chart.
 1. A reading of zero means the carbon is still active.
 - a. Reassemble the dispersing section of the **Polishing Filter (24)** and replace the *Polishing Filter Valve 4*.
 - b. Turn the **ORP Pump Switch (45)** on.
 2. A positive reading means the carbon is inactive and must be recharged or replaced. Refer to pg. 26.

MAINTENANCE

REMOVING & REFILLING MEDIA FROM THE MULTIMEDIA & POLISHING FILTER:

1. New media can be ordered from your local distributor.

Model	Description	Quantity	Weight (lbs.)
WLP-08	24" Media filter	1	
	Gravel #3		100
	Garnet #12		100
	Garnet #50		100
	Filter Ag		50
WLP-20	20" Media filter	1	
	Activated carbon 12x40 mesh	1.5 bags	68
	30" Media filter	1	
	Gravel #3		200
	Garnet #12		100
WLP-40	Garnet #50		200
	Filter Ag		50
	24" Media filter	1	
	Activated carbon 12x40 mesh		110
	36" Media filter	1	
WLP-40	Gravel #3		300
	Garnet #12		200
	Garnet #50		300
	Filter Ag		100
	24" Media filter	1	
	Activated carbon 12x40 mesh		110

2. Be certain to wear proper attire such as goggles, gloves, coveralls, dust mask, etc. to protect eyes and skin.
3. Turn off the **Filter Pump Switch (41)**.
4. Remove the valve from the desired filter tank.
5. Remove the following items from the filter tank in the order given:
Upper dispersing cup, Small section of PVC, Lower dispersing cup.
6. Use a vacuum to remove the media from the filter.
7. Cover the PVC opening to prevent media from entering the laterals.
8. Ensure the lateral assembly remains centered and flush on the bottom of the tank and the layers are level when pouring media into the filter tank.
9. Reassemble the dispersing section of the filter tank and replace its corresponding valve.
10. Turn on the **Filter Pump Switch (41)**.
11. Dispose of used media according to EPA standards.

MAINTENANCE

WATER TESTING

Water chemical makeup should be tested on a weekly basis. With the **Sump Pump (4)** operating, use a test strip, test the incoming water to the **Holding Tank (14)**. (Follow the directions given with your test strips.) Use the flow chart below to check and correct the following:

1. pH: Acidity and alkalinity in the water. Low pH (acidic) will cause rusty looking water.
2. Alkalinity: Dissolvable salts in the water. Too much alkaline causes cloudiness and reduces filter life.
3. Calcium Hardness: Calcium in the water. Too much calcium creates scale buildup in coils of hot water pressure washers.
4. *Free Chlorine: Chlorine which is not combined with dirt, oils, etc. Controls odor, bacteria and algae formation.
*If using chlorine as a water purifying agent.

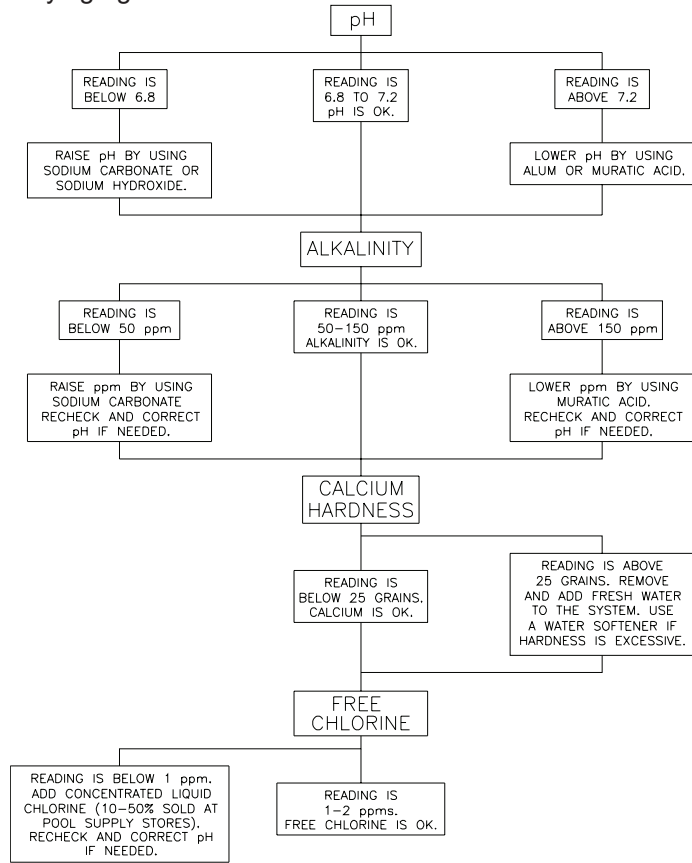

WLP-0015-112398-JJ

MAINTENANCE:

1. Clean pH AND ORP probes every 1-2 months.
 - a. Shut off sump pump, wait for drain line to drain and loosen aluminum strain relief around probe to remove.
 - b. Use water or vinegar and a soft cloth or Q-tip to wipe away build up on the probe.
 - c. Place probe back in line, with tip at center of piping. Tighten strain relief around probe. **DO NOT OVERTIGHTEN.**

Note: probes will be damaged if they are allowed to dry out. If they will be exposed to air for more than a few hours keep tip submerged in water or the storage solution that comes with the probe.

Note: probes have a shelf life of about 1 year so it's recommended to replace the probes yearly.
2. Calibration of pH meter. You should recalibrate the external meter 1 or 2 times a year. You should also always recalibrate the meter when a pH probe has been replaced. Follow the calibration instructions below for the pH meter. An electronic calibrator can be used in place of the buffer solutions.

MAINTENANCE

BUFFER 1 (STAND) CALIBRATION:

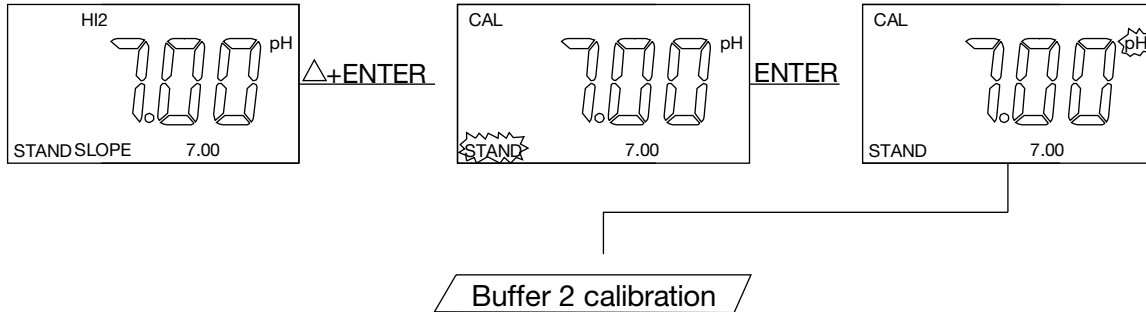

Enter into the pH calibration mode, the “STAND” icon will flash, the unit is ready to be standardized at the first buffer. Rinse the pH and ATC/Temp probes in distilled water and immerse them in the first buffer solution (either 7.00 or 6.86). Allow temperature reading to stabilize, then press “ENTER” key to calibrate. The “pH” icon will flash until the unit detects a stable reading. Once the unit calibrates the first point, the “SLOPE” icon will flash. The unit is ready to be sloped at the second buffer.

BUFFER 2 (SLOPE) CALIBRATION:

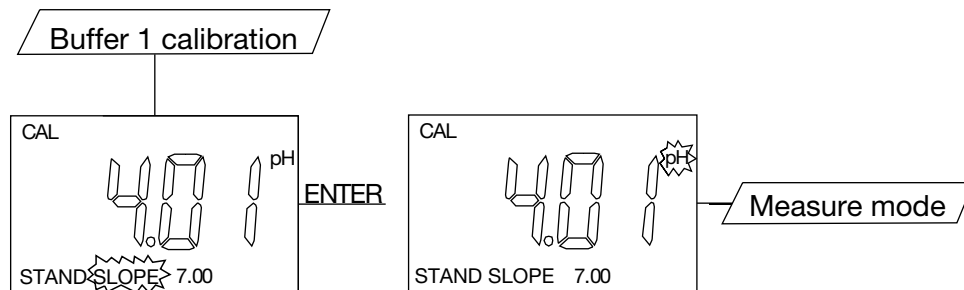

Rinse the pH and ATC/Temp probe in distilled water and immerse them in the second buffer solution (either 4.00/4.01 or 9.18/10.01). Allow temperature reading to stabilize, then press “ENTER” key to calibrate. The “pH” icon will flash until the unit detects a stable reading. Once the unit calibrates the second point and the unit will automatically exit the calibration mode and goes to the pH Measure mode. Dual point calibration is complete.

Note: In the Setting mode (1. Temperature compensation select), select 03 (Manual temperature compensation mode) if no temperature probe is being used. Press the [UP] key or [DOWN] key in the Manual temperature compensation mode to adjust the value to that of the test solution temperature. Then calibrate buffer 1 and buffer 2.

ORP CALIBRATION:

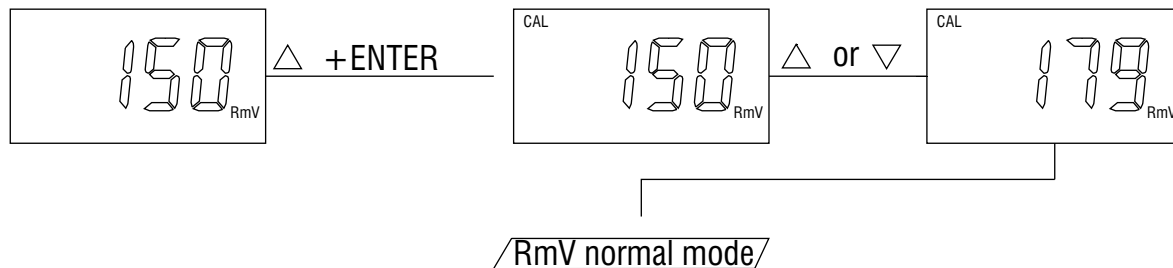

The model TX20 uses 1-point calibration for RmV. In the **RmV Measure mode**, pressing [UP] key and [ENTER] key at the same time, the meter will enter into **RmV calibration mode**. Rinse the ORP probe in distilled water and immerse it in the ORP standard solution, then press [UP] or [DOWN] key to adjust the ORP value to that the ORP standard. Press [ENTER] key to save. The unit beeps to indicate a successful calibration. Calibration is now complete and the unit will automatically switch to the ORP relative mV **Measure mode**.

MAINTENANCE

WINTERIZING:

If you must store your unit in an area where the temperature may fall below 32°F/0°C, you can protect your water recycling treatment system by draining all water from the system.

1. Follow the backwashing/cleaning procedures outlined on pages 23-24 for the **Multi-Media Filter (21)**, **Polishing Filter (24)** and **Cartridge Filter (22)**, but DO NOT refill the **Cartridge Filter (22)**.
2. Turn all switches on the **Control Panel (38)** to the OFF position and disconnect power to the **Control Panel (38)**.
3. Open the check valve near the **Sump Pit (3)** and drain the water transport line. Remove the **Sump Pump (4)** from the **Sump Pit (3)**.
4. Set the *Multi-Media Filter Valve 3* and the *Polishing Filter Valve 4* to "Winterize".
5. Remove drain plug from **Multi-Media Filter (21)** and **Polishing Filter (24)**.
6. Open the *Cartridge Filter Drain Valve 5* and open the **Air Bleed Valve (23)**. Break the unions on each side.
7. Remove the drain plug from the **Filter Pump (19)**.
8. Remove the drain plug from the **Transfer Pump (26)**.
9. Remove the drain plug from the solids collection area on the **Separator Tank (9)** and clean the tank.
10. Remove the remaining drain plugs from the **Oil/Water/Solids Separator (7)** and wipe down the **Oil/Water/Solids Separator (7)**.
11. Remove the **pH and ORP Sensor Probes (16A & 17A)** and place them in their original containers filled with deionized water. Store at room temperature.
12. Drain the pH and ORP lines and break the unions.
13. Store all chemicals at room temperature.

TROUBLESHOOTING

SYMPTOM	PROBABLE CAUSE	REMEDY
<i>ELECTRICAL</i>		
No power at Control Panel (38) .	Power failure to Control Panel (38) .	Check circuit breaker at power source or contact your local distributor.
Power Indicator Light (39) is OFF.	Blown fuses inside Control Panel (38) on step down transformer.	Check fuses, replace if necessary. If fuses are OK, contact your distributor.
<i>SUMP PUMP</i>		
Sump Pump (4) will not run.	Floats are not adjusted correctly in the Sump Pit (3) .	Readjust.
	Not enough water in the Sump Pit (3) .	Add water to the Sump Pit (3) .
	Float 1 is defective.	Replace.
	Level Limit Switch (49) in the Separator Tank (9) has flipped up.	Push Level Limit Switch (49) down, or remove excess water in the Separator Tank (9) .
	Circuit overload/breaker has tripped.	Reset breaker or replace fuse at power source.
	Motor overload.	Allow motor to cool. Motor will automatically restart when cool.
Sump Pump (4) motor starts and stops frequently.	Motor is defective.	Replace motor.
	This is a common occurrence on initial start-up while pits are filling.	Allow pits to fill.
	Excessive water flow to reclaim unit.	Turn valve clockwise to reduce flow.
	Sump Pump (4) impeller is clogged.	Disconnect power and unclog impeller.
	Motor overload.	Allow motor to cool. Motor will automatically restart when cool.
	Sump Pit (3) is not large enough.	Expand size of pit.
Sump Pump (4) runs, but there is little or no water discharge.	Strainer basket in Sump Pump (4) is clogged.	Clean, repair or replace.
	Water level is below pump inlet.	Ensure Float 1 is not caught in plumbing.
	There is an air lock in the Sump Pump (4) .	Manually fill the inlet pipe with water. Turn the Sump Pump (4) on and off several times.
	Low voltage.	Ensure wire size is capable of handling the rated amperage of the unit. If wire size is correct, contact your distributor.
	Clogged impeller or worn pump parts.	Contact your distributor.
Sump Pump (4) will not turn off.	Defective switch inside Float 1.	Replace.
	Pump is air locked.	Cycle pump in one minute increments several times to clear air from pump. If system includes a check valve, a 3/16" hole should be drilled in the discharge pipe approximately 2" above the discharge connections.

TROUBLESHOOTING

SYMPTOM	PROBABLE CAUSE	REMEDY
<h3>SEPARATOR TANK</h3>		
Water will not flow into the Separator Tank (9) .	Sump Pump (4) is not turned on.	Move Sump Pump Switch (40) to "ON".
	Circuit breaker has tripped or is "OFF".	Reset or turn breaker "ON".
	Level Limit Switch (49) in coalescing tank is malfunctioning.	Check On/Off with voltmeter, repair or replace.
	Vertical coalescing in the Ozone Contact Tank (8) is clogged.	Remove and clean with a water hose.
	Ozone Injector (6) is plugged.	Remove Ozone Injector (6) , clean.
	Dirt is lodged in the pit check valve.	Clean.
	Sump Pump (4) impeller is clogged.	Disconnect power and clean.
	Lines or valves contain frozen water.	Allow to thaw. Inject with warm water if necessary.
<h3>FILTER PUMP</h3>		
Filter Pump (19) will not run.	Filter Pump Switch (41) is off.	Turn switch on.
	Circuit overload/breaker has tripped.	Reset breaker or replace fuse.
	Motor overload.	Allow motor to cool. Motor will automatically restart when cool.
Filter Pump (19) runs but there is no water discharge OR Filter Pump cycles excessively.	Filter Pump Switch (41) is malfunctioning.	Replace switch.
	Pump is not primed.	Manually fill the inlet pipe with water. Turn the Filter Pump (19) on and off several times.
	Pump sucking air.	Eliminate leaks and tighten all connections on intake line.
	Low water in Holding Tank (14) .	Increase flow by opening <i>Water Inlet Flow Control Valve 1</i> .
	Rain Water Overflow (30) is discharging too much water.	Reduce flow by adjusting solenoid on the Rain Water Overflow (30) .
	Check valve is leaking or stuck in closed position.	Clean or replace as necessary.
	Filters are dirty.	Backwash filters. (See pg. 23-24.)
	Lines or valves contain frozen water.	Allow to thaw. Inject with warm water if necessary. Ensure the Sump Pit (3) remains above freezing.
	Pump impeller is obstructed.	Contact your local distributor.
	Pump motor is operating below maximum RPM.	Contact your local distributor.
Filter Pump (19) is hot or turns off.	Multi-Media Filter (21) is dirty.	Backwash.
	Low voltage.	Ensure wire size is capable of handling the rated amperage of the unit. If wire size is correct, contact your local distributor.
	Motor overload.	Allow motor to cool. Motor will automatically restart when cool.

TROUBLESHOOTING

SYMPTOM	PROBABLE CAUSE	REMEDY
FILTERS		
Indicator Light (47) remains on after backwashing.	Debris is packed too tightly.	Increase backwash flow to 5 GPM above the maximum listed on pg. 24.

TRANSFER PUMP

Transfer Pump (26) runs but there is low water discharge.	Water is being used elsewhere.	Reduce flow to other source or contact your local distributor.
	Pump is not primed.	Manually fill the inlet pipe with water Turn the Transfer Pump (26) on and off several times.
	Timer kicked in. Water is recycling	Do not run pressure washers while water is in timed recycle mode.
	Rain Water Overflow (30) is discharging back to pit.	Do not run pressure washers while water is discharging.
	Plumbing is obstructed or too small.	Remove obstruction or use larger plumbing.
	Scale buildup in metal piping.	Replace with plastic plumbing.
Transfer Pump (26) cycles excessively.	Solenoid valve(s) is open or stuck open.	Fix Solenoid valve(s) or reduce flow.
	Pump sucking air.	Eliminate leaks and tighten all connections on intake line.
	Bladder failure in Pressure Tank (27) .	Replace Pressure Tank (27) .
	Pressure switch malfunction.	Adjust pressure settings.
	Too low of pressure in the Pressure Tank (27) .	Increase pressure.
Transfer Pump (26) does not turn off.	Pressure switch line is obstructed.	Disconnect line and remove obstruction. Replace.
	Pressure switch is out of alignment.	Realign or replace.
	Pressure switch contacts are frozen.	Replace if necessary.
	Impeller is obstructed.	Contact your local distributor.

SHAFT SEALS

Water is leaking at pumps.	Damaged stationary shaft seal.	Seal ran dry. Ensure seal chamber is filled with liquid.
Short seal life.	Unexpected temperature and chemical usage.	Replace.

TROUBLESHOOTING

SYMPTOM	PROBABLE CAUSE	REMEDY
SOLENOIDS		
Solenoid valve won't turn on.	Low or no water pressure.	Turn off water, switch solenoids between valves. Turn on water. If problem is corrected, replace faulty solenoid.
	No electrical contact to solenoid.	Contact your local distributor.
Solenoid valve leaks when turned off.	Solenoid is obstructed.	Turn off water, remove and clean solenoid.
	Damaged solenoid.	Replace.
	Solenoid o-ring is misaligned or damaged.	Realign or replace.
	Diaphragm seat is dirty.	Clean or replace.
	Diaphragm is damaged.	Replace.
ODOR		
Excessive odor in water system points.	Not enough chemicals in the system to maintain water balance.	Increase the pH and ORP set (See pg. 22)
	Water remains dormant in the system too long causing bacteria buildup.	Increase timer settings to recycle water.
CHEMICALS		
Excessive chemical usage.	pH and ORP Meters (16B & 17B) are calibrated incorrectly or faulty probes.	Recalibrate meters or change probes.
Low chemical usage (with possible odor.)	Chemical pumps are not working.	Replace chemical hose inside pump. Recalibrate pH and ORP Meters (16B & 17B) .
WATER FLOW		
Air shoots from Water Outlet.	This is a common occurrence while pump is priming.	Air will stop shooting from the water outlet when pump is primed.
	Transfer Pump (26) is sucking air at suction inlet.	Eliminate leaks or tighten connection.
Water will not turn off.	Solenoid failure.	Repair or replace.

TROUBLESHOOTING

pH/OPR DISPLAY	TEMPERATURE DISPLAY	DISPLAY MODE	POSSIBLE CAUSE(S) [ACTION(S)]
<u>OvEr</u>	-10.0~120.0 °C	pH measure mode	pH > 16.00pH [Recalibrate], replace probe
<u>Undr</u>	-10.0~120.0 °C	pH measure mode	pH > -2.00pH [Recalibrate], replace probe
<u>OvEr</u>	OvEr	pH measure mode	a. Temperature > 120.0 °C [Bring buffer solution to lower temperature.] [Replace temperature probe.] b. No temperature sensor. [Adjust the manual temperature to -10~120 °C.]
<u>OvEr</u>	Undr	pH measure mode	a. Temperature > -10.0 °C [Bring buffer solution to higher temperature.] [Replace temperature probe.] b. No temperature sensor. [Adjust the manual temperature to -10~120 °C.]
<u>OvEr</u>	Temperature reading	Absolute ORP mV or relative ORP	Absolute ORP mV > +1999 mV a. Bring solution down to lower ORP b. Recalibrate c. Replace probe
<u>Undr</u>	Temperature reading	Absolute ORP mV or relative ORP	Absolute ORP mV > -1999 mV a. Bring solution up to higher ORP b. Recalibrate c. Replace probe

REPLACEMENT PARTS

DESCRIPTION	REORDER PART #
Replacement Cartridge Filter for WLP-20	19-0264
Replacement Cartridge Filter for WLP-40	19-0264
Replacement Cartridge Filter for WLP-8	19-0274
pH Sensor Probe	32-0538
ORP Sensor Probe	32-0540
Activated carbon	33-0302
Gravel	33-0303
Garnet #12	33-0304
Garnet #50	33-0305
Filter Ag	33-0306
Test Strips	33-0314



STATEMENT OF WARRANTY

Mi-T-M warrants all parts (except those referred to below) of your new WLP Water recycling Treatment system to be free from defects in materials and workmanship during the following periods:

For One (1) Year from the date of original purchase:

Defective parts not subject to normal wear and tear will be repaired or replaced at manufacturer's option during the warranty period. In any event, reimbursement is limited to the purchase price paid.

EXCLUSIONS

1. The motor is covered under separate warranty by its respective manufacturer and is subject to the terms set forth therein.
2. Normal wear parts:

Seals	Filters	Gaskets
O-rings	Packings	Pistons
Valve Assembly	Brushes	Filtering Media
Sensors		
3. Parts damaged due to:
 - normal wear, misapplication, modifications/alterations, abuse,
 - operation at other than recommended speeds, pressures or temperature,
 - the use of caustic liquids,
 - chloride corrosion or chemical deterioration,
 - fluctuations in electrical or water supply,
 - operating unit in an abrasive, corrosive or freezing environment.
4. Parts damaged by failure to follow recommended:
 - installation, operating and maintenance procedures.
5. This warranty does not cover the cost of:
 - normal maintenance or adjustments,
 - labor charges,
 - transportation charges to Service Center,
 - freight damage.
6. The use of other than genuine Mi-T-M parts will void warranty. Parts returned, prepaid to the Mi-T-M's factory or to an Authorized Service Center will be inspected and replaced free of charge if found to be defective and subject to warranty. There are no warranties which extend beyond the description of the face hereof. Under no circumstances shall the Mi-T-M bear any responsibility for loss of use of the unit, loss of time or rental, inconvenience, commercial loss or consequential damages.

Manufactured by Mi-T-M
50 Mi-T-M Drive, Peosta IA 52068
563-556-7484/ Fax 563-556-1235