



OPERATORS MANUAL FOR Mi-T-M®  
***WLP AUTOMATIC***  
BACKWASH SERIES  
WATER RECYCLING TREATMENT SYSTEM



CAUTION

RISK OF INJURY!

READ MANUAL BEFORE OPERATING!

This manual is an important part of the water recycling treatment system and must remain with the unit when you sell it!

# CONTENTS

INTRODUCTION .....	3
CONTENTS OF WLP-SERIES WATER RECYCLING TREATMENT SYSTEM.....	4
SPECIFICATIONS .....	4
IMPORTANT SAFETY WARNINGS .....	5
FLOW CHART .....	8
FLOW DIAGRAM FOR THE WLP-20AB AND WLP-40AB.....	9
WLP-20AB FEATURES .....	10
WLP-40AB FEATURES .....	11
INSTALLATION .....	12
PREPARATION .....	15
INSTALLATION .....	18
OPERATION.....	23
PREPERATION .....	24
OPERATION.....	29
MAINTENANCE .....	29
TROUBLESHOOTING .....	37
STATEMENT OF WARRANTY .....	44

## WARNING

 **WARNING:** This product can expose you to chemicals including Lead, which is known to the State of California to cause cancer and birth defects or other reproductive harm. For more information go to [www.P65Warnings.ca.gov](http://www.P65Warnings.ca.gov)

## WARNING

 **WARNING:** This product can expose you to chemicals including carbon monoxide, which is known to the State of California to cause birth defects or other reproductive harm. For more information go to [www.P65Warnings.ca.gov](http://www.P65Warnings.ca.gov)

# INTRODUCTION

Congratulations on the purchase of your new water recycling treatment system! You can be assured your water recycling treatment system was constructed and designed with quality and performance in mind. Each component has been rigorously tested to ensure the highest level of acceptance.

This operator's manual was compiled for your benefit. By reading and following the simple safety, installation, operation, maintenance and troubleshooting steps described in this manual, you will receive years of trouble free operation from your new water recycling treatment system. The contents of this manual are based on the latest product information available at the time of publication. The manufacturer reserves the right to make changes in price, color, materials, equipment, specifications or models at any time without notice.

## ! IMPORTANT !

These paragraphs are surrounded by a "SAFETY ALERT BOX". This box is used to designate and emphasize Safety Warnings that must be followed when operating this water recycling treatment system.

Accompanying the Safety Warnings are "signal words" which designate the degree or level of hazard seriousness. The "signal words" used in this manual are as follows:

**DANGER:** Indicates an imminently hazardous situation which, if not avoided, WILL result in death or serious injury.

**WARNING:** Indicates a potentially hazardous situation which, if not avoided, COULD result in death or serious injury.

**CAUTION:** Indicates a potentially hazardous situation which, if not avoided MAY result in minor or moderate injury.



The symbols set to the left of this paragraph are "Safety Alert Symbols". These symbols are used to call attention to items or procedures that could be dangerous to you or other persons using this equipment.



**ALWAYS PROVIDE A COPY OF THIS MANUAL TO ANYONE USING THIS EQUIPMENT. READ ALL INSTRUCTIONS BEFORE OPERATING THIS WATER RECYCLING TREATMENT SYSTEM AND ESPECIALLY POINT OUT THE "SAFETY WARNINGS" TO PREVENT THE POSSIBILITY OF PERSONAL INJURY TO THE OPERATOR.**



Once the unit has been removed from the crate, immediately write in the serial number of your unit in the space provided below.

**SERIAL NUMBER** \_\_\_\_\_

Inspect for signs of obvious or concealed freight damage. If damage does exist, file a claim with the transportation company immediately. Be sure that all damaged parts are replaced and that the mechanical and electrical problems are corrected prior to operation of the unit. If you require service, contact your customer service representative.

Please have the following items available for all Service calls:

1. Model Number
2. Serial Number
3. Date and Place of Purchase

# CONTENTS OF WLP-SERIES WATER RECYCLING TREATMENT SYSTEM

Carefully unpack your new WLP-Series Water recycling treatment system. Check the contents against the packing list. Contact the freight line if a damage claim is required on any component. The following items are the basic equipment sent with your WLP-Series Water recycling treatment system.

1. Water recycling treatment system Platform
  - a. Sump Pump
  - b. Coalescer Type Oil Separator
  - c. Ozone Generator
  - d. Filter Pump
  - e. Filter Flow Meter
  - f. Multi-Media Filter
  - g. Polishing Filter
  - h. Transfer Pump
  - i. Pressurized Water Storage Tank
  - j. Waste Oil Decanter
2. Three Unattached Floats for Sump Pit
  - a. Blue: Protects sump pump low level.
  - b. Red: To fill pit from the fresh water inlet.
  - c. Green: High pit level discharge.
3. Water Test Kit
4. Manual
5. pH Sensor Probe
6. ORP Sensor Probe
7. Air Dryer

## SPECIFICATIONS

MODEL	WLP-20AB-0M11	WLP-20AB-0M31	WX-0054 (460V 20AB-0M31)	WLP-40AB-0M11	WLP-40AB-0M31	WX-0055 (460V 40AB-0M31)
MAX FLOW	20 GPM			40 GPM		
ELECTRICAL	230 VOLT / 1 PHASE / 24 MAX AMP	208/230 VOLT / 3 PHASE / 12 MAX AMP	460 VOLT / 3 PHASE / 8 MAX AMP	230 VOLT / 1 PHASE / 30 MAX AMP	208/230 VOLT / 3 PHASE / 16 MAX AMP	460 VOLT / 3 PHASE / 8 MAX AMP
SUMP PUMP	1 HP					
OZONE GENERATOR	MEDIUM FLOW					
OIL COALESCING AREA	576 SQUARE FEET			1152.0 SQUARE FEET		
FILTER PUMP	1 HP			1 HP		
MULTI-MEDIA FILTER	550 LBS			900 LBS		
POLISHING FILTER	110 LBS DEGASSED			165 LBS DEGASSED		
TRANSFER PUMP	3/4 HP			2 HP		
DIMENSIONS	96" X 60" X 60"			84" X 108" X 60"		
NET WEIGHT	2000 LBS			3200 LBS		



## IMPORTANT SAFETY WARNINGS



**WARNING:** When using this product, basic precautions should always be observed, including the following:  
**READ ALL SAFETY WARNINGS BEFORE USING WATER RECYCLING TREATMENT SYSTEM**





HAZARD	POTENTIAL CONSEQUENCE	PREVENTION
<p data-bbox="180 239 537 296"><b>RISK OF ELECTRIC SHOCK OR ELECTROCUTION</b></p> 	<p data-bbox="558 239 974 457">Serious injury or death could occur if the water recycling treatment system is not properly grounded. Your water recycling treatment system is powered by electricity and may cause electric shock or electrocution if not installed properly.</p> <p data-bbox="548 949 980 1041">Electrical shock may occur if water recycling treatment system is not operated properly.</p> <p data-bbox="548 1201 980 1293">Serious injury or death may occur if electrical repairs are attempted by unqualified persons.</p>	<p data-bbox="997 239 1529 331">Installation of this unit, including all electrical connections, must comply with all local, state and national codes.</p> <p data-bbox="997 352 1529 537">This product must be grounded. Connect to a GFCI circuit breaker when available. If the unit should malfunction or breakdown, grounding provides a path of least resistance for electric current to reduce the risk of electric shock. Do not ground to a gas supply line.</p> <p data-bbox="997 558 1529 714">Improper connection of the equipment-grounding conductor can result in a risk of electrocution. Check with a qualified electrician or service personnel if you are in doubt as to whether the system is properly grounded.</p> <p data-bbox="997 735 1529 890">Always be certain the unit is receiving proper voltage (+/- 5% of the voltage listed on the nameplate). Before installing electrical connections, be certain the power switches are in the "OFF" position.</p> <p data-bbox="997 911 1529 936">Keep all connections dry and off the ground.</p> <p data-bbox="997 957 1529 1045">DO NOT allow metal components of the water recycling treatment system to come in contact with live electrical components.</p> <p data-bbox="997 1066 1529 1188">Never operate the water recycling treatment system with safety guards/covers removed or damaged. Ensure all electrical covers are securely in place when unit is operating.</p> <p data-bbox="997 1209 1529 1360">Any electrical wiring or repairs performed on this water recycling treatment system should be done by Authorized Service Personnel in accordance with National and Local electrical codes.</p> <p data-bbox="997 1381 1529 1726">Before opening any electrical enclosure, always shut off the water recycling treatment system and drain the water. Disconnect the water recycling treatment system from the power source. If the power disconnect is not in sight, lock it in the open position and tag it to prevent power usage. (Never assume the water recycling treatment system is safe to work on just because it is not operating, it could restart at any time! Always disconnect from the power source.)</p>



# IMPORTANT SAFETY WARNINGS

READ ALL SAFETY WARNINGS BEFORE USING WATER RECYCLING TREATMENT SYSTEM

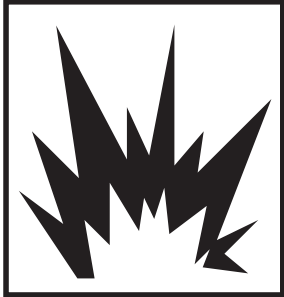

HAZARD	POTENTIAL CONSEQUENCE	PREVENTION
<p><b>RISK OF EXPLOSION OR FIRE</b></p>  	<p>Serious injury or death could occur from an explosion or fire caused by a system electric spark.</p>	<p>This unit must be placed in an area that is well ventilated, free of flammable vapors, combustible dust, gases or other combustible materials.</p>
<p><b>RISK OF BURSTING</b></p> 	<p>Serious injury or death could occur from bursting caused by excessive pressure in the system.</p> <p>Serious injury may occur if attempting to start the water recycling treatment system when the pump is frozen.</p>	<p>Do not mistreat the pressure gauges on the system. Pressure gauges will malfunction if they are subjected to excessive pressure, vibration, pulsation or temperature or if they are placed in an environment which causes corrosion of parts. Incorrect readings on a pressure gauge could mislead the operator and place him in a dangerous working condition.</p> <p>Do not use a booster pump or any type of additional pumping system. Pressurizing the suction of the pump may cause the pump body to explode.</p> <p>Do not use this water recycling treatment system to pump flammable material! An explosion could occur from a gas vapor buildup inside the system.</p> <p>In freezing temperatures, the unit must always be warm enough to ensure there is no ice formation in the pump. Do not start the water recycling treatment system if it has been in a freezing environment without first allowing the pump to thaw.</p>
<p><b>RISK OF BURNS</b></p> 	<p>Serious injury may occur from touching the electrical motor. This area can remain hot for some time after the water recycling treatment system is shutdown.</p>	<p>Never allow any part of your body to contact the electrical motor until cooled.</p>



# FLOW CHART

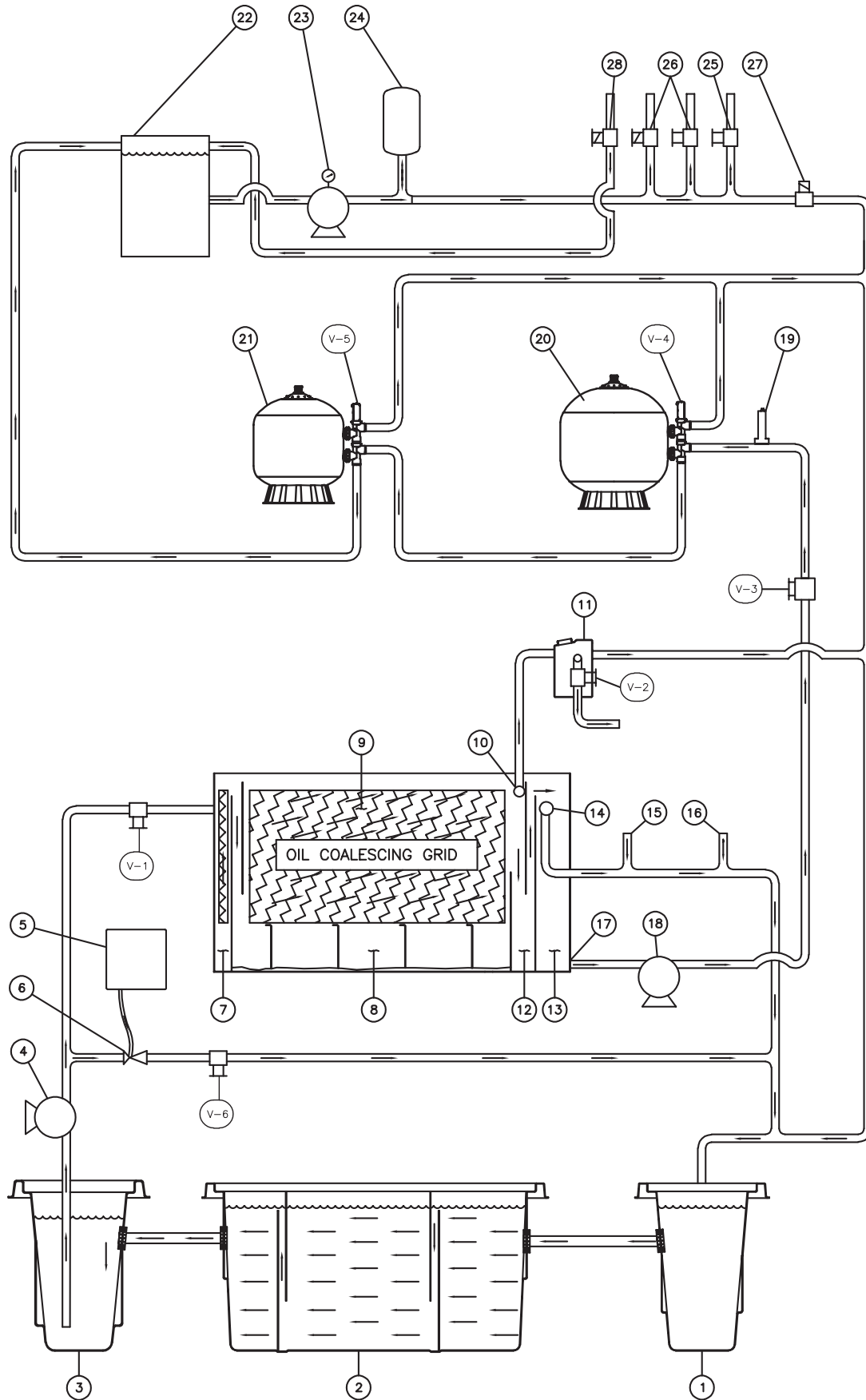

FLOW DIAGRAM WLP-20AB\_40AB 092519 MLK



## FLOW DIAGRAM FOR THE WLP-20AB AND WLP-40AB

As pressure washers are being operated, used water flows into the **Wash Water Catch Pit (1)**. From there, it moves to the **3-Stage Collection Pit (2)**. Heavy debris falls to the bottom of the pit where it is trapped by a weir which is designed to stop heavy debris while allowing the remaining water to move into the **Sump Pit (3)**. The **Sump Pump (4)** draws water from the **Sump Pit (3)** and brings it to the **Inlet Chamber (7)** through the *Water Inlet Flow Control Valve 1*. After the velocity of the water is reduced, the water travels through a weir into the **Separator Tank (8)**. The *Water Inlet Flow Control Valve 1* regulates the flow of water entering the **Inlet Chamber (7)**.

Parallel to the *Water Inlet Flow Control Valve 1* is the venturi **Ozone Injector (6)**, which injects ozone from the **Ozone Generator (5)** into the water returning to the **Wash Water Collection Pit (1)**. The *Ozone Control Valve 6*, regulates the amount of flow returned to the collection pits.

1) Ozone is generated by oxygen molecules passing through a corona discharge **Ozone Generator (5)**. This is an electric charge which causes the oxygen atoms to become ozone molecules. Since ozone molecules are extremely unstable, they only retain their structure for a very short time. For this reason, ozone cannot be stored, but must be continually produced by the **Ozone Generator (5)**.

2) Ozone kills bacteria approximately 3,000 times faster than chlorine.

The non-emulsified oil molecules in the water adhere to the **Oil Coalescing Grid (9)**. When enough oil molecules attach to each other, they form oil droplets. Since oil is lighter than water, the oil floats to the surface. The **Oil Skimmer (10)** is positioned near the top of the **Separator Tank (8)** which allows the thin layer of surface oil and water to drain into the **Waste Oil Decanter (11)**. The oil is then released from the **Waste Oil Decanter (11)** when the *Waste Oil Release Valve 2* is opened. Excess water is returned to the **Wash Water Catch Pit (1)**.

Water remaining in the **Separator Tank (8)** flows into the **Water Level Control Tank (12)**, through another weir, and into the **Holding Tank (13)**. When the **Holding Tank (13)** becomes full, the **Overflow Drain (14)** sends the excess water past **Sensor Probes (15 & 16)** and back into the **Wash Water Catch Pit (1)**. The **Filter Pump (18)** sends the water from the **Holding Tank Outlet (17)** to the *Filter Control Valve 3* which regulates the amount of water going into the filtering system. (Flow is factory set at 20 or 40 gallons per minute, respective to the unit.) A **Flow Meter (19)** is positioned just ahead of the **Multi-Media Filter (20)** to monitor flow. The *Multi-Media Filter Valve 4* has two positions: Filter and Backwash. When in the "Filter" Position, water flows into the **Multi-Media Filter (20)** from the top and passes through several layers of filtering product as it moves toward the bottom. By the time the water reaches the bottom to the filter tank, the contaminants have been filtered down to approximately 20 microns. Laterals are positioned at the bottom of the filter tank, which absorb the filtered water and move it up through the center and out the side of the tank. From there, the water flows into the *Polishing Filter Valve 5*. This valve has two positions: Filter and Backwash. When in the "Filter" position, water flows into the **Polishing Filter (21)** from the top and passes through the activated carbon or filtering agent. As it moves toward the bottom, the activated carbon or filtering agent absorbs odor and contaminants while "polishing" the water. Laterals are positioned at the bottom of the tank, which absorb the water and move it up through the center and out the side of the tank. From there, the water moves to the **Product Tank (22)** where the recycled water is held until usage is required. When needed, water is pulled from the **Product Tank (22)** by the **Transfer Pump (23)** and moved into the **Pressure Tank (24)**. This tank holds water at 30-50 PSI/2.0-3.5 Bar. Water moves directly from this tank to the water discharge outlets upon demand. If water is needed for washing, water is sent to the **Outlet To Pressure Washer (26)**. If the **Wash Water Catch Pit (1)** water level is low, water is added through the **Fresh Water Makeup (28)**. If the **Wash Water Catch Pit (1)** water level is too high, water is sent to the **Rain Water Overflow (25)**. If the recycle timer turns on, water is sent through the **Recycling Solenoid (27)** to the **Wash Water Catch Pit (1)**.

# WLP-20AB FEATURES

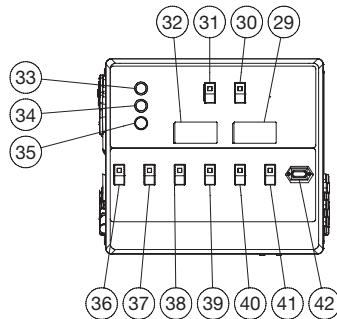
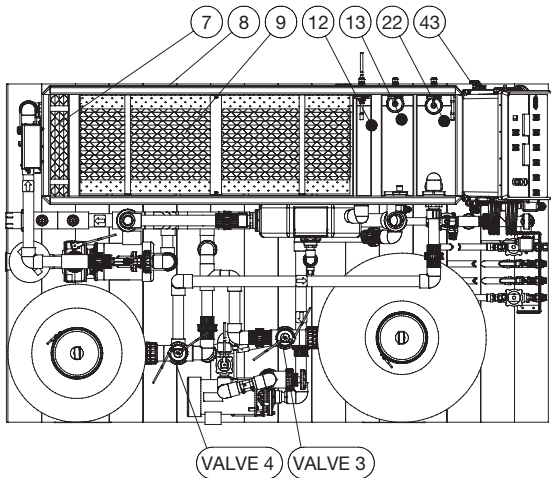
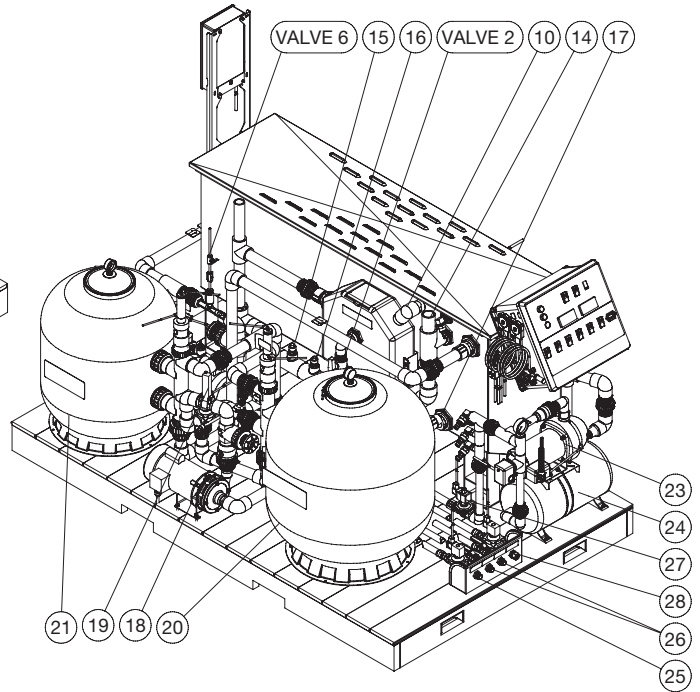
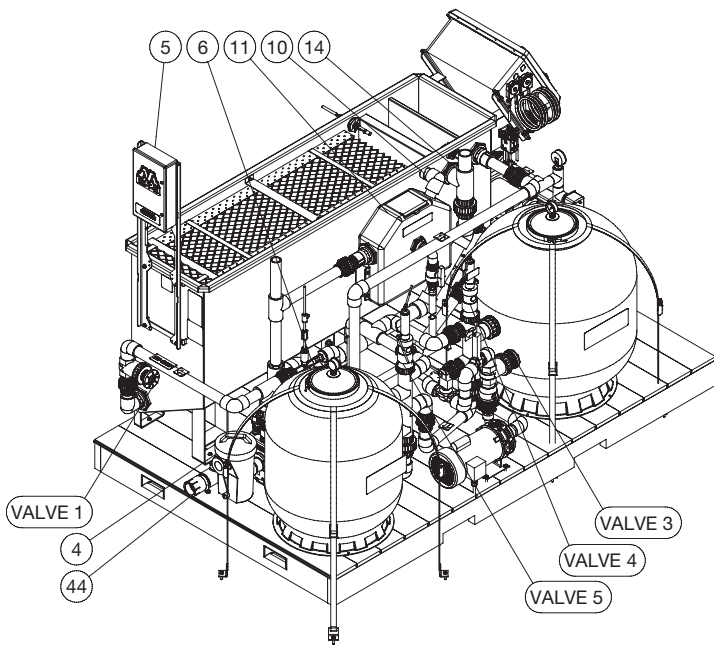

- VALVE 1 WATER INLET FLOW CONTROL VALVE
- VALVE 2 WASTE OIL RELEASE VALVE
- VALVE 3 FILTER CONTROL VALVE
- VALVE 4 MULTI-MEDIA FILTER CONTROL VALVE
- VALVE 5 POLISHING FILTER CONTROL VALVE
- VALVE 6 OZONE CONTROL VALVE

- 1 WASH WATER CATCH PIT (ON PAGE 8)
- 2 3-STAGE COLLECTION PIT (ON PAGE 8)
- 3 SUMP PIT (ON PAGE 8)
- 4 SUMP PUMP
- 5 OZONE GENERATOR
- 6 OZONE INJECTOR
- 7 INLET CHAMBER
- 8 SEPARATOR TANK
- 9 OIL COALESCING GRID
- 10 OIL SKIMMER
- 11 WASTE OIL DECANTER
- 12 CONTROL TANK
- 13 HOLDING TANK
- 14 OVERFLOW DRAIN
- 15 PH SENSOR PROBE

# WLP-40AB FEATURES

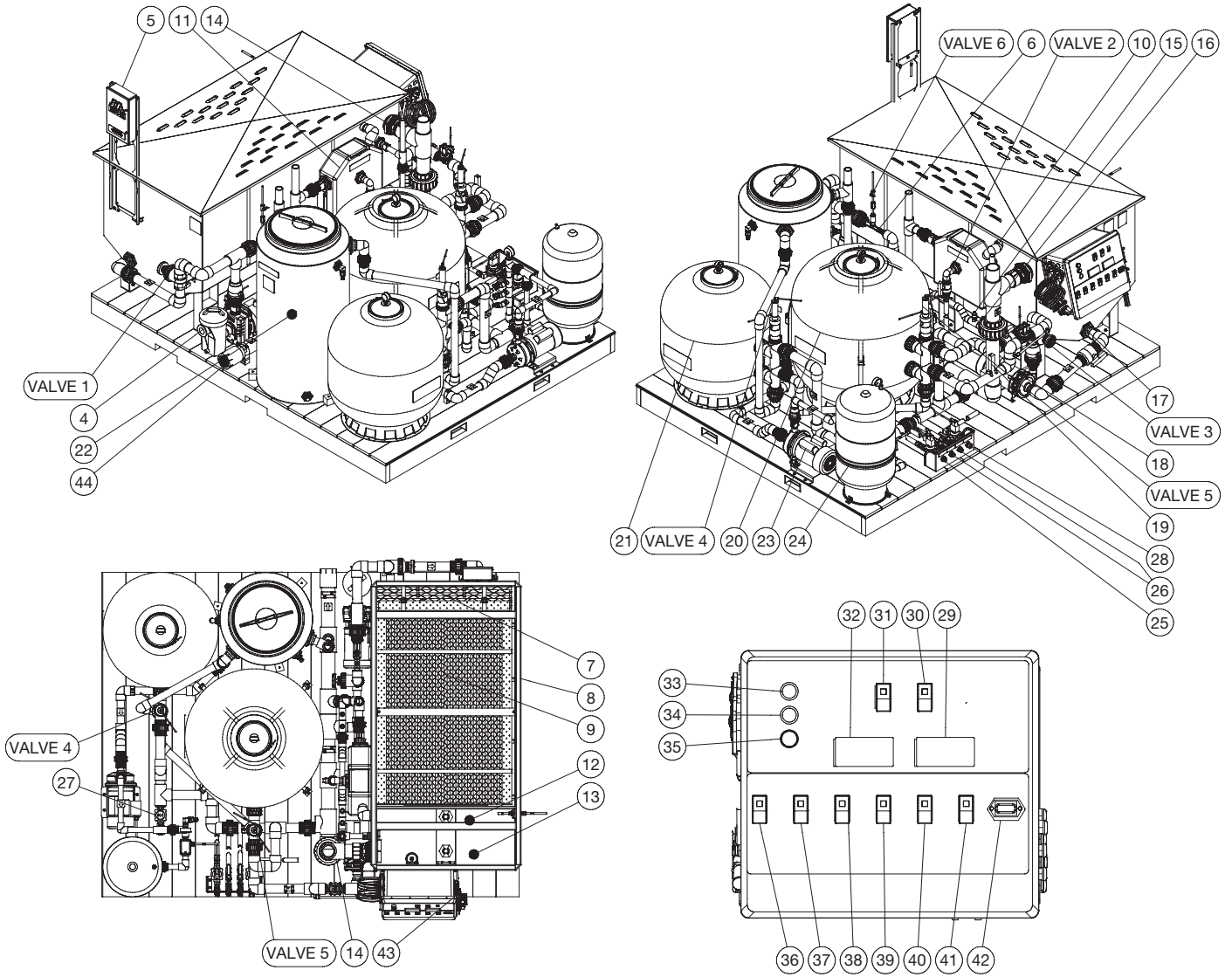

- |    |                           |    |                             |
|----|---------------------------|----|-----------------------------|
| 16 | ORP SENSOR PROBE          | 31 | AUTO-BACKWASH SWITCH        |
| 17 | HOLDING TANK OUTLET       | 32 | PH METER                    |
| 18 | FILTER PUMP               | 33 | POWER ON LIGHT              |
| 19 | FLOW METER                | 34 | BACKWASHING INDICATOR LIGHT |
| 20 | MULTI-MEDIA FILTER        | 35 | BACKWASHING START BUTTON    |
| 21 | POLISHING FILTER          | 36 | SUMP PUMP SWITCH            |
| 22 | PRODUCT TANK              | 37 | FILTER PUMP SWITCH          |
| 23 | TRANSFER PUMP             | 38 | TRANSFER PUMP SWITCH        |
| 24 | PRESSURE TANK             | 39 | PH/ORP METER SWITCH         |
| 25 | RAIN WATER OVERFLOW       | 40 | PH PUMP SWITCH              |
| 26 | OUTLET TO PRESSURE WASHER | 41 | ORP PUMP SWITCH             |
| 27 | RECYCLING SOLENOID        | 42 | HOUR METER                  |
| 28 | FRESH WATER MAKEUP        | 43 | AIR SYSTEM INLET            |
| 29 | ORP METER                 | 44 | OUTLET RETURN TO PIT        |
| 30 | OZONE SWITCH              |    |                             |

# INSTALLATION

**NOTE:** Proper Attire is essential to your safety. It is advised to utilize whatever means necessary to protect eyes, ears, and skin.

1. A Collection Pit System must already be an established structure before installing the WLP-Series water recycling treatment system. A well designed pit system is critical for the proper operation of the recycle system. Consult your dealer for installation requirements.
2. Place the water recycling treatment system platform on a hard, level surface in an area free of flammable vapors, combustible dust, gases or other combustible materials.
3. Set the unit so you have access to all four sides.
4. Do not place unit in an area:
  - a. with insufficient ventilation.
  - b. where environmental hazards (i.e. rain and snow) can come in contact with the water recycling treatment system.
  - c. where the unit may freeze.
5. The water recycling treatment system is shipped with some union connections loosened to protect the unit from shipping damage. Tighten all union connections at this time.
6. Use schedule 80 PVC slip connections.
  - a. Install plumbing from the Sump Pit to the **Sump Pump** using minimum connection sizes of 2".
  - b. Install a check valve in the **Sump Pit**.
  - c. Install plumbing from **Outlet Return To Pit** to the **Wash Water Catch Pit** using a minimum pipe size of 3".
7. Install the three floats in the **Sump Pit**. Allow a 2" tether and enough room for them to move freely without interfering with the plumbing.
  - a. Float #1 Blue: Pit low level shut-off. Attach this float 10" above the inlet.
  - b. Float #5 Red: Fresh water makeup. Height of this float must be adjusted to the individual pit system.
  - c. Float #6 Green: Rain water overflow. Height of this float must be adjusted to the individual pit system.

**NOTE:** The above information is for reference only. Professional installers or architects may use this guideline to meet specific site requirements.

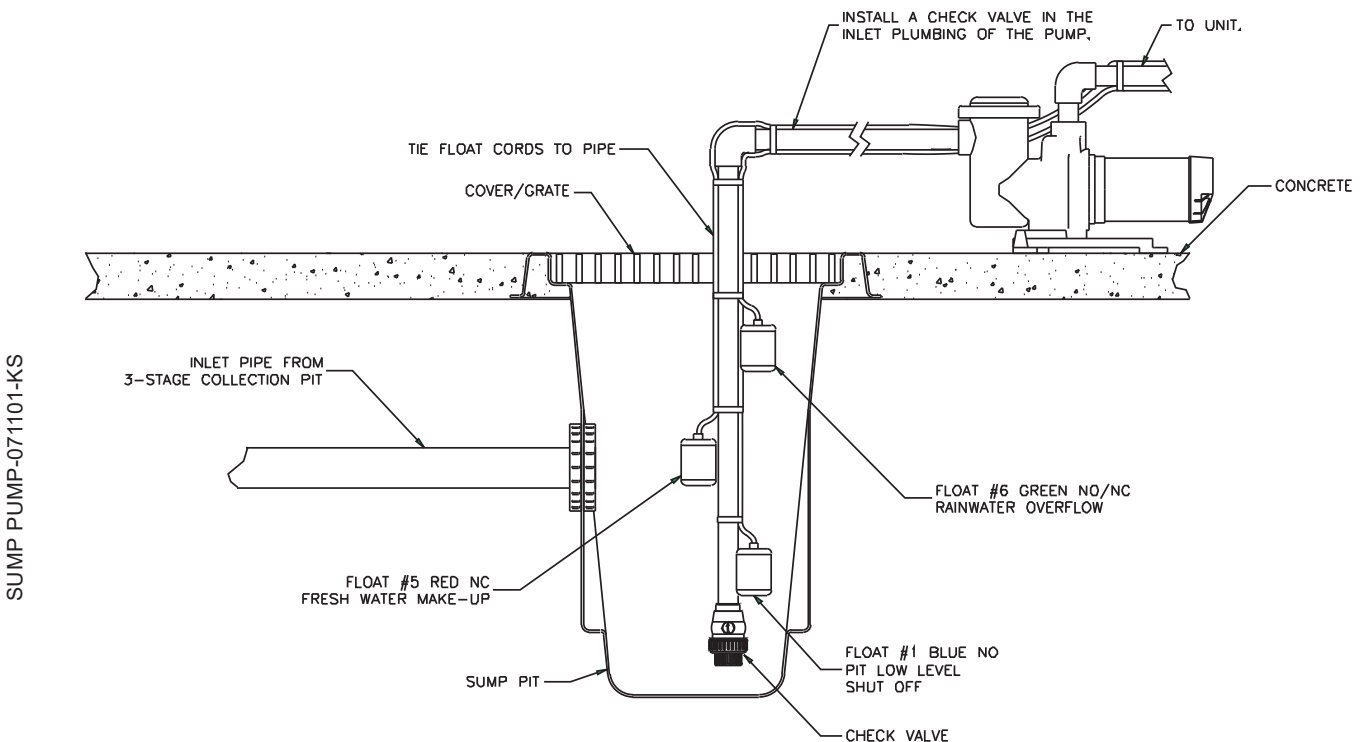

# INSTALLATION



**WARNING**  
**RISK OF ELECTROCUTION!**  
**TO REDUCE THE RISK OF ELECTROCUTION,**  
**KEEP ALL CONNECTIONS DRY AND OFF THE GROUND.**

8. A qualified electrician must hook up the electrical system.
  - a. Verify the electrical supply at the power source is off.
  - b. Be certain all switches on the **Control Panel** are in the "OFF" position.
  - c. Run water tight conduit or cord from the **Sump Pump** and Floats to the **Control Panel** (standard unit will come with sump pump wired in already).
  - d. Run water tight conduit from the local disconnect to the **Control Panel**.
  - e. The electrician will need to drill holes in the **Control Panel** for the conduit and/or cord(s).
  - f. Make connections to the terminal strips as shown below.

FIELD WIRING DIAGRAM - WLP-20AB, 40AB-0M11\_0M31 100919 MLK

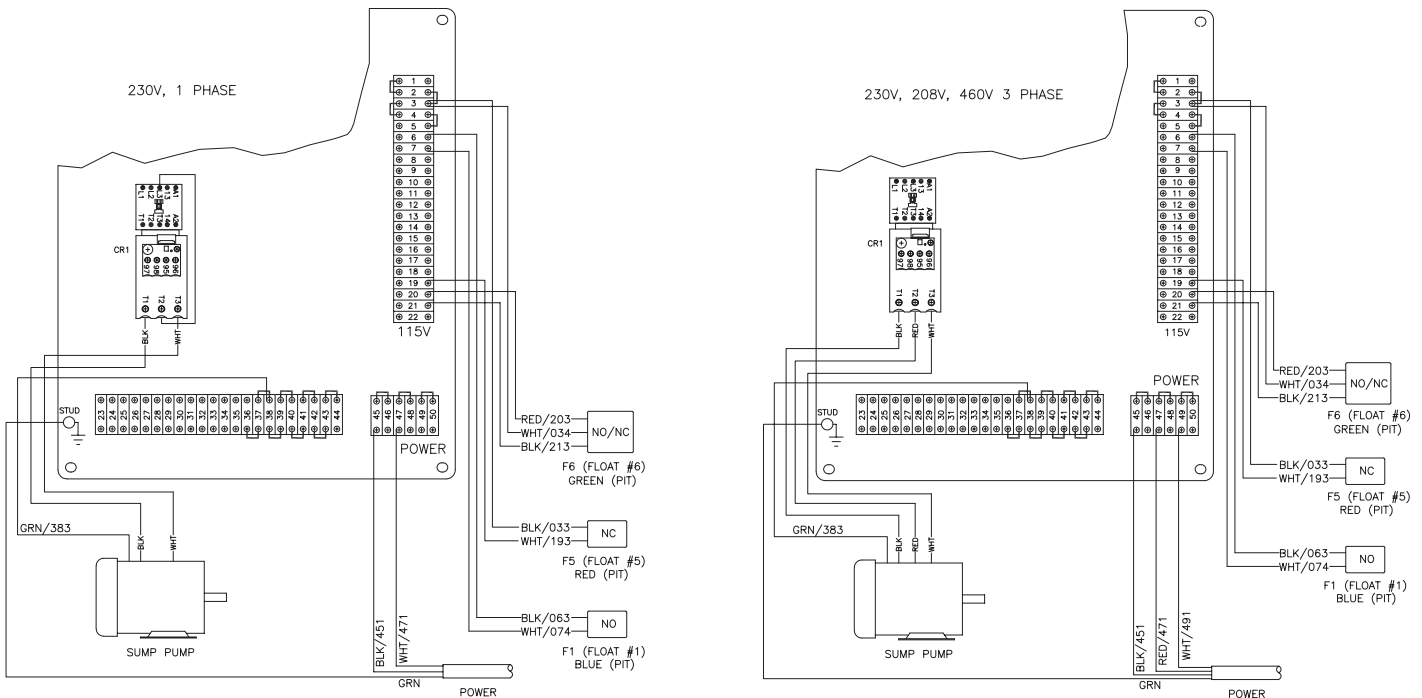

9. Make the following hose connections:
  - a. From a pressurized water supply to the **Fresh Water Makeup**.
  - b. From the **Outlet to Pressure Washer** to the pressure washer.
  - c. From the **Rain Water Overflow** to a storage tank for further processing or disposal. **DO NOT SEND THIS WATER BACK TO THE WASH WATER CATCH PIT!**
  - d. From a pressurized air supply to the **Air System Inlet**, turn regulator until gauge reads 50 to 80PSI.

**NOTE:** In most cases, you must have a permit to legally dispose discharged water.

# STOP

**TO ENSURE YOUR WATER RECYCLE TREATMENT SYSTEM OPERATES SAFELY AND EFFICIENTLY, COMPLETE THE PRE-OPERATION CHECKLIST BEFORE PROCEEDING.**

## PRE-OPERATION CHECKLIST

Before proceeding, answer all the questions on this checklist.	YES	NO
<b>CODES:</b>		
1. Does the electrical wiring meet all codes? _____		
2. Does plumbing meet all codes? _____		
<b>LOCATION:</b>		
1. Is the unit located on a hard level surface free of flammable vapors, combustible dust, gases or other combustibles? _____		
2. Is the unit located in a large ventilated area? _____		
<b>ELECTRICAL:</b>		
1. Is the unit properly grounded? _____		
2. Does the power supply, voltage and amperage match the data plate? _____		
<b>PLUMBING:</b>		
1. Is the plumbing sized correctly? _____		
2. Is the check valve installed before the <b>Sump Pump</b> ? _____		
3. Are all plumbing connections secured? _____		
4. Are all hose connections secured? _____		
<b>GENERAL:</b>		
1. Have all operators using this unit read and understood this entire manual? _____		
2. Has the unit been installed by qualified service people who followed the instructions listed in this manual? _____		

**NOTE: IF "NO" WAS MARKED TO ANY OF THESE QUESTIONS, CORRECT THE SITUATION BEFORE OPERATING.**

# PREPARATION

## PRESTART PROCEDURES:

1. Position the valves on the WLP water recycling treatment system in the "Start-up Mode".
  - Water Inlet Flow Control Valve: Turn valve one rotation short of completely closed.
  - Filter Control Valve: Turn valve one rotation short of completely closed.
  - Oil Release Valve: Turn valve completely closed.
2. Be certain all hoses are securely connected.
3. Be certain the incoming air tube to the **Ozone Generator** is not obstructed.
4. Be certain all switches on the **Control Panel** and **Ozone Generator** are in the "OFF" position.
5. Turn on the power supply. The **Power Indicator Light** should glow.

## START-UP:

---

1. Ensure water supply to the **Fresh Water Makeup** is turned on and pit is filled with water. If the pit is not full, water will fill the **Holding Tank** and overflow through the **Overflow Drain** and back to the **Sump Pit**.
2. To prime the **Sump Pump**, remove the lid over the **Basket Strainer** and fill the **Basket Strainer** and the plumbing from **Sump Pit** to the **Sump Pump** with water, then replace the lid.
3. Turn on the **Sump Pump Switch**; water will flow into the **Oil/Water/Solids Separator**.
4. Flow can be increased by opening the Water Inlet Flow Control Valve on the **Oil/Water/Solids Separator**.
5. As the water fills the **Holding Tank**, it will begin to flow out the **Overflow Drain** at the top of the tank. At this point, flow can be adjusted with the Water Inlet Flow Control Valve. Set the flow rate to 20 or 40GPM. If the finger switch rises and turns off the **Sump Pump**, reduce the flow rate with the Water Inlet Flow Control Valve.
6. Turn on the **Ozone System Switch** located on the **Control Box**. The ozone system is working properly when air bubbles and ozone smell are noticed in the return to pit line. If no air bubbles are observed, turn off the **Ozone System Switch**. Verify that all ozone generator tubes are connected properly, and that the Mazzei Venturi injector is installed properly. (The Ozone Flow Control Valve is set at the factory and should not need adjusting.) The **Ozone Generator Switch** can now be turned on. A green light will turn on on the outside of the Ozone Generator.
7. Turn on the **Filter Pump Switch**. The **Filter Pump** will automatically turn off when the **Product Tank** is full of water.
8. As water flows to the filters, use the Filter Control Valve to adjust the water flow to the 20 or 40GPM. Check the **Filter Flowmeter** located ahead of the **Multi-Media Filter**.
9. Water will begin to flow from the **Multi-Media Filter** to the **Polishing Filter**. As water flows through the **Multi-Media Filter**, air will automatically bleed from the **Multi-Media Filter** to the **Polishing Filter**.
10. As water flows through the **Polishing Filter**, air will also automatically bleed from the **Polishing Filter** to the **Product Tank**.

**NOTE:** DO NOT attempt to backwash the filters until all of the air is bled from the system.

11. When the **Product Tank** is full and the **Filter Pump** turns off, prime the **Transfer Pump** by opening the **Outlet to Pressure Washer** valve until water exits.
12. Turn on the **Transfer Pump Switch** to allow water to flow into the **Pressure Tank**. The **Transfer Pump** will run until the pressure system reaches 50PSI. This can take up to 7 minutes.
13. Water is now completely cycled in the system.

# PREPARATION

## pH AND ORP CONTROL SYSTEM:

Proper pH and ORP levels must be maintained in the pit to prevent growth of bacteria, algae, odors, etc. Water must be chemically balanced to effectively recycle. The effectiveness of ORP chemical in the water depends on the pH level.

-The optimum pH level to add ORP chemical is 6.5 - 6.8.

-As the pH level rises to 7.5, about 5% more ORP chemical must be added to achieve the same ORP reading.

-At a pH level of 8.0 and above, a large amount of ORP chemical must be added to increase the ORP reading.

As excess water leaves the holding tank it moves past the **pH and ORP Sensors** before returning to the **Sump Pit**. The **Sensor Probes** analyze the pH and ORP levels in the water.

- a. **pH Sensor Probe.** This probe analyzes the pH (acidity & alkalinity) in the water. If the water is too acidic (low pH) the acid will breakdown the iron present in the water to a liquid form, thus causing rusty looking water in the system. If the water is too alkaline (high pH) the bacteria killing potential of the ORP agent will be drastically lowered.

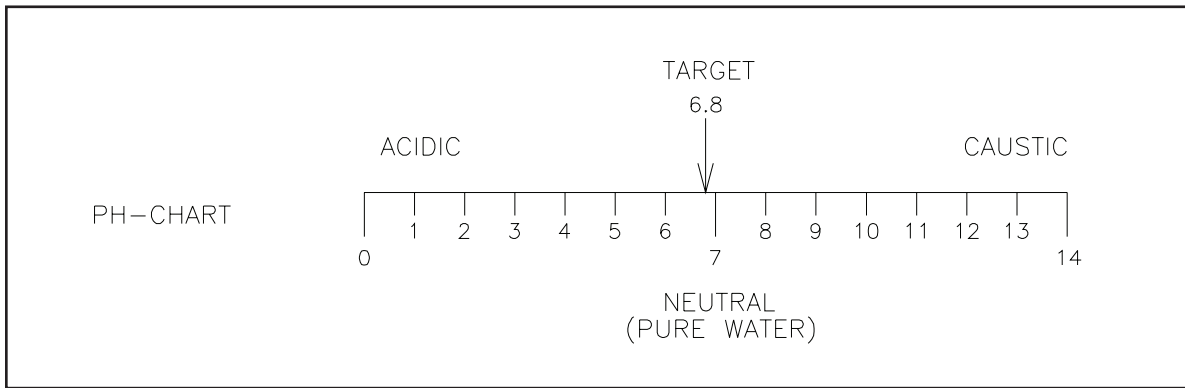

WLP-0008-112098-JJ

- b. **ORP Sensor Probe.** This probe analyzes the Oxidation Reduction Potential (ORP). This reading states amount of bacteria killing agent in the water.

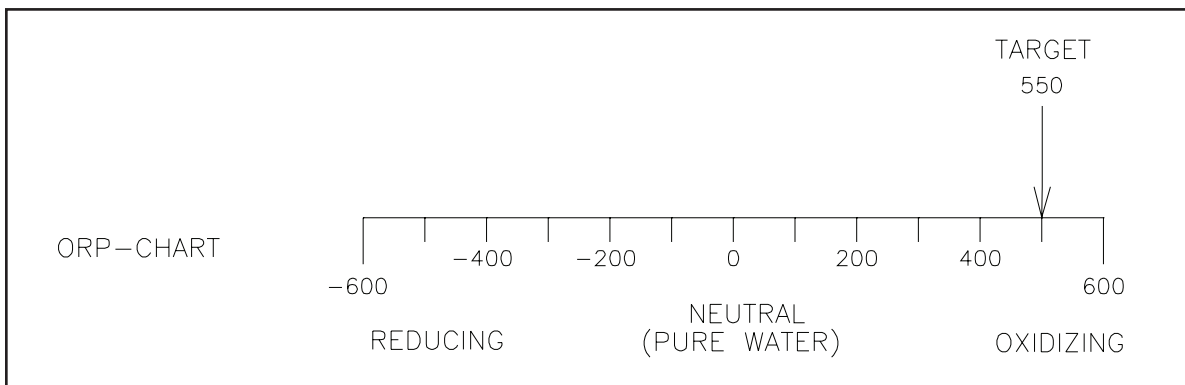

WLP-0009-112098-JJ

The probes analyze the pH and ORP levels of the water and display the readings on the digital **pH and ORP Meters**.



# PREPARATION

## INSTALLATION OF pH AND ORP PROBES:

### **CAUTION**

#### **RISK OF PROBE DAMAGE!**

- DO NOT ALLOW PROBES TO BE EXPOSED TO AIR. ONCE PROBES ARE IN PLACE, TURN WATER ON IMMEDIATELY.
- HANDLE PROBES CAREFULLY AS THEY ARE MADE OF GLASS.
- DO NOT ALLOW PROBES TO BE EXPOSED TO FREEZING ENVIRONMENTS. KEEP THE ORIGINAL CONTAINERS IN WHICH THE PROBES WERE SHIPPED. THEY WILL BE NEEDED FOR PROBE STORAGE DURING WINTERIZING.

### pH SENSOR PROBE

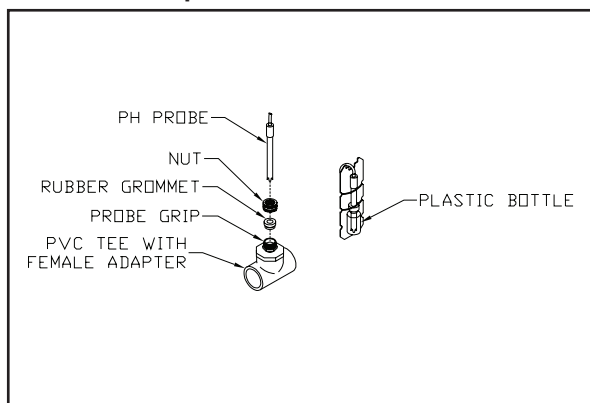

### ORP SENSOR PROBE

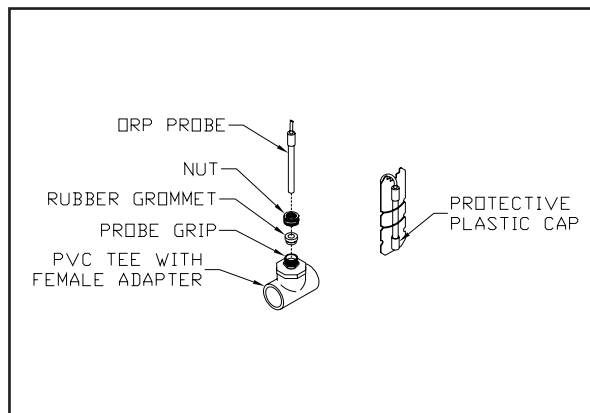

1. Turn off the Sump Pump Switch and ensure no water is being discharged.
2. Locate the probe grips at the sensor probes and unscrew the nut from one of the grips.
3. Remove one of the probes (pH or ORP) from its storage container. (Be certain to save the container for probe storage during winterizing.)
4. Carefully slide the probe grip nut over the glass probe.
5. Gently push the probe through the probe grip approximately 2 inches and tighten the nut onto the probe grip.
6. Repeat process for the remaining probe.
7. Connect BNC adapter at the end of each probe to the corresponding adapter labeled at the bottom of the control box. Yellow probe = ORP. Blue probe = pH.
8. Turn on the Sump Pump Switch, and the pH/ORP Meters Switch.

**THE PROBES CANNOT BE ALLOWED TO DRY OUT.**

# INSTALLATION

## PH CONTROLLER PROGRAMMING

pH controller will come programmed and on measure mode with the following parameters set.

Measure Mode: pH

- **Temperature Compensation:** 03 MAN (No use of a temperature probe, manually can adjust temperature but this is normally is not required as long as temperature is in the 60°F-80° it has a small effect on pH reading.)
- **Manual temperature set at 70°F.**
- **7.00 Buffer and 4.01 Buffer:** Controller is calibrated on STAND using a 7 pH buffer solution or calibrator, then a 4.00 buffer calibrator for SLOPE. This will never need to be changed.
- **pH relay 1 selected for HI1:** Relay 1 will be closed if the probe reads HIGH over the set point (+ 1/2) the hysteresis. This relay will turn on the chemical pump, low pH chemical to be used to lower pH. Relay 1 can be changed to LOW1 to work in the opposite direction; if probe reads below set point the chemical pump will turn on to add high pH chemical.
- **Set point 1 is 7.00:** pH point at which (+,-) half the hysteresis, the relays will close to turn on chemical pump.
- **Hysteresis is at 0.20:** The range around the set point that the relays will turn on and off. At a set point of 7.00, the relay will close between 7.10 and 6.90.
- Set point 2, Relay 2 and Hysteresis 2 is not used for pH controller.

For ORP controllers will come programmed and on measure mode with the following parameters set.

## ORP CONTROLLER PROGRAMMING:

*ORP controllers will come programmed and on measure mode with the following parameters set.*

### MEASURE MODE: ORP RMV

- **Temperature Compensation:** 03 MAN (No use of a temperature probe) does not affect ORP reading.
- **Manual temperature set at 70°F.**
- **7.00 Buffer and 4.01 Buffer:** Controller is calibrated on STAND using a 7 pH buffer solution or calibrator, then a 4.00 buffer calibrator for SLOPE. This will never need to be changed.
- **Relay 1:** Set for ORP RMV
- **ORP relay 1 selected for LOW1:** Relay 1 will be closed if the probe reads LOW under the set point (- 1/2) the hysteresis. This relay will turn on the ORP chemical pump.
- **Set point 1 is 350rmv:** ORP point at which (+,-) half the hysteresis, the relays will close to turn on chemical pump.
- **Hysteresis is at P10.0:** The range around the set point that the relays will turn on and off. At a set point of 350mv, the relay will close between 345mv and 355mv.
- Relay 2 is not used for ORP controller.

## FRONT PANEL

The front panel consists of a 4-digit LCD display and 4 keys.

### 1. [ MODE ] key:

- 1a. In the Measure mode, this key will switch the display in sequence from pH, Temperature, ORP absolute mV, ORP relative mV and back to pH again.
- 1b. In the Calibration/Setting mode, pressing this key for three seconds will move you back to the previous parameter in the case when recalibration / resetting is required.

### 2. [ UP ] key:

- 2a. In the Calibration mode, pressing this key will show the next possible option. In the Setting mode, pressing this key will show the next possible option and increases the numeral increment.
- 2b. In the Measure mode, pressing this key and [ENTER] key at the same time, the unit will enter the Calibration mode.

### 3. [ DOWN ] key:

- 3a. In the Calibration mode, pressing this key will show the next possible option. In the Setting mode, pressing this key will show the next possible option and decreases the numeral increment.
- 3b. In the Measure mode, pressing this key and [ENTER] key at the same time, the unit will enter the Setting mode.

### 4. [ ENTER ] key:

In any mode where the user can change the settings, pressing this key will save the new settings. If no change has been made then pressing this key will just move the user to the next setting.

# INSTALLATION

## LCD SCREEN

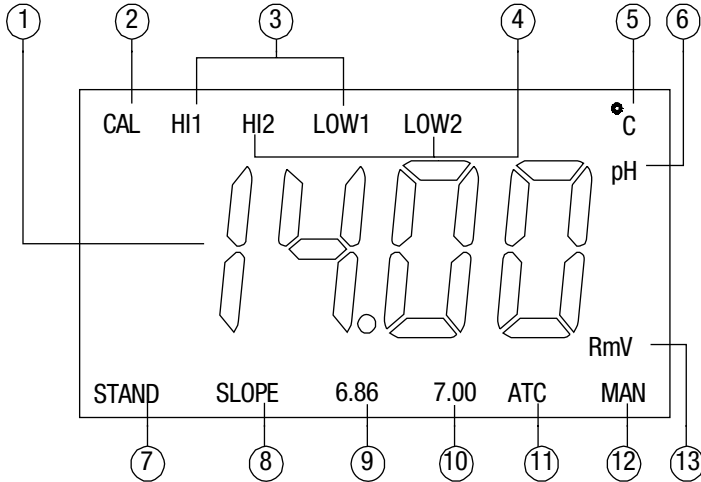

1. Major LCD display.
2. **CAL** – This icon will be displayed if the meter is in the Calibration/Setting mode.
3. **HI1 & LOW1** – These icons, when displayed, indicate relay action and relay number.
4. **HI2 & LOW2** – These icons, when displayed, indicate relay action and relay number.
5. **°C** – Temperature and unit display.
6. **pH** – Unit indicator.
7. **STAND** – This icon will blink before Buffer 1 calibration. The icon will stay on while Buffer 1 is being calibrated.
8. **SLOPE** – This icon will blink before Buffer 2 calibration. The icon will stay on while Buffer 2 is being calibrated.
9. **6.86** – The 6.86 buffer group: 6.86, 4.00, 9.18.
10. **7.00** – The 7.00 buffer group: 7.00, 4.01, 10.01.
11. **ATC** – This icon will be displayed when a temperature probe is connected.
12. **MAN** – This icon will be displayed when a temperature probe is not connected.
13. **RmV** – Unit indicator.

## MEASURE MODE

Turning on the unit will always display the **Measure mode**. This instrument is designed to provide 4 distinct measurements:

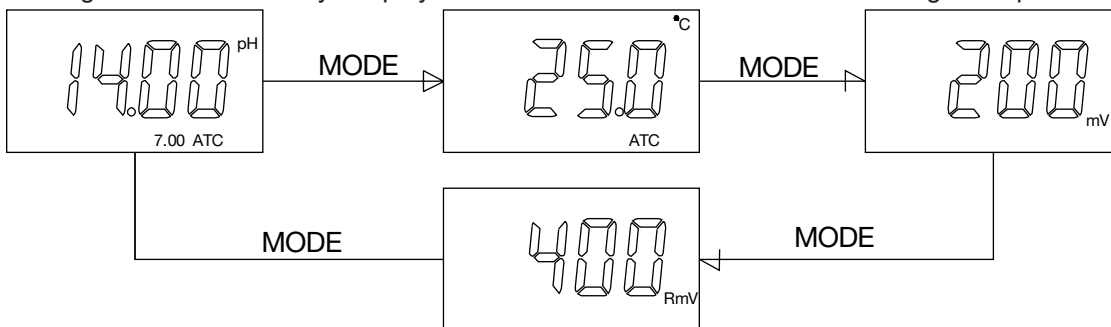

1. **pH** – The degree of acidity or alkalinity of the solution.
2. **Temperature** – Current temperature of the solution.
3. **ORP mV** – A measurement of absolute ORP mV.
4. **ORP RmV** – A measurement of relative ORP mV. The offset value at the RmV calibration will be added to the ORP absolute value to display the ORP relative value.

*Note: ORP relative value range: ORP absolute value - 1000mV to ORP absolute value + 1000mV Pressing [MODE] key in the **Measure mode** will cycle the display from the four modes above.*

# INSTALLATION

## SETTINGS MODE

Pressing **[DOWN]** key and **[ENTER]** key at the same time, the meter will enter into the Setting mode.

1. Temperature compensation select:

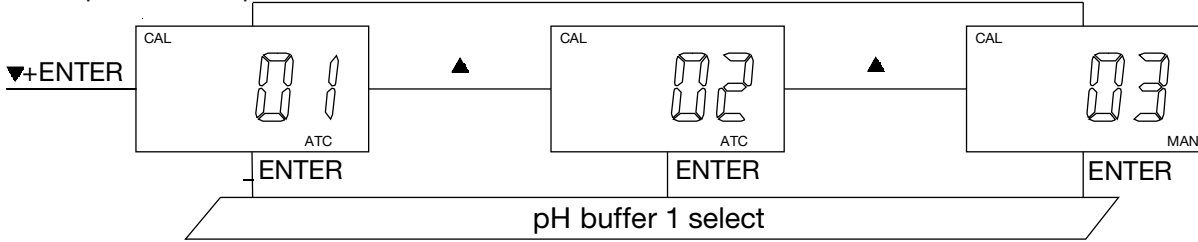

Pressing **[UP]** key or **[DOWN]** key in this screen will cycle the display from 01 (Thermistor: 10k ohm), 02 (Resistor: PT1000), 03 (Manual) modes above.

Select the preferred temperature compensation mode, press **[ENTER]** key to save, and enter the next setting screen.

### PH BUFFER 1 SELECT:

Pressing **[UP]** key or **[DOWN]** key in this screen will cycle the display from 7.00, 6.86 buffer above.

Select the preferred buffer, press **[ENTER]** key to save, and enter the next setting screen.

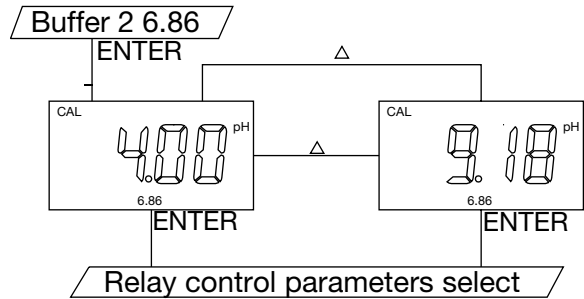
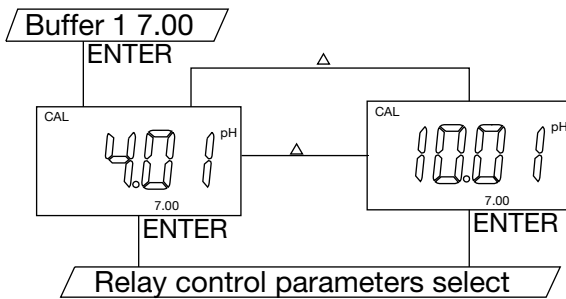
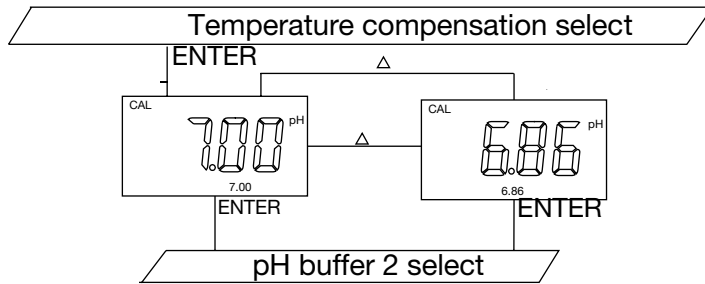

Pressing **[UP]** key or **[DOWN]** key in this screen will cycle the display from 4.01, 10.01 (or 4.00, 9.18) buffer above. Select the preferred buffer, press **[ENTER]** key to save, and enter the next setting screen.

*Note: The pH buffer 2 is either 4.01 or 10.01 if select 7.00 buffer at pH buffer 1 select screen. The pH buffer 2 is either 4.00 or 9.18 if select 6.86 buffer at pH buffer 1 select screen.*

# INSTALLATION

## RELAY CONTROL PARAMETERS SELECT:

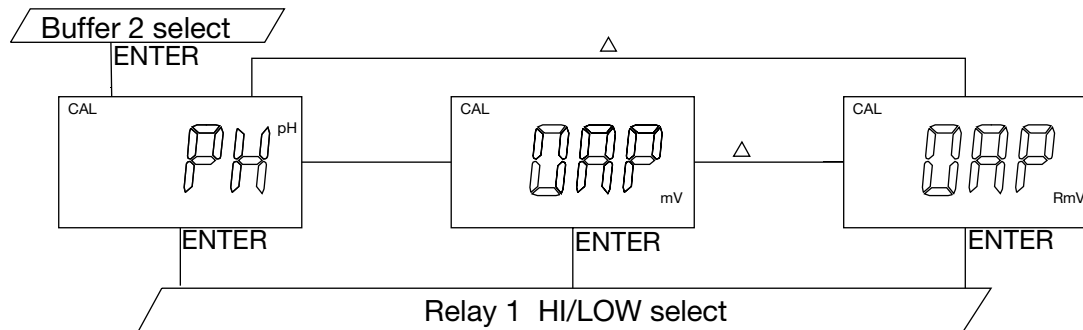

Pressing **[UP]** key or **[DOWN]** key in this screen will cycle the display from pH, ORP mV ORP RmV modes above. Select the preferred mode, press **[ENTER]** key to save, and enter the next setting screen.

*Note: The relay will work with the choice of parameters.*

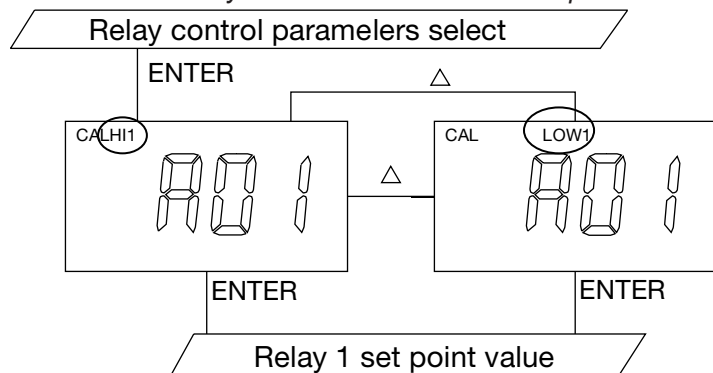

Pressing **[UP]** key or **[DOWN]** key in this screen will cycle the display from HI, LOW modes above. Select the preferred mode, press **[ENTER]** key to save, and enter the next setting screen.

*Note: See "Controlling the relays" page.*

Relay 1 set point value:

Pressing **[UP]** key or **[DOWN]** key in this screen to adjust the value, press **[ENTER]** key to save, and enter the next setting screen.

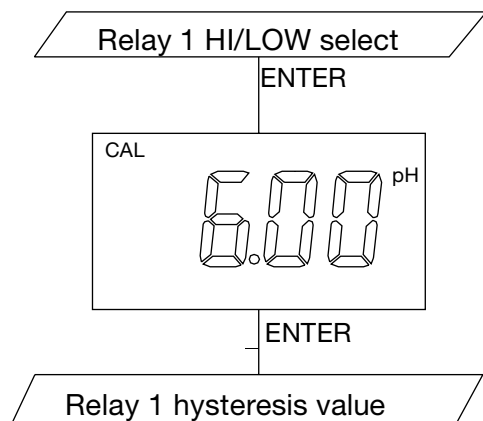

# INSTALLATION

Relay 1 hysteresis value:

Pressing [UP] key or [DOWN] key in this screen to adjust the value, press [ENTER] key to save, and enter the next setting screen.

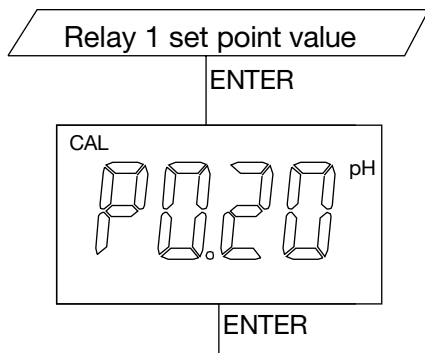

## Relay 2 HI/LOW select

Relay 2 High / Low select: Same as “Relay 1 work way select”

Relay 2 set point value: Same as “Relay 1 set point value”

Relay 2 hysteresis value: Same as “Relay 1 hysteresis value”

## PH CALIBRATION MODE

The TX20 uses 2-point calibration for pH. The first point must be 6.86/7.00, and the second point can either be 4.00/4.01 or 9.18/ 10.01.

In the pH Measure mode, pressing [UP] key and [ENTER] key at the same time to allow the meter to go to the pH Calibration mode.

## CONTROLLING THE RELAYS

### 1. ISOLATION VOLTAGE:

The maximum isolation voltage of the relay output contacts is 1500 VDC. The voltage differential between the relay output contacts and the load should not exceed 1500 VDC.

### 2. OUTPUT LOAD:

The current through the relay output contacts should not exceed 5 Amp at 115 VAC and 2.5 Amp at 230 VAC in order not to cause permanent damage to the relay contacts. This rating is specified for resistive loads only.

### 3. RELAY ACTION, RELAY SET POINT AND HYSTERESIS VALUE:

Relay Action	Effective RELAY-ON Set Point	Effective RELAY-OFF Set Point
HI	S.P. + (1/2 H.V)	S.P. – (1/2 H.V)
LOW	S.P. – (1/2 H.V)	S.P. + (1/2 H.V.)

If the relay action is set to **HIGH**, the relay will turn **ON** at (Set Point +1/2 Hysteresis ), and will turn **OFF** at (Set Point -1/2 Hysteresis ).

If the relay action is set to **LOW**, the relay will turn **ON** at (Set Point -1/2 Hysteresis ), and will turn **OFF** at (Set Point +1/2 Hysteresis ).

There are two Independent relays the user can bind to the **pH**, **ABSOLUTE mV** or **RELATIVE mV mode**. The user can only bind the two relays to one reading mode at a time. The user can change this anytime by changing option at the **setting mode**.

*Note:*

1. The ideal set point range for pH is 0.00 to 16.00 pH.
2. The ideal set point range for absolute mV is –2000 to 2000 mV.
3. The ideal set point range of for relative mV is -3000 to 3000 mV.

# OPERATION

## OPERATION:

At this point the PH and ORP control system is ready for operation. The system will now read the PH and ORP of the water and the metering pump will activate when the PH or ORP is out of the range of the desired set point.

*NOTE: If the metering pump is activated but the rollers fail to spin, the rollers of the pump might be stuck. You should be able to manually spin the roller by hand to get these started. Add lubricant to the rollers if the problem persists.*

## FINAL pH AND ORP SYSTEM SETUP:

1. Place the hoses from the **pH and ORP Pumps** into the **Adjustment Chemicals**.
  - a. The recommended pH chemical for this system is aluminum sulfate.
  - b. The recommended ORP chemical for this system is bleach or sodium hypochlorite at 5%.
2. Turn on the **pH and ORP Pump Switches**. Chemicals will be inserted into the water as necessary.

## PREPERATION

### SETTING THE TIMERS:



**WARNING**  
**RISK OF ELECTROCUTION!**  
**MAKE SURE ALL POWER TO THE UNIT IS TURNED OFF WHEN WORKING ON COMPONENTS IN THE CONTROL PANEL.**

A time switch is used to operate the water recycling system and the auto-backwash system. This timer has been pre-set at the factory.

#### TIME SWITCH:

The time switch is used as a dual functioning timer. The first function (C1) is set to activate the auto-backwash system once a day at 9 PM. Secondly, the time switch is used to activate the water recycling system (C2) once a day at 2 AM. If the water in the recycle system lies dormant for more than six hours, it tends to become stagnant and odorous. Dependant on use, you may need to add one or two more daily cycles to this timer program

When setting the time switch, a program must be entered for both the turn on time and the turn off time. Each on cycle and off cycle count as one program. There are 42 programs available on this time switch. FOR COMPLETE PROGRAMMING INSTRUCTIONS FOR THE TIME SWITCH, PLEASE REFER TO THE MANUFACTURERS MANUAL on the following pages.

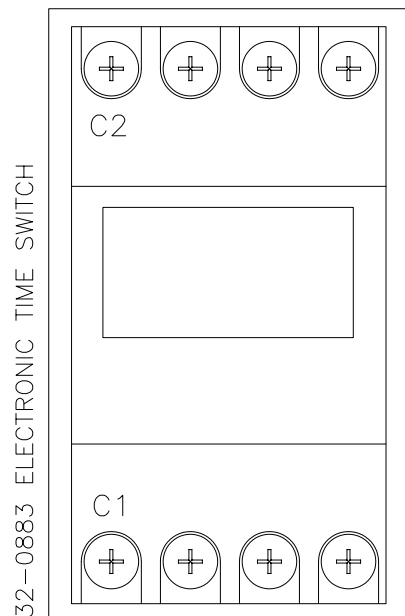



# PREPARATION

## PROGRAMMING INSTRUCTIONS FOR THE TIME SWITCH:

**TR 612 top**  
**TERMINA**  
 2-channel 7 day timers

*According to version  
 preprogrammed  
 with the current time  
 and summer/winter  
 norm time*

**Safety Information**

The connection and installation of electrical appliances must be performed by a skilled electrician only. Any intervention into or modifications to the appliance shall lead to the lapse of all warranty rights. Comply with your national regulations and all relevant safety stipulations.

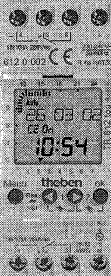
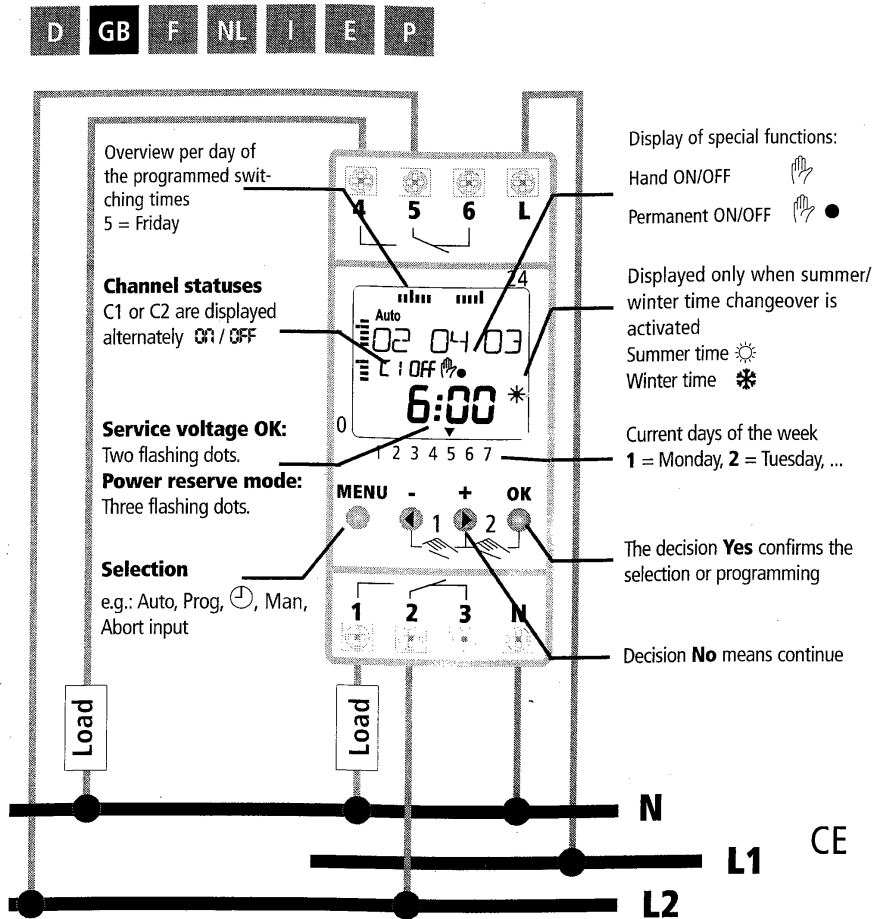
# PREPARATION

## First contact

### Info

The timer is delivered in so-called sleep mode. To increase the power reserve the switch clock changes to the sleep mode after approx. 15 minutes.

#### To activate without a service voltage

Briefly press the **MENU** key.

#### Activate with mains voltage

If the timeswitch is already pre-programmed with the actual time, the weekday, and the changeover setting for Summer / Winter time, the actual time and status display appears after selection of the national language.

#### If the timer is not pre-programmed

First select your national language and then enter the actual date and time.

#### Activate the clock, select the national language

By pressing the  $\oplus$  or  $\ominus$  key select your national language.

Store your selection by pressing the **OK** key.

#### For programming, viewing or deleting

First of all read the text display.

#### Menu selection

Select by pressing the **MENU** Prog key.

Confirm by pressing **OK**.

By pressing the  $\oplus$  key select the desired menu.

e.g. **New, View or Delete**.

Confirm your selection by pressing **OK**.

**Set or change:** by pressing  $\oplus$  or  $\ominus$ .

Store by pressing **OK**.

#### To display the switching times:

In the menu View, press the **OK** key several times.

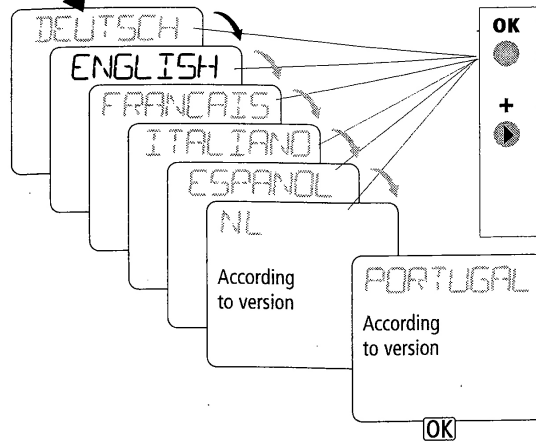
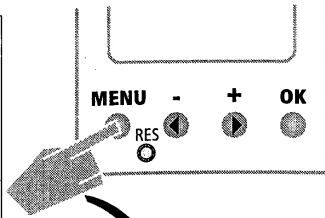

**OK** The decision **Yes**, confirms the selection or programming.

**+** The decision **No**, means continue.

Set or amend by pressing the  $\oplus$  or  $\ominus$  keys.

**RESET** (only in case of emergency): If you perform a RESET of the timer, the individual settings will be deleted. The programmes switching times remain intact. Press the **RES** key with a pointed object for approx. 1 second.

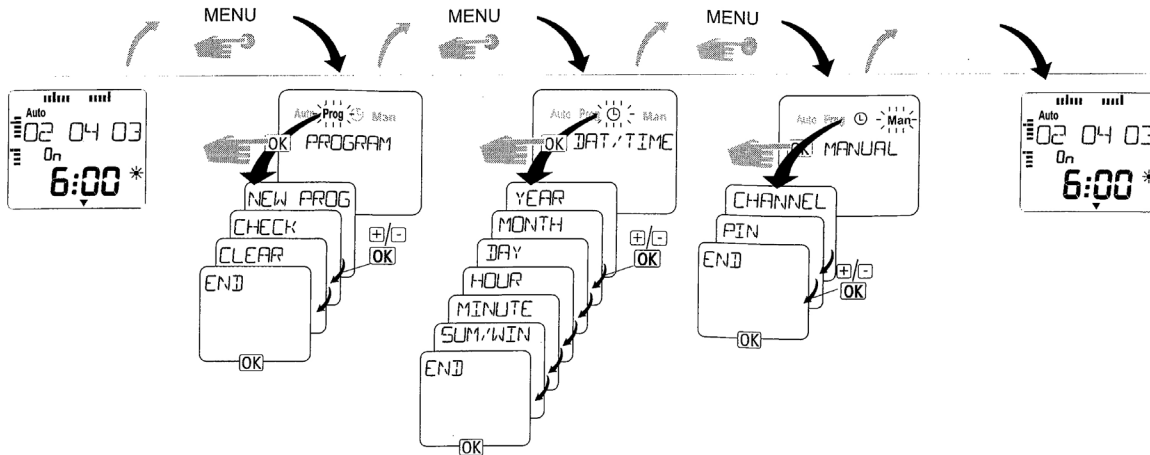

### Technical data

<b>TR 612 0 xxx</b> 230V~ +/- 10% 50-60 Hz 240V~ +6%-14% 50-60 Hz	<b>2x16(10)A</b> 250 V~ min. 100 mA 24V AC/DC	Degree of protection II EN 60730 IP 20 EN 60529	2300W	9 x 7 W 7 x 11 W 7 x 15 W 7 x 20 W 7 x 23 W	400W (42µF) 
<b>TR 612 1 xxx</b> 120V~ +/- 10% 50-60 Hz	Type 1 BSTU IEC/EN 60730-2-7	<b>42</b> memory locations		2300W	1000 W

# PREPARATION

## Programming the switching time

### Formation of day groups

If the same switching times are active on several days of the week, they occupy just **one** memory location, e.g. Monday – Friday 7.30 hrs ON.  
**42** memory locations are available.

### Group formation

In answer to the text question **Copy**, decide by pressing the **OK** key that the day program should be copied to another day of the week.

Switching times for lighting systems, machines, ventilation systems, alarm systems etc.

### Example

**Example:** Switching on the lighting of a sports hall on Mon., Tues., Thurs., Fri. from 7.30h until 12h.

#### Programming example

Select **PROG** by pressing the **MENU** key.  
 Store your selection by pressing the **OK** key.  
 Select **NEW** by pressing the **+** or **-**.  
 Store your selection by pressing the **OK** key.  
 Select **channel C1 or C2** by pressing **+** or **-**.  
 Store your selection by pressing **OK**.  
 Select **ON** by pressing **+** or **-**.  
 Store your selection by pressing **OK**.  
 Set the hours and minutes by pressing the **+** or **-** key.  
 Store selection by pressing **OK**.

#### To store this day of the week only

Select weekday by pressing **+** or **-**.  
 Select **STORE** by pressing **+**.  
 Store by pressing **OK**.

#### To copy to other days of the week

Store **COPY** by pressing **OK**.  
 Select weekday by pressing **+** or **-**.  
 Store by pressing **OK**.  
 To leave out a day of the week, skip by pressing the **+** key.  
 Finally select the **STORE** display by pressing **+**.  
 Store your selection by pressing **OK**.

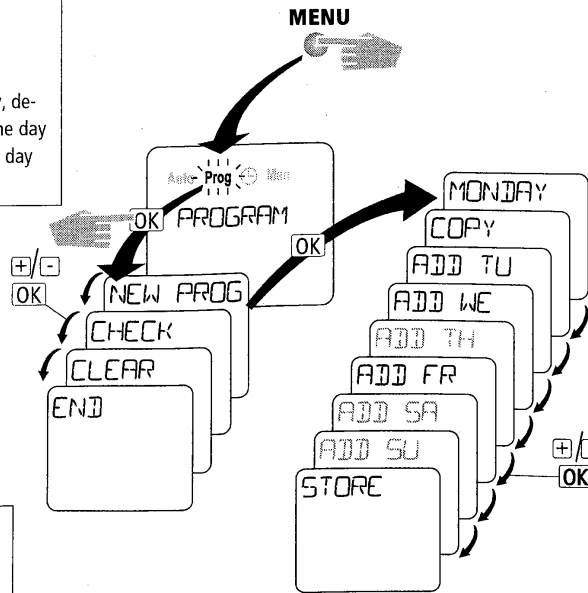

When programming an ON and OFF switching time, e.g. Monday 9 AM, a switch-off at 9 AM always has priority.

### Program review

Following programming the timer makes a program review back to midnight and then sets the correct switching status.

## Override Permanent ON or OFF

### Individual deletions

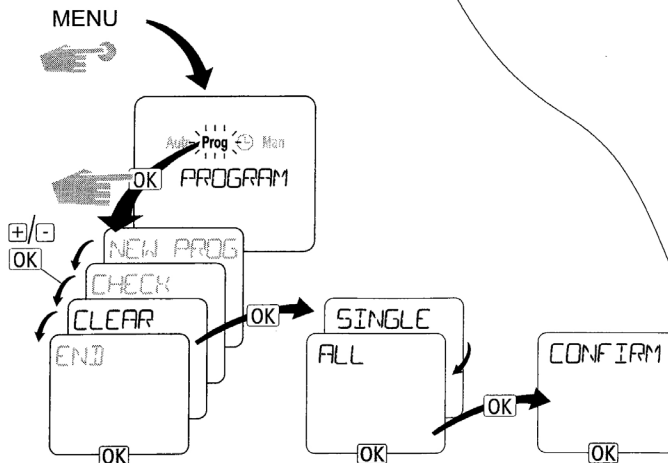

Via the automatic menu  
**Auto only**

	Channel C1 	Channel C2 
Press the two keys for <b>approx. 1 s.</b>	<b>Manual preselection:</b> Press keys simultaneously. <b>Channel C1</b> switches alternately ON or OFF. Symbol  appears. Manual preselection is corrected again by the stored program.	<b>Manual preselection:</b> Press keys simultaneously. <b>Channel C2</b> switches alternately ON or OFF. Symbol  appears. Manual preselection is corrected again by the stored program.
Press both keys for <b>approx. 2 s.</b>	<b>Permanent</b> ON OFF	<b>Permanent</b> ON OFF
<b>Cancellation of manual preselection/ permanent switching:</b> Briefly press the keys shown above.		

# PREPARATION

## Setting/ correcting the date and time summer/winter time

### Automatic summer/winter time correction

According to version the timer is pre-programmed ex-works complete with the changeover. Should you switch off the automatic facility or wish to alter it, first of all read the text display. Select by pressing ⊕ or ⊖.

Store by pressing **OK**.

### Read the text display first of all.

Select by pressing the ⊕ key or ⊖ key.  
Store by pressing the **OK** key.

### Free Prog to select sum/win changeover other than EUR-GB-USA.

Select sum/win, and after with sum/win. Store with **OK**.

Select rule FREE – with buttons ⊕ or ⊖.

Input month and weeks for sum/win. Store with **OK**.

E.g. Month = March

Week 4 = fourth week

Week 5 = last week in month

**Note:** In sum/win free Prog the time change is set automatically at sunday 2 AM.  
Time change is not available.

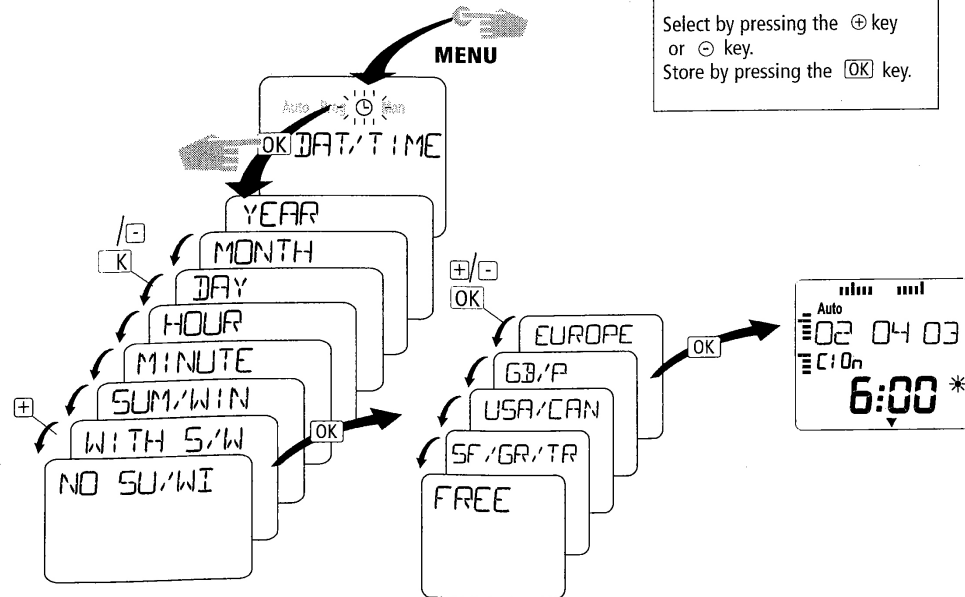

## PIN code

### PIN

The device can be locked against unauthorized use with a 4 digit code number.

Select the **Manual** menu using ⊕ oder ⊖ .  
Confirm with the **OK** button.

#### Selection **WITH PIN**

Select **WITH PIN** using ⊕ oder ⊖ .

Confirm with the **OK** button. Make note of any desired 4-digits number.

Select the first digit of your 4 digit code using ⊕ or ⊖ .

Confirm the entered digit with **OK** .

Select further digits as described using ⊕ oder ⊖ .  
Confirm each selected digit with the **OK** button.

The device is locked 90 sec. after the last keystroke and can only be operated after the correct PIN code is entered.

#### Selection **WITHOUT PIN**

Select **WITHOUT PIN** using ⊕ oder ⊖ .

Confirm with the **OK** button.

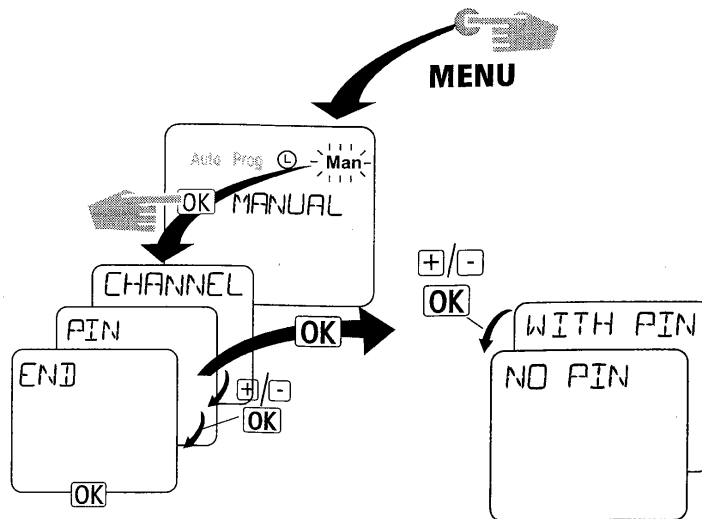

If a PIN code has been activated, the timer can no longer be activated without a valid PIN code after a RESET.

**The device must be sent in!**

## OPERATION

1. The water recycling treatment system is now ready to operate.
2. Ensure the switches on the **Control Panel** are in the following position:

*Auto-Backwash Controller*

**ON**

*Sump Pump*

**ON**

*Filter Pump*

**ON**

*Transfer Pump*

**ON**

*pH/ORP Meters*

**ON**

*pH Pump*

**ON**

*ORP Pump*

**ON**

3. With the sump pump running, use the Water Inlet Flow Control Valve to make sure the flow is at a level so it does not over flow the holding tank.
  4. Monitor the system closely the first few days to ensure smooth operation.
-

# MAINTENANCE

## WASTE OIL DECANTER

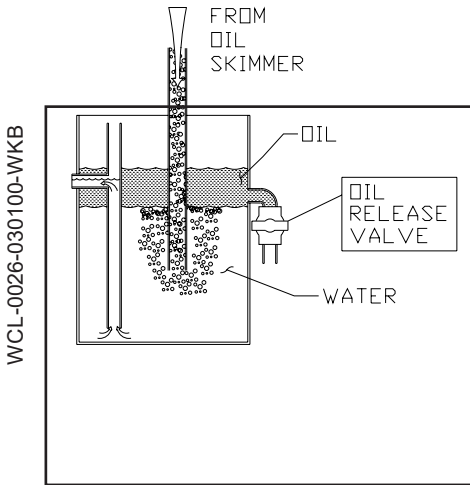

## WASTE OIL DECANTER:

1. The **Oil Skimmer** removes the top layer of oil and water from the **Oil Separation Chamber** and sends it to the **Waste Oil Decanter**.
2. As the **Waste Oil Decanter** fills with the oil/water mixture, the oil will float to the top while the water remains on the bottom.
3. The water then moves up the standpipe, through the **Oil Decanter Outlet**, and back to the **Wash Water Catch Pit** to be recycled again.
4. As oil accumulates, it will have to periodically be removed from the **Waste Oil Decanter**.
  - a. Place a 5 gallon bucket below the hose on the Waste Oil Release Valve
  - b. Open the Waste Oil Release Valve and allow oil to flow into the 5 gallon bucket. Turn off valve when water begins flowing into the bucket.
  - c. Dispose of oil according to EPA Standard

## BACKWASHING OF FILTERS:

The unit will automatically backwash at the time programmed on timer. If an additional backwash is desired, follow the manual procedures below. If more daily backwashes are desired, please follow Timer Programming Instructions.

## AUTOMATIC BACKWASH SEQUENCE:

1. **Auto-Backwash Controller Switch** must be in the "ON" position and **Automatic Backwash Timer** must be programmed to turn on.
2. **Automatic Backwash Timer** turns on at specified time.
3. **Backwashing When Lit** light turns on.
4. **Multimedia Filter Valve** moves to backwash position.
5. **Filter Pump** turns on and runs for 10 minutes.
6. **Filter Pump** turns off.
7. **Multimedia Filter Valve** moves to filter position.
8. **Polishing Filter Valve** moves to backwash position.
9. **Filter Pump** turns on and runs for 5 minutes.
10. **Filter Pump** turns off.
11. **Polishing Filter Valve** moves to filter position.

**NOTE:** If filter pump is running, backwash sequence will not start until the filter pump turns off.

# MAINTENANCE

## MANUAL START OF BACKWASH SEQUENCE:

**NOTE:** This must be done at time when pressure washers will not be in use for 15 minutes.

1. Auto-Backwash Controller Switch MUST be in the "ON" position.
2. Press Start Backwash button.
3. Backwash will continue from #3 of the "Automatic Backwash Sequence".

### Filter Mode:

In normal operation the slide valve is in filter mode and in the up position. Compressed air is forced through the air solenoid and into the bottom of the slide valve air cylinder. The air pushes the air cylinder plunger up pulling up the slide valve shaft. Discs on the slide valve shaft direct the water flow from the filter inlet to the top of the filter pod. Water travels through the media to the bottom and out the filter outlet line.

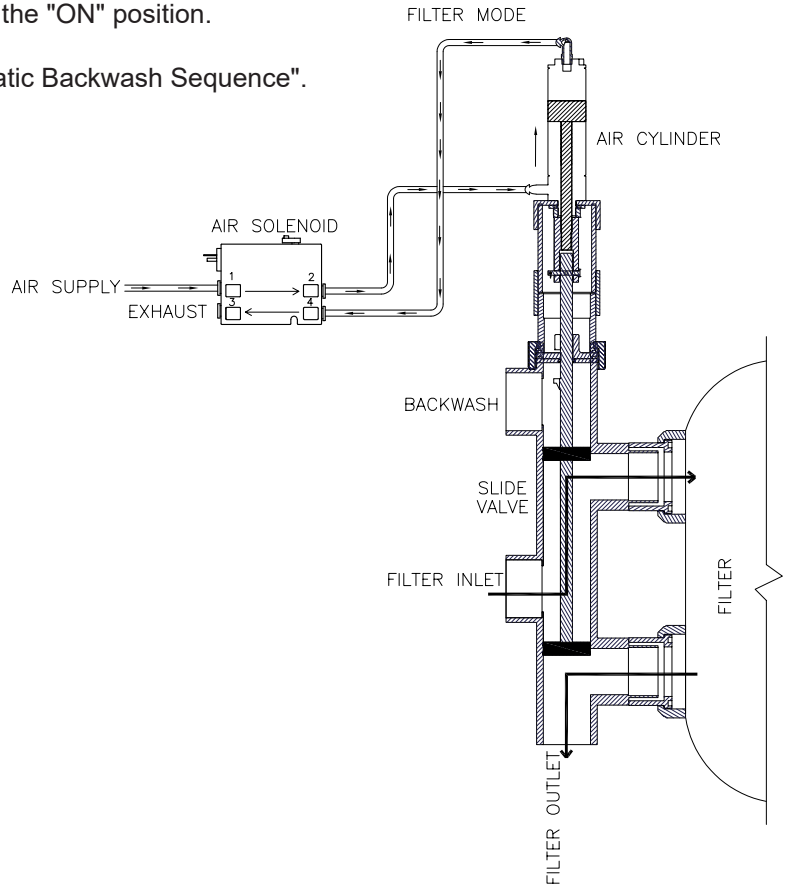

### Backwash Mode:

In backwash mode the slide valve is in the down position. The air solenoid actuates forcing compressed air to the top of the slide valve air cylinder. The air pushes the air cylinder plunger down, pushing down the slide valve shaft. Discs on the slide valve direct water flow from the filter inlet to the bottom of the filter pod. Water travels upwards through the media to the top and out the backwash line.

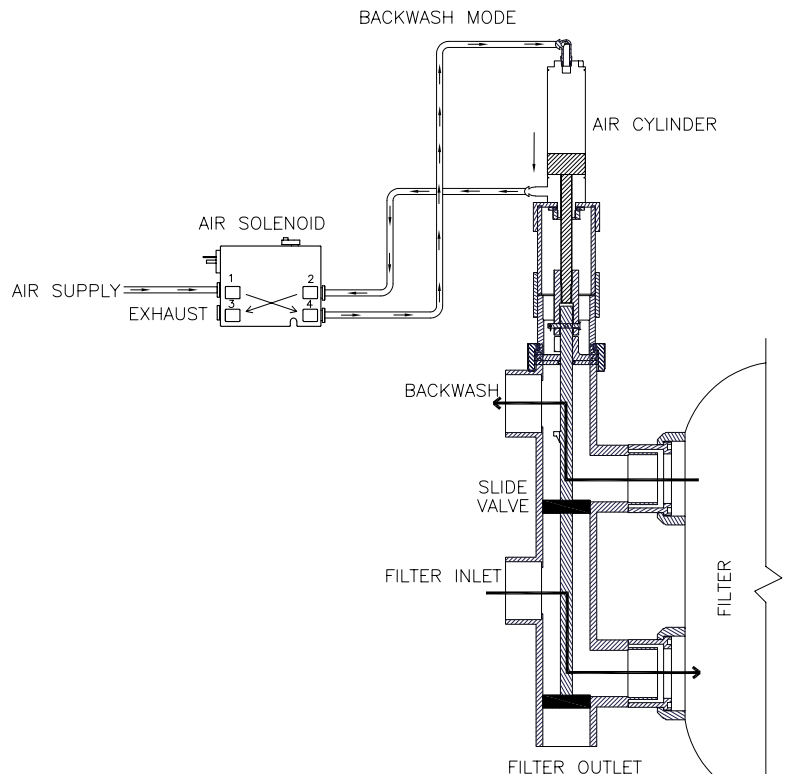

# MAINTENANCE

## ACTIVE CARBON TEST:

To ensure the **Polishing Filter** is working effectively, you should perform an active carbon test.

- I. **TEST PROCEDURE A:** For systems with pH & ORP Control, your test kit will include test strips.
  - A. Following the directions included with the test strip kit, test the water in the **Holding Tank**.
    1. The test strip should show chlorine present in the system.
    2. If no chlorine is present, check the following:
      - a. The **ORP Adjustment Chemical** is empty. Replace.
      - b. The **ORP Pump** is turned off or malfunctioning. Ensure the **ORP Pump Switch** is in the ON position. Contact your local distributor if additional maintenance is needed.
      - c. If you are not using chlorine as an ORP control, you must refer to TEST PROCEDURE B to ensure the carbon is still active.
  - B. With the **Filter Pump** operating, use a test strip to test the incoming water to the **Product Tank**.
    1. The test should not show chlorine present in the system.
    2. If chlorine is present, the carbon must be replaced. See REMOVING AND REFILLING MEDIA section.
- II. **TEST PROCEDURE B:** For systems without pH & ORP Control a test kit is available (RC-1001-0001). The test kit will include a Carbon removal scoop, 4 oz. empty container, 2 oz. empty container, 2 oz. bottle of chlorine, Chlorine test paper with color chart. Contact your local distributor if any parts are missing.
  - A. Turn off the **Filter Pump Switch**.
  - B. Unscrew the cap and remove the Polishing Filter Lid.
  - C. Fill the Carbon Removal Scoop with a sample of carbon from the **Polishing Filter** tank.
  - D. Add 2 oz. of the carbon sample into the 4 oz. empty container.
  - E. Fill the 2 oz. empty container with water.
  - F. To the water, add one drop of chlorine or five drops of chlorine bleach.
  - G. Follow the directions on the bottle of test strips. Dip a chlorine test paper into the 2 oz. container. The chlorine reading should be at least 10 parts per million. If not, add another drop of chlorine.
  - H. Add the 2 oz. of chlorine/water solution to the carbon sample in the 4 oz. container.
  - I. Tightly cap the chlorine/carbon mixture and shake occasionally for 3 minutes.
  - J. Dip a new strip of chlorine test paper into the liquid part of the 4 oz. container. Do not dip the test paper into the solid carbon as this will produce incorrect results. Read the directions on the bottle of test strips.
  - K. Check the reading against the color chart.
    1. A reading of zero means the carbon is still active.
      - a. Reassemble the **Polishing Filter** by replacing the Polishing Filter Lid.
      - b. Turn the **Filter Pump Switch** on.
    2. A positive reading means the carbon is inactive and must be replaced.



## MAINTENANCE

### REMOVING & REFILLING MEDIA FROM THE MULTIMEDIA & POLISHING FILTER:

1. New media can be ordered from your local distributor using the part numbers listed below.

Model	Part number	Description	Quantity	Weight (lbs.)
<b>WLP-20AB-0M11/</b>				
<b>WLP-20AB-0M31</b>	<b>19-0561</b>	<b>30" MEDIA FILTER</b>	<b>1</b>	
	33-0303	GRAVEL #3		200
	33-0304	GARNET #12		100
	33-0403	GARNET #80		200
	33-0306	FILTER AG		50
	<b>19-0560</b>	<b>24" POLISHING FILTER</b>	<b>1</b>	
	33-0302	ACTIVATED CARBON		110
<b>WLP-40AB-0M11/</b>				
<b>WLP-40AB-0M31</b>	<b>19-0562</b>	<b>36" MEDIA FILTER</b>	<b>1</b>	
	33-0303	GRAVEL #3		300
	33-0304	GARNET #12		200
	33-0403	GARNET #80		300
	33-0306	FILTER AG		100
	19-0561	<b>30" POLISHING FILTER</b>	<b>1</b>	
	33-0302	ACTIVATED CARBON		165

2. Be certain to wear proper attire such as goggles, gloves, coveralls, dust mask, etc. to protect eyes and skin.
3. Turn off the **Filter Pump Switch**.
4. Remove the top from the desired filter tank and drain water.
5. Use a vacuum to remove the media from the filter.
6. Ensure the lateral assembly remains centered and flush on the bottom of the tank and the layers are level when pouring media into the filter tank.
7. Reassemble the dispersing section of the filter tank and replace its lid.
8. Turn on the **Filter Pump Switch**. DO NOT backwash **Multi-Media Filter** until unit has been in operation for 24 hours.
9. Dispose of used media according to EPA standards.

### SLIDE VALVE:

The **Slide Valve** needs to be disassembled so the o-rings can be greased on a monthly basis. The manufacturer recommends using a water proof grease and apply the grease liberally.

# MAINTENANCE

## WATER TESTING:

Water chemical makeup should be tested on a weekly basis. With the **Sump Pump** operating, use a test strip, test the incoming water to the **Holding Tank**. (Follow the directions given with your test strips.) Use the flow chart below to check and correct the following:

1. pH: Acidity and alkalinity in the water. Low pH (acidic) will cause rusty looking water.
2. Alkalinity: Dissolvable salts in the water. Too much alkaline causes cloudiness and reduces filter life.
3. Calcium Hardness: Calcium in the water. Too much calcium creates scale buildup in coils of hot water pressure washers.
4. \*Free Chlorine: Chlorine which is not combined with dirt, oils, etc. Controls odor, bacteria and algae formation.  
\*If using chlorine as a water purifying agent.

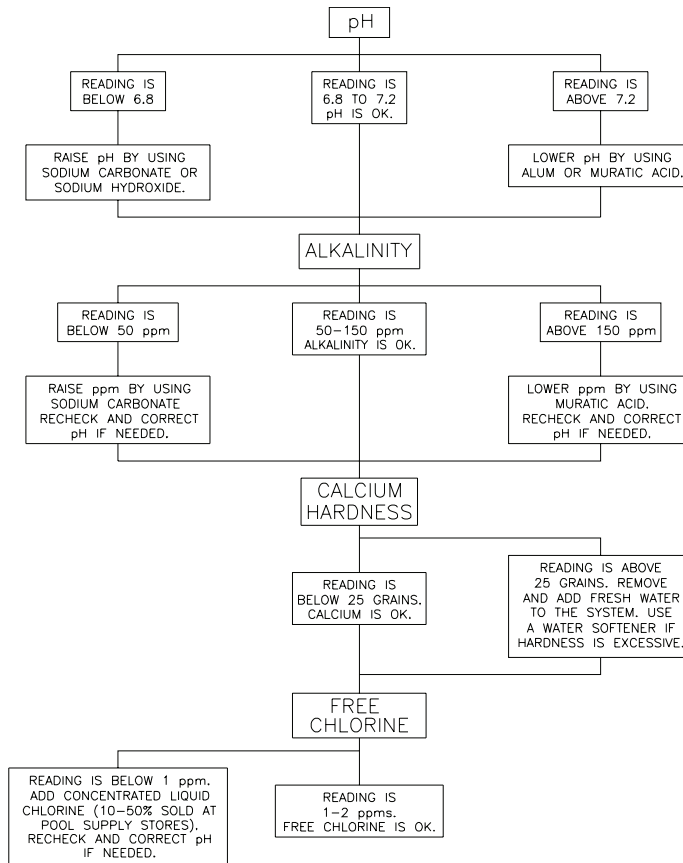

WLP-0015-112398-JJ

## MAINTENANCE:

1. Clean pH AND ORP probes every 1-2 months.
  - a. Shut off sump pump, wait for drain line to drain and loosen aluminum strain relief around probe to remove.
  - b. Use water or vinegar and a soft cloth or Q-tip to wipe away build up on the probe.
  - c. Place probe back in line, with tip at center of piping. Tighten strain relief around probe. **DO NOT OVERTIGHTEN.**

*Note: probes will be damaged if they are allowed to dry out. If they will be exposed to air for more than a few hours keep tip submerged in water or the storage solution that comes with the probe.*

*Note: probes have a shelf life of about 1 year so it's recommended to replace the probes yearly.*
2. Calibration of pH meter. You should recalibrate the external meter 1 or 2 times a year. You should also always recalibrate the meter when a pH probe has been replaced. Follow the calibration instructions below for the pH meter. An electronic calibrator can be used in place of the buffer solutions.

## MAINTENANCE

### BUFFER 1 (STAND) CALIBRATION:

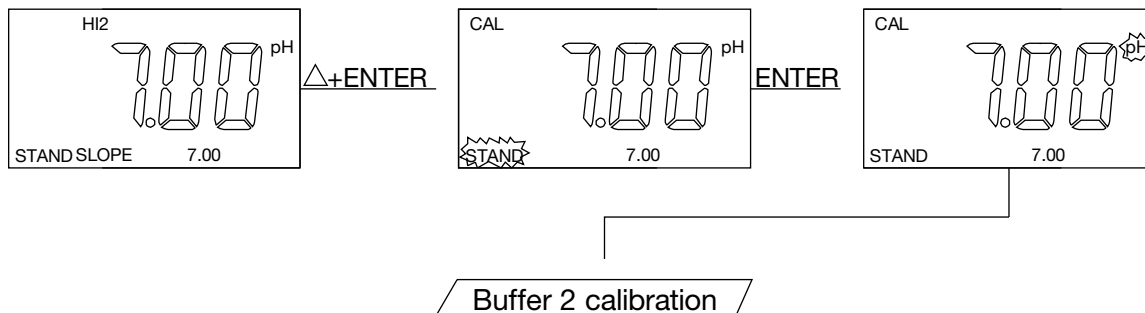

Enter into the pH calibration mode, the “STAND” icon will flash, the unit is ready to be standardized at the first buffer. Rinse the pH and ATC/Temp probes in distilled water and immerse them in the first buffer solution (either 7.00 or 6.86). Allow temperature reading to stabilize, then press “ENTER” key to calibrate. The “pH” icon will flash until the unit detects a stable reading. Once the unit calibrates the first point, the “SLOPE” icon will flash. The unit is ready to be sloped at the second buffer.

### BUFFER 2 (SLOPE) CALIBRATION:

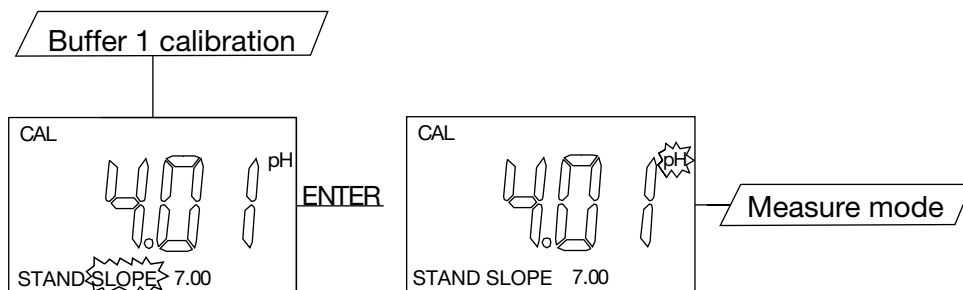

Rinse the pH and ATC/Temp probe in distilled water and immerse them in the second buffer solution (either 4.00/4.01 or 9.18/10.01). Allow temperature reading to stabilize, then press “ENTER” key to calibrate. The “pH” icon will flash until the unit detects a stable reading. Once the unit calibrates the second point and the unit will automatically exit the calibration mode and goes to the pH Measure mode. Dual point calibration is complete.

*Note: In the Setting mode (1. Temperature compensation select), select 03 (Manual temperature compensation mode) if no temperature probe is being used. Press the [UP] key or [DOWN] key in the Manual temperature compensation mode to adjust the value to that of the test solution temperature. Then calibrate buffer 1 and buffer 2.*

### ORP CALIBRATION:

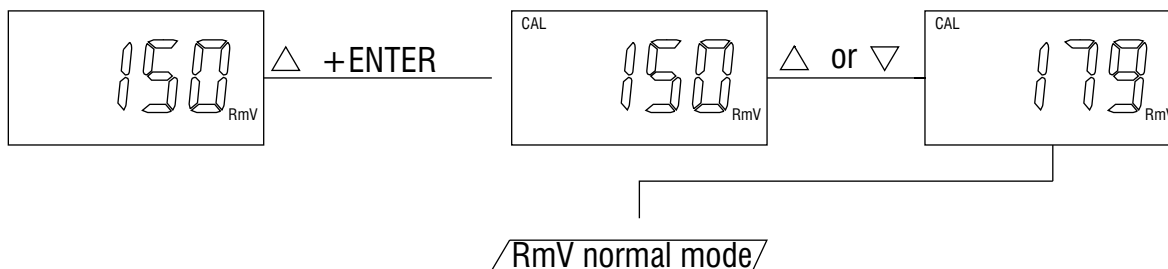

The model TX20 uses 1-point calibration for RmV. In the **RmV Measure mode**, pressing [UP] key and [ENTER] key at the same time, the meter will enter into **RmV calibration mode**. Rinse the ORP probe in distilled water and immerse it in the ORP standard solution, then press [UP] or [DOWN] key to adjust the ORP value to that the ORP standard. Press [ENTER] key to save. The unit beeps to indicate a successful calibration. Calibration is now complete and the unit will automatically switch to the ORP relative mV **Measure mode**.

## MAINTENANCE

### WINTERIZING:

If you must store your unit in an area where the temperature may fall below 32°F/0°C, you can protect your water recycling treatment system by draining all water from the system.

1. Follow the backwashing/cleaning procedures for the **Multi-Media Filter** and **Polishing Filter**
2. Turn all switches on the **Control Panel** to the OFF position and disconnect power to the **Control Panel**.
3. Open the check valve near the **Sump Pit** and drain the water transport line. Drain **Sump Pump**.
4. Open check valve at the inlet and drain the inlet line.
5. Remove drain plug from **Multi-Media Filter** and **Polishing Filter** and loosen the lid on each filter. Break the unions on each side.
6. Remove the drain plug from the **Filter Pump**.
7. Remove the drain plug from the **Transfer Pump**.
8. Remove the drain plugs from the **Sump Pump**.
9. Follow the procedures listed for the solids collection area in the maintenance section. Completely drain the **Coalescing Tank**.
10. Remove the **pH and ORP Sensor Probes** and place them in their original containers filled with deionized water. Store at room temperature.
11. Store all chemicals at room temperature.

## TROUBLESHOOTING

SYMPTOM	PROBABLE CAUSE	REMEDY
<p><b><u>SUMP PUMP</u></b>  <b>Sump Pump</b> will not run.</p>	Floats are not adjusted correctly in the <b>Sump Pit</b> .	Readjust.
	Not enough water in the <b>Sump Pit</b> .	Add water to the <b>Sump Pit</b> .
	Float 1 is defective.	Replace.
	<b>High Sump Pump Float</b> in the <b>Holding Tank</b> has flipped up.	Wait for water to drain from holding tank. Then push <b>High Sump Pump Float</b> down, or remove excess water in the <b>Holding Tank</b> .
	Circuit overload/breaker has tripped.	Reset breaker or replace fuse at power source.
	Motor overload.	Allow motor to cool. Motor will automatically restart when cool.
<p>-----</p> <p><b>Sump Pump</b> motor starts and stops frequently.</p>	Motor is defective.	Replace pump.
	This is a common occurrence on initial start-up while pits are filling.	Allow pits to fill.
	Excessive water flow to reclaim unit.	Turn valve clockwise to reduce flow.
	<b>Sump Pump</b> impeller is clogged.	Disconnect power and unclog impeller.
	Motor overload.	Allow motor to cool. Motor will automatically restart when cool.
	<b>Sump Pit</b> is not large enough.	Expand size of pit.
<p>-----</p> <p><b>Sump Pump</b> runs, but there is little or no water discharge.</p>	Strainer basket in <b>Sump Pump</b> is clogged.	Clean, repair or replace
	Water level is below pump inlet.	Ensure Float 1 is not caught in plumbing.
	There is an air lock in the <b>Sump Pump</b> .	Manually fill the inlet pipe with water.
	Low voltage.	Ensure wire size is capable of handling the rated amperage of the unit. If wire size is correct, contact your distributor.
<p>-----</p> <p><b>Sump Pump</b> will not turn off.</p>	Clogged impeller or worn pump parts.	Contact your distributor.
	Defective switch inside Float 1.	Replace.
	Pump is air locked.	Cycle pump in one minute, increments several times to clear air from pump.

## TROUBLESHOOTING

SYMPTOM	PROBABLE CAUSE	REMEDY
<b><u>ELECTRICAL</u></b>		
No power at <b>Control Panel</b> .	Power failure to <b>Control Panel</b> .	Check circuit breaker at power source or contact your local distributor.
<b>Power Indicator Light</b> is OFF.	Blown fuses inside <b>Control Panel</b> .	Check fuses, replace if necessary. If fuses are OK, contact your distributor.
<b><u>COALESCING TANK</u></b>		
Water will not flow into the <b>Oil/Water/Solids Separator</b> .	<p><b>Sump Pump</b> is not turned on.</p> <p>Circuit breaker has tripped or is "OFF".</p> <p><b>High Sump Pump Float</b> in Holding Tank is malfunctioning.</p> <p>Strainer basket in <b>Sump Pump</b> is clogged.</p> <p>Dirt is lodged in the check valve.</p> <p><b>Sump Pump</b> impeller is clogged.</p> <p>Lines or valves contain frozen water.</p>	<p>Move <b>Sump Pump Switch</b> to "ON".</p> <p>Reset or turn breaker "ON".</p> <p>Check On/Off with voltmeter, repair or replace.</p> <p>Clean, repair, or replace.</p> <p>Clean.</p> <p>Disconnect power and clean.</p> <p>Allow to thaw. Inject with warm water. water if necessary.</p>
<b><u>SHAFT SEALS</u></b>		
Water is leaking at pumps.	Damaged stationary shaft seal.	Seal ran dry. Ensure seal chamber is filled with liquid.
Short seal life.	Unexpected temperature and chemical usage.	Replace.

## TROUBLESHOOTING

SYMPTOM	PROBABLE CAUSE	REMEDY	
<b><u>FILTER PUMP</u></b>			
<b>Filter Pump</b> will not run.	<b>Filter Pump Switch</b> is off.	Turn switch on.	
	Circuit overload/breaker has tripped.	Reset breaker or replace fuse.	
	Motor overload.	Allow motor to cool. Motor will automatically restart when cool.	
	<b>Filter Pump Switch</b> is malfunctioning.	Replace switch.	
	<b>Low Filter Pump Float</b> or <b>High Filter Pump Float</b> is malfunctioning.	Check On/Off with voltmeter, repair or replace.	
<b>Filter Pump</b> runs but there is no water discharge OR <b>Filter Pump</b> cycles excessively.	Plumbing is obstructed.	Remove obstruction.	
	Pump sucking air.	Eliminate leaks and tighten all connections on intake line.	
	Low water in <b>Holding Tank</b> .	Increase flow by opening <u>Water Inlet Flow Control Valve</u> .	
	Check valve is leaking or stuck in closed position.	Clean or replace as necessary.	
	Filters are dirty.	Backwash filters.	
	Lines or valves contain frozen water.	Allow to thaw. Inject with warm water if necessary. Ensure the <b>Sump Pit</b> remains above freezing.	
	Pump impeller is obstructed.	Disconnect power and clean.	
	Pump motor is operating below maximum RPM.	Contact your local distributor.	
	<b>Filter Pump</b> is hot or turns off.	<b>Multi-Media Filter</b> is dirty.	Backwash.
		Low voltage.	Ensure wire size is capable of handling the rated amperage of the unit. If wire size is correct, contact your local distributor.
Motor overload.		Allow motor to cool. Motor will automatically restart when cool.	

## TROUBLESHOOTING

SYMPTOM	PROBABLE CAUSE	REMEDY
<b><u>TRANSFER PUMP</u></b>		
<p><b>Transfer Pump</b> runs but there is low water discharge.</p>	Water is being used elsewhere.	Reduce flow to other source or contact your local distributor.
	<b>Low Transfer Pump Float</b> is not functioning.	Check On/Off with voltmeter. Repair or replace.
	Timer kicked in. Water is recycling	Do not run pressure washers while water is in timed recycle mode.
	<b>Rain Water Overflow</b> is discharging too much water.	Reduce flow by adjusting solenoid on the <b>Rain Water Overflow</b> .
	Plumbing is obstructed or too small.	Remove obstruction or use larger plumbing.
	Scale buildup in metal piping.	Replace with plastic plumbing.
<p><b>Transfer Pump</b> cycles excessively.</p>	Solenoid valve(s) is open or stuck open.	Fix Solenoid valve(s) or reduce flow.
	Pump sucking air.	Eliminate leaks and tighten all connections on intake line.
	Bladder failure in <b>Pressure Tank</b> .	Replace <b>Pressure Tank</b> .
	Pressure switch malfunction.	Adjust pressure settings.
	Too low of pressure in the <b>Pressure Tank</b> .	Increase pressure.
<p><b>Transfer Pump</b> does not turn off.</p>	Wait 10 minutes when no water is being discharged.	Normal Operation.
	Pressure switch line is obstructed.	Disconnect line and remove obstruction. Replace.
	Pressure switch is out of alignment.	Realign or replace.
	Pressure switch contacts are frozen.	Replace if necessary.
	Impeller is obstructed.	Contact your local distributor.



## TROUBLESHOOTING

SYMPTOM	PROBABLE CAUSE	REMEDY
<b><u>SOLENOIDS</u></b>		
Solenoid valve won't turn on.	Low or no water pressure.	Turn off water, switch solenoids between valves. Turn on water. If problem is corrected, replace faulty solenoid.
	No electrical contact to solenoid.	Contact your local distributor.
Solenoid valve leaks when turned off.	Solenoid is obstructed.	Turn off water, remove and clean solenoid.
	Damaged solenoid.	Replace.
	Solenoid o-ring is misaligned or damaged.	Realign or replace.
	Diaphragm seat is dirty.	Clean or replace.
	Diaphragm is damaged.	Replace.
<b><u>ODOR</u></b>		
Excessive odor in water system.	Not enough chemicals in the system to maintain water balance.	Increase the pH and ORP set points.
	Water remains dormant in the system too long causing bacteria buildup.	Increase timer settings to recycle water.
<b><u>CHEMICALS</u></b>		
Excessive chemical usage.	<b>pH and ORP Meters</b> are calibrated incorrectly or faulty probes.	Recalibrate meters or change probes.
Low chemical usage (with possible odor.)	Chemical pumps are not working.	Replace chemical hose inside pump. Recalibrate <b>pH and ORP Meters</b> .
<b><u>WATER FLOW</u></b>		
Air shoots from Water Outlet.	This is a common occurrence while pump is priming.	Air will stop shooting from the water outlet when pump is primed.
	<b>Transfer Pump</b> is sucking air at suction inlet.	Eliminate leaks or tighten connection.
Water will not turn off.	Solenoid failure.	Repair or replace.

## TROUBLESHOOTING

SYMPTOM	PROBABLE CAUSE	REMEDY
<p><b><u>AUTO-BACKWASH SYSTEM</u></b>  <b>Filter Pump</b> are not fully extended or retracted. Filter valves do not extend or retract.</p>	No air pressure.	Ensure Air System Inlet pressure is at or above 60PSI.
	Debris in Filter Valve.	Call dealer to repair.
	Lack of lubrication in Filter Valve.	Increase air pressure at <b>Air System Inlet</b> until valve extends. <b>Do not exceed 100PSI.</b> Call dealer to repair.
	Pinched air line.	Check all air lines.
	Ruptured air line.	Replace.
	Faulty air valve.	Call dealer to repair.
<p>-----</p> <p><b>Filter Pump</b> cycles continuously during backwash sequence.</p>	Backwash flow rate is higher than inlet flow rate.	<p><b>Sump Pump</b> malfunctioning. See <b>Sump Pump</b> section of troubleshooting.</p> <p>Increase inlet flow by opening <u>Water Inlet Flow Control Valve</u>.                      (See PREPARATION, START-UP)</p> <p>Decrease backwash flow by closing <u>Filter Control Valve</u>.                      (See PREPARATION, START-UP)</p>
<p><b><u>pH / ORP Meters</u></b>  <b>pH Pump</b> is not running when HIGH light on <b>pH Meter</b> is lit.  <b>ORP Pump</b> is not running when LOW light on <b>ORP Meter</b> is lit.</p>	<p><b>pH</b> or <b>ORP Pump Switch</b> is in the "OFF" position.</p> <p>pH or ORP Meter reading is not numeric</p> <p>Pump Shaft is stuck</p>	<p>Turn to "ON" position.</p> <p>Turn <b>pH / ORP Meters Switch</b> to "OFF" position for 5 seconds then turn "ON" again.</p> <p>Turn shaft of pump with fingers to loosen shaft</p>

## TROUBLESHOOTING

pH/OPR DISPLAY	TEMPERATURE DISPLAY	DISPLAY MODE	POSSIBLE CAUSE(S) [ACTION(S)]
<b><u>OvEr</u></b>	-10.0~120.0 °C	pH measure mode	pH > 16.00pH [Recalibrate], replace probe
<b><u>Undr</u></b>	-10.0~120.0 °C	pH measure mode	pH > -2.00pH [Recalibrate], replace probe
<b><u>OvEr</u></b>	OvEr	pH measure mode	a. Temperature > 120.0 °C [Bring buffer solution to lower temperature.] [Replace temperature probe.] b. No temperature sensor. [Adjust the manual temperature to -10~120 °C.]
<b><u>OvEr</u></b>	Undr	pH measure mode	a. Temperature > -10.0 °C [Bring buffer solution to higher temperature.] [Replace temperature probe.] b. No temperature sensor. [Adjust the manual temperature to -10~120 °C.]
<b><u>OvEr</u></b>	Temperature reading	Absolute ORP mV or relative ORP	Absolute ORP mV > +1999 mV a. Bring solution down to lower ORP b. Recalibrate c. Replace probe
<b><u>Undr</u></b>	Temperature reading	Absolute ORP mV or relative ORP	Absolute ORP mV > -1999 mV a. Bring solution up to higher ORP b. Recalibrate c. Replace probe



## STATEMENT OF WARRANTY

The manufacturer warrants all parts (except those referred to below) of your new WLP Water recycling Treatment system to be free from defects in materials and workmanship during the following periods:

For One (1) Year from the date of original purchase:

Defective parts not subject to normal wear and tear will be repaired or replaced at the manufacturer's option during the warranty period. In any event, reimbursement is limited to the purchase price paid.

### EXCLUSIONS

1. The motor is covered under separate warranty by its respective manufacturer and is subject to the terms set forth therein.
2. Normal wear parts:

Seals	Filters	Gaskets
O-rings	Packings	Pistons
Valve Assembly	Brushes	Filtering Media
Sensors		
3. Parts damaged due to:
  - normal wear, misapplication, modifications/alterations, abuse,
  - operation at other than recommended speeds, pressures or temperature,
  - the use of caustic liquids,
  - chloride corrosion or chemical deterioration,
  - fluctuations in electrical or water supply,
  - operating unit in an abrasive, corrosive or freezing environment.
4. Parts damaged by failure to follow recommended:
  - installation, operating and maintenance procedures.
5. This warranty does not cover the cost of:
  - normal maintenance or adjustments,
  - labor charges,
  - transportation charges to Service Center,
  - freight damage.
6. The use of other than genuine manufacturer parts will void warranty. Parts returned, prepaid to the manufacturer's factory or to an Authorized Service Center will be inspected and replaced free of charge if found to be defective and subject to warranty. There are no warranties which extend beyond the description of the face hereof. Under no circumstances shall the manufacturer bear any responsibility for loss of use of the unit, loss of time or rental, inconvenience, commercial loss or consequential damages.



Manufactured by Mi-T-M  
50 Mi-T-M Drive, Peosta IA 52068  
563-556-7484/ Fax 563-556-1235