

*Making a positive impact on
our environment for today
and future generations.*

WLP & WCP Series



WLP Series

Advanced Wash Water Recycle Systems



WLP-20-OM10

THESE RECYCLE SYSTEMS ARE DESIGNED TO REMOVE FREE HYDROCARBONS AND FILTER WATER TO BE SENT BACK THROUGH A PRESSURE WASHER. THEY FEATURE pH AND ORP INJECTION AND ARE DESIGNED WITH CORROSION-RESISTANT TANKS.

FEATURES

- Poly skid is non-corrosive
- Easily accessible pumps
- Corona discharge ozone system
- Advanced oil/water/solids separator
- ORP/pH controller
- Customized multi-media filter
- Activated carbon filter
- 1.0 HP surface-mount sump pump



Hose connectors are designed for easy accessibility and quick installation

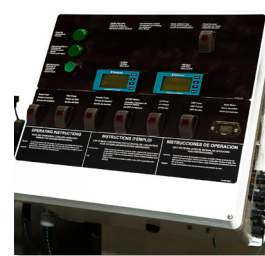

ETL listed NEMA-4 rated corrosion-proof control panel for safe and reliable operation



Recommended Air Compressor, AM1-HE02-05M, for use with auto-backwash models

AM1-HE02-05M

4.2 CFM @ 90 PSI
2.0 HP, 120V, 15.0A Electric Motor
5-Gallon Twin Tank Receivers

| MODEL NUMBER | FLOW RATE | MEDIA FILTER (CUSTOM MIX) | CARTRIDGE FILTER | CARBON FILTER (DEGASSED) | POWER REQUIREMENTS | AIR REQUIRED | DIMENSIONS (LxWxH) | SHIP WT. |
|----------------|-----------|---------------------------|------------------|--------------------------|--------------------|---------------|--------------------|----------|
| WLP-20-OM10 | 0-20 GPM | 550 lb. | 400 sq. ft. | 110 lb. | 230V, 1Ø, 25.0A | – | 8x5x4.33ft. | 2435 lb. |
| WLP-20AB-OM11* | 0-20 GPM | 550 lb. | – | 110 lb. | 230V, 1Ø, 25.0A | 60 to 100-PSI | 8x5x4.33ft. | 2435 lb. |
| WLP-20AB-OM31* | 0-20 GPM | 550 lb. | – | 110 lb. | 230V, 3Ø, 13.0A | 60 to 100-PSI | 8x5x4.33ft. | 2435 lb. |
| WLP-40AB-OM11* | 0-40 GPM | 900 lb. | – | 165 lb. | 230V, 1Ø, 30.0A | 60 to 100-PSI | 7x9x5ft. | 3100 lb. |
| WLP-40AB-OM31* | 0-40 GPM | 900 lb. | – | 165 lb. | 230V, 3Ø, 17.0A | 60 to 100-PSI | 7x9x5ft. | 3100 lb. |

*Auto-backwash models (air required 60 to 100-PSI).
230V/208V/460V 3Ø available on all models as options.

ACCESSORIES:

| PART NUMBER | DESCRIPTION | FITS MODELS |
|-------------|--|----------------------|
| 32-0538 | pH probe – Keeps the water at an appropriate pH level so germicide is effective at killing bacteria and controlling odor | All models |
| 32-0540 | ORP probe – Measures and injects a germicide to control odor by killing odor-causing bacteria | All models |
| 55-1887 | Check valve, 2-inch – Holds prime in suction line | All models |
| AT-4007-M | Replacement air filter – Moisture trapping replacement filter | Auto-backwash models |

OPTIONS:

| PART NUMBER | DESCRIPTION | FITS MODELS |
|-------------|--|---------------|
| WX-0054 | 460V, 3Ø – Upgrades 230V models to operate at 460V | WLP-20AB-OM31 |
| WX-0055 | 460V, 3Ø – Upgrades 230V models to operate at 460V | WLP-40AB-OM31 |

WLP Series

Process & Flow Description

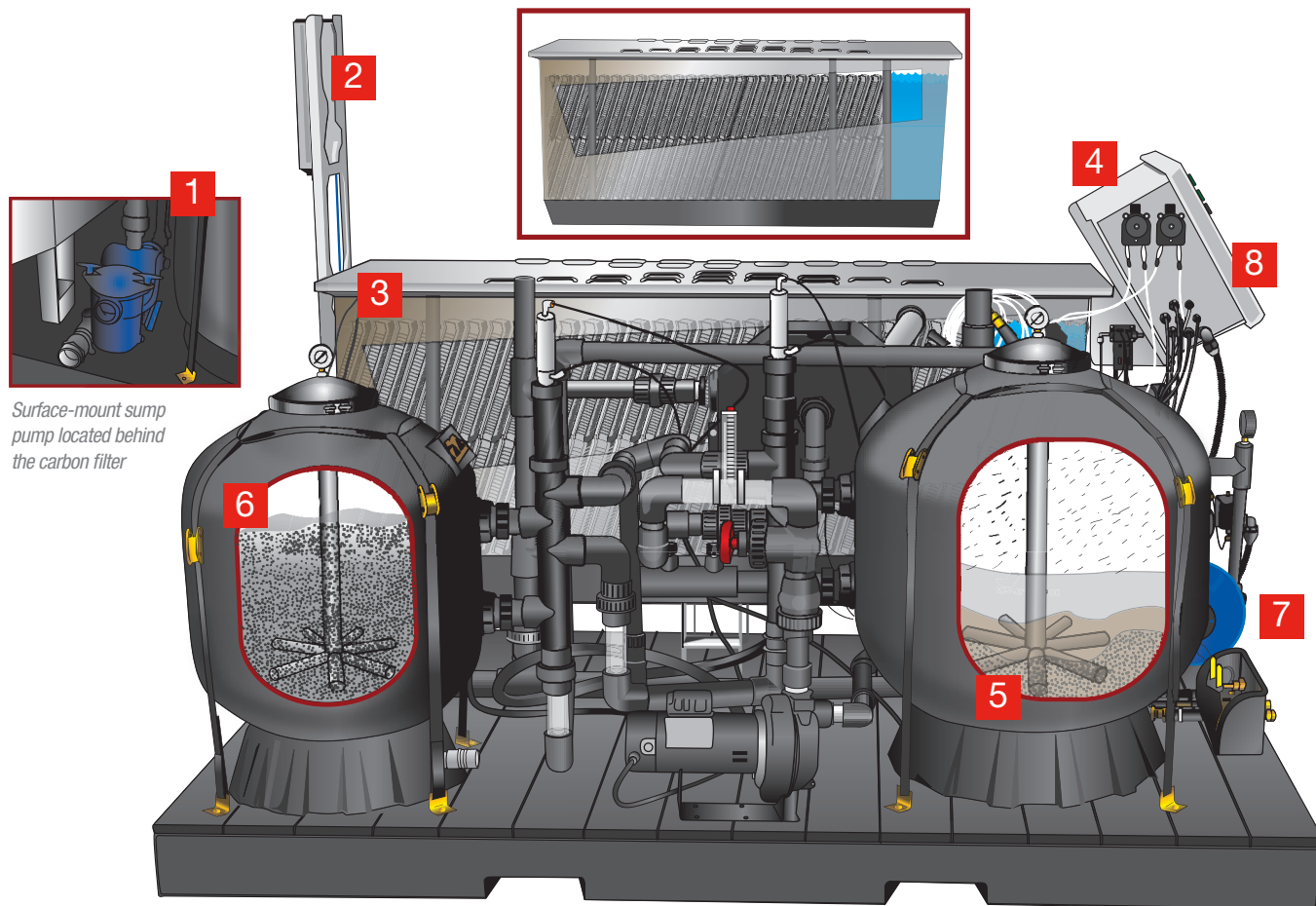

Surface-mount sump pump located behind the carbon filter

1. **SURFACE-MOUNT SUMP PUMP** – Untreated wash water is introduced into the system via a 1.0 HP surface-mount sump pump, which is included with the system, located on the unit.
2. **CORONA DISCHARGE OZONE SYSTEM** – Wash water is injected with a high concentration of ozone via a corona discharge ozone injector system for a "quick kill" of live bacteria on contact. Ozone also breaks up emulsified oils, allowing them to coalesce and float to the top of the tank for separation into the oil decanter.
3. **ADVANCED OIL/WATER/SOLIDS SEPARATOR** – As the water flows through the three-stage oil/water/solids separator, it changes directions countless times as the water is directed and redirected through four horizontal baffles and hundreds of square feet of honey-combed-shaped meshed oleophilic (oil-attracting) coalescing media. Mechanically emulsified oil particles are attracted from the water to the oleophilic media and float to the surface. Once on the surface, the oil is skimmed off into an oil decanter for easy disposal. Fine silt and particulates are dropped to the bottom of the sloped stainless-steel tank for easy flushing and disposal.
4. **ORP/pH CONTROLLER** – For longer term control of bacteria, the ORP injection system automatically measures and injects a germicide to control odor by killing odor-causing bacteria. The automated pH control system keeps the water at an appropriate pH level so germicide is effective at killing bacteria and controlling odor.
5. **CUSTOMIZED MULTI-MEDIA FILTER** – Once the water has been treated for oil and solids removal, it is then pushed through a customized multi-media filter which contains a special media blend to filter out particulates down to 25-microns.
6. **ACTIVATED CARBON FILTER** – The final treatment stage of the system occurs as the water is filtered through activated carbon which absorbs hydrocarbons, herbicides, pesticides, metals and dozens of other carbon-based constituents. Activated carbon also works as a polisher for treated water to remove chlorides.
7. **TREATED WATER IN HOLDING TANK** – Once the water is treated, it is pressurized where it will be ready for reuse at 30-PSI to 50-PSI.
8. **ELECTRICAL CONTROL PANEL** – ETL listed NEMA-4 rated corrosion-proof control panel for safe and reliable operation.

WLP Series

Sample Equipment Wash Pad Application

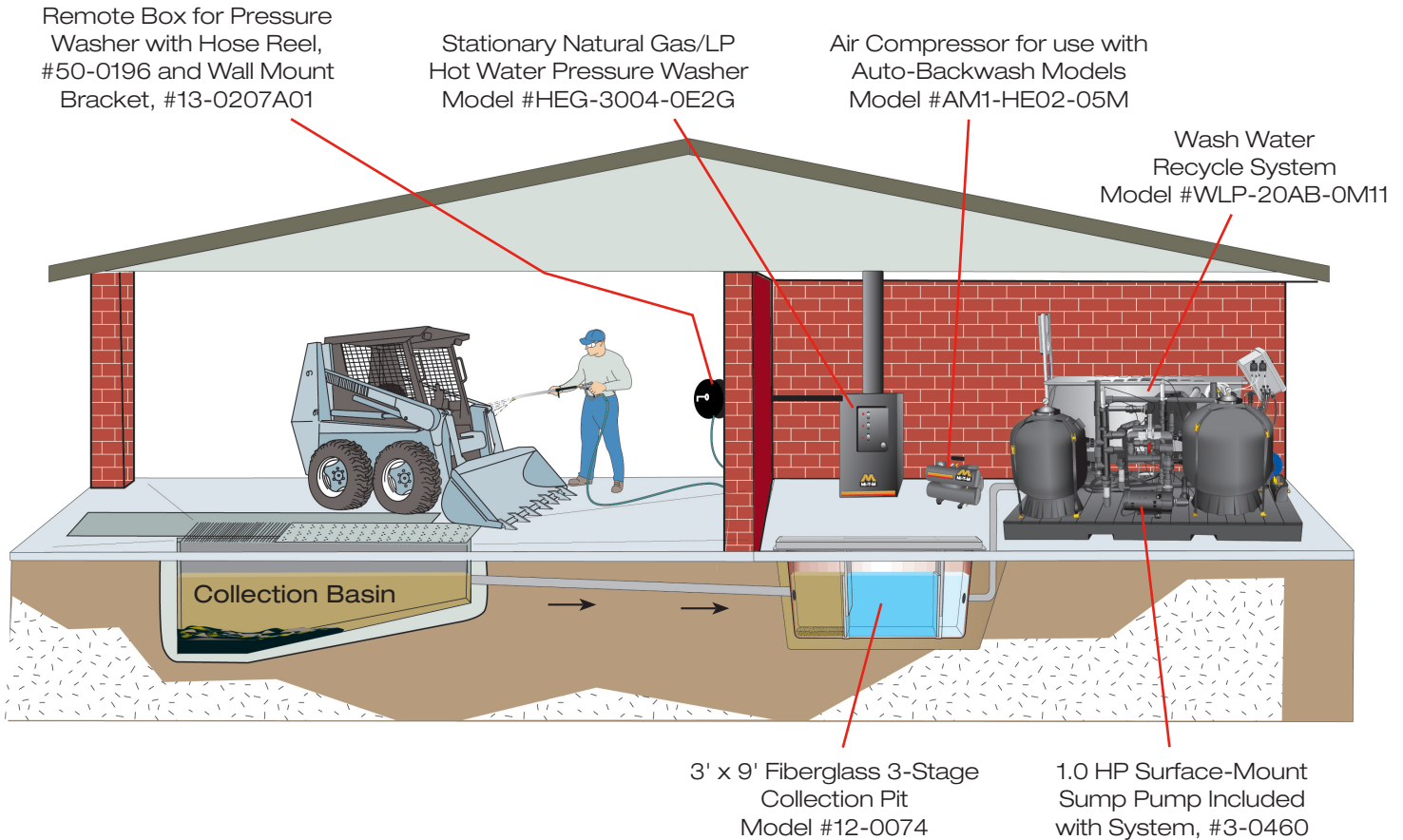

RECOMMENDED APPLICATIONS:

- Rental Yards
- Heavy Equipment Dealers
- Trucking Facilities
- Military Bases
- Truck Rental Fleets
- Diesel Repair Facilities
- Forklift Washing Operations
- Aircraft Maintenance and Restoration
- Shipyards
- Municipalities/State DOTs
- Oil Fields
- Engine Rebuilders and Manufacturers

THE IMPORTANCE OF A PROPER PIT SYSTEM:

Once equipment is washed, the untreated wash water flows into your pit system. A proper pit system for your application is the first step in proper wash water treatment and a critical element in any wash water recycle system.

Consult your dealer to determine the pit system configuration that works best for your application.

WCP Series

Clarifier Wash Water Recycle Systems

DESIGNED TO REMOVE FREE HYDROCARBONS AND FILTER WATER, THESE SYSTEMS COME STANDARD WITH pH AND ORP INJECTION AND ARE CORROSION-RESISTANT WHEN UTILIZING POLYMER TANKS AND RECYCLED PLASTIC SKIDS.



WCP-30AB-0M30

FEATURES

- Cone-shaped tank
- Heavy-duty corrosive-resistant base
- Corona discharge ozone system
- Clarifier oil/water/solids separator
- Oil decanter
- Sludge box
- Multi-media, reusable polyester and activated carbon filters
- ORP/pH controller
- 1.0 HP surface-mount sump pump



Hose connectors are designed for easy accessibility and quick installation

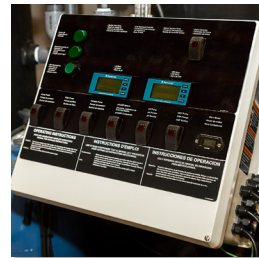

ETL listed NEMA-4 rated corrosion-proof control panel for safe and reliable operation



Recommended Air Compressor, AM1-HE02-05M, for use with auto-backwash models

AM1-HE02-05M

4.2 CFM @ 90 PSI
2.0 HP, 120V, 15.0A Electric Motor
5-Gallon Twin Tank Receivers

| MODEL NUMBER | FLOW RATE | CLARIFIER TANK | MEDIA FILTER | CARTRIDGE FILTER | CARBON FILTER | OIL COALESCING AREA | OZONE GENERATOR | POWER REQUIREMENTS | DIMENSIONS (LxWxH) | SHIP WT. |
|----------------|-----------|----------------|--------------|------------------|---------------|---------------------|-----------------|--------------------|--------------------|----------|
| WCP-20-0M10 | 0-20 GPM | 600 gallons | 350 lb. | 400 sq. ft. | 110 lb. | 425 sq. ft. | 12 grams/day | 230V, 1Ø, 30.0A | 6x8x9ft. | 2500 lb. |
| WCP-30AB-0M10* | 0-30 GPM | 600 gallons | 900 lb. | – | 165 lb. | 425 sq. ft. | 12 grams/day | 230V, 1Ø, 35.0A | 7x9x9ft. | 3470 lb. |
| WCP-30AB-0M30* | 0-30 GPM | 600 gallons | 900 lb. | – | 165 lb. | 425 sq. ft. | 12 grams/day | 230V, 3Ø, 20.0A | 7x9x9ft. | 3470 lb. |

*Auto-backwash models (air required 60 to 100-PSI).
230V/208V/460V 3Ø available on all models as options.

OPTIONS:

| PART NUMBER | DESCRIPTION | FITS MODELS |
|-------------|--|------------------------|
| WX-0039 | Pinch valve assembly – Pinch valve, bladder style (used on cone-bottom tanks), 2-inch, 120V, 1Ø | Manual backwash models |
| WX-0056 | 460V, 3Ø – Upgrades 230V models to operate at 460V | WCP-30AB-0M30 |
| WX-0133 | Coagulation system – Used in heavy solids applications to help dirt and solids settle for easy removal | All models |

WCP Series

Process & Flow Description

1. **SURFACE-MOUNT SUMP PUMP** – Untreated wash water is introduced into the system by a 1.0 HP surface-mount sump pump, which is included with the system, located on the unit.
2. **CLARIFIER OIL/WATER/SOLIDS SEPARATOR** – As the water flows through the cone-shaped oil/water/solids separator, it changes directions countless times as the water is directed and redirected through cone baffles and hundreds of square feet of oleophilic (oil-attracting) coalescing media. Mechanically emulsified oil particles are attracted from the water to the oleophilic media and float to the surface. Once on the surface, the oil is skimmed off into an oil decanter for easy disposal. Fine silt and particulates are dropped to the bottom of the sloped stainless-steel tank for easy flushing and disposal.
3. **CORONA DISCHARGE OZONE SYSTEM** – Water in the cone tank is injected with a high concentration of ozone via a corona discharge ozone injector system, tiny bubbles saturate the water in the cone tank, killing live bacteria instantly on contact. Ozone also breaks up emulsified oils, allowing them to coalesce and float to the top of the tank for separation into the oil decanter.
4. **OIL DECANTER** – Oil skimmed from the surface of the clarifier tank is captured in a conveniently located oil decanter where oil can be easily removed for disposal.
5. **SLUDGE BOX** – Solids from the wastewater stream settle at the base of the clarifier tank. With the opening of a single valve, solids are easily dropped into a bag filter in the solids separation chamber for effective capture and easy disposal. The bag filter is suspended on a dewatering tray with drainage returning to the in-ground collection pits.
6. **CUSTOMIZED MULTI-MEDIA FILTER** (Located at the back of the skid) – Once the water has been treated for oil and solids removal, it is then pushed through a customized multi-media filter which contains a special media blend to filter out particulates down to 25-microns.
7. **REUSABLE POLYESTER FILTER** – Once the larger particulates are removed, the water is then filtered through hundreds of square feet of reusable polyester 30-micron filters. (Not used on auto-backwash models)
8. **ACTIVATED CARBON FILTER** – The final treatment stage of the system occurs as the water is filtered through activated carbon which absorbs hydrocarbons, herbicides, pesticides, metals and dozens of other carbon-based constituents. Activated carbon also works as a polisher for treated water to remove chlorides.
9. **ORP/pH CONTROLLER** – For longer term control of bacteria, the ORP injection system automatically measures and injects a germicide to control odor by killing odor-causing bacteria. The automated pH control system keeps the water at an appropriate pH level so the germicide is effective at killing bacteria and controlling odor.
10. **TREATED WATER IN HOLDING TANK** – Once the water is treated, it is pressurized where it will be ready for reuse at 30-PSI to 50-PSI.
11. **ELECTRICAL CONTROL PANEL** – ETL listed NEMA-4 rated corrosion-proof control panel for safe and reliable operation.

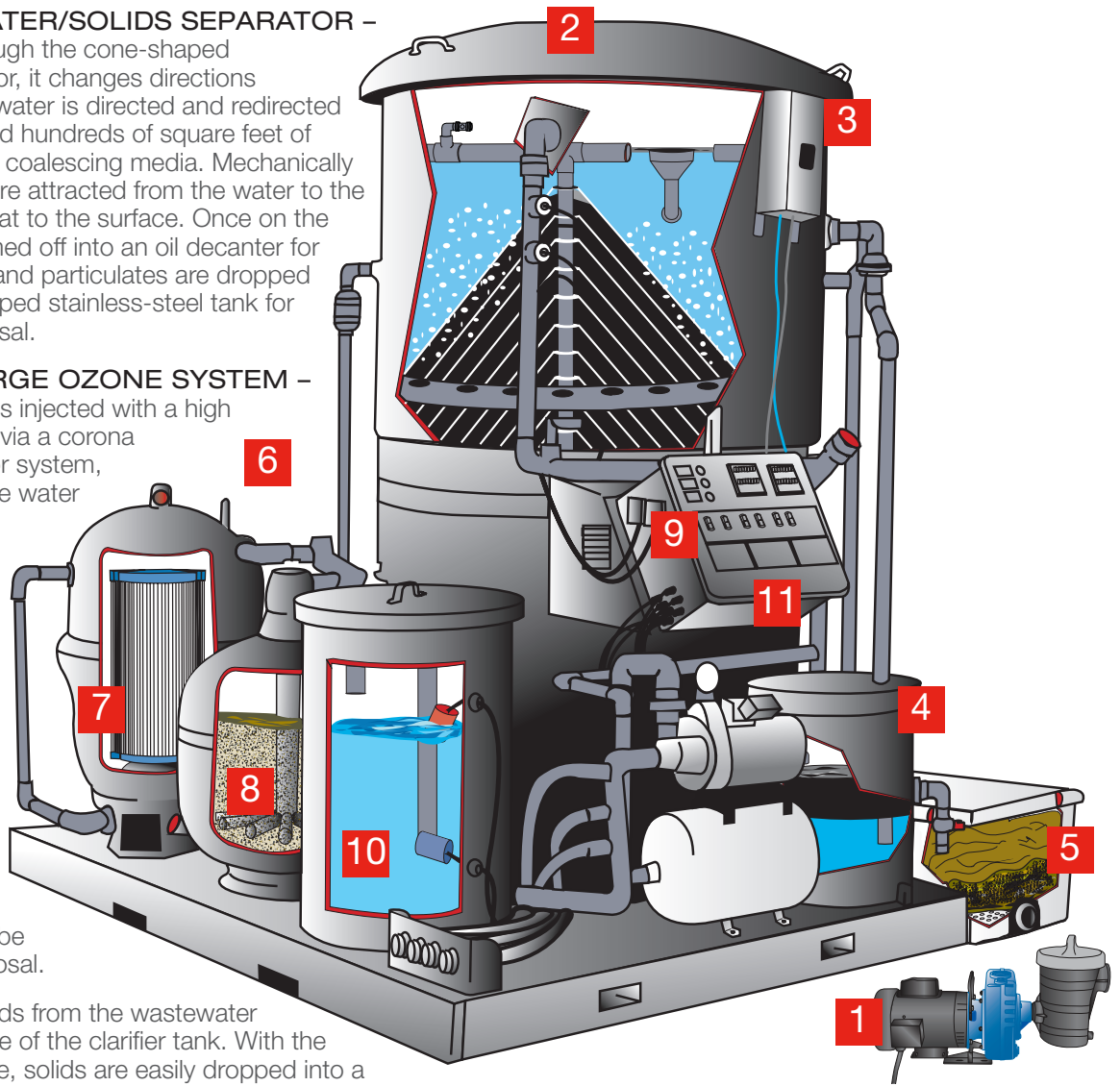

WCP Series

Sample Equipment Wash Pad Application

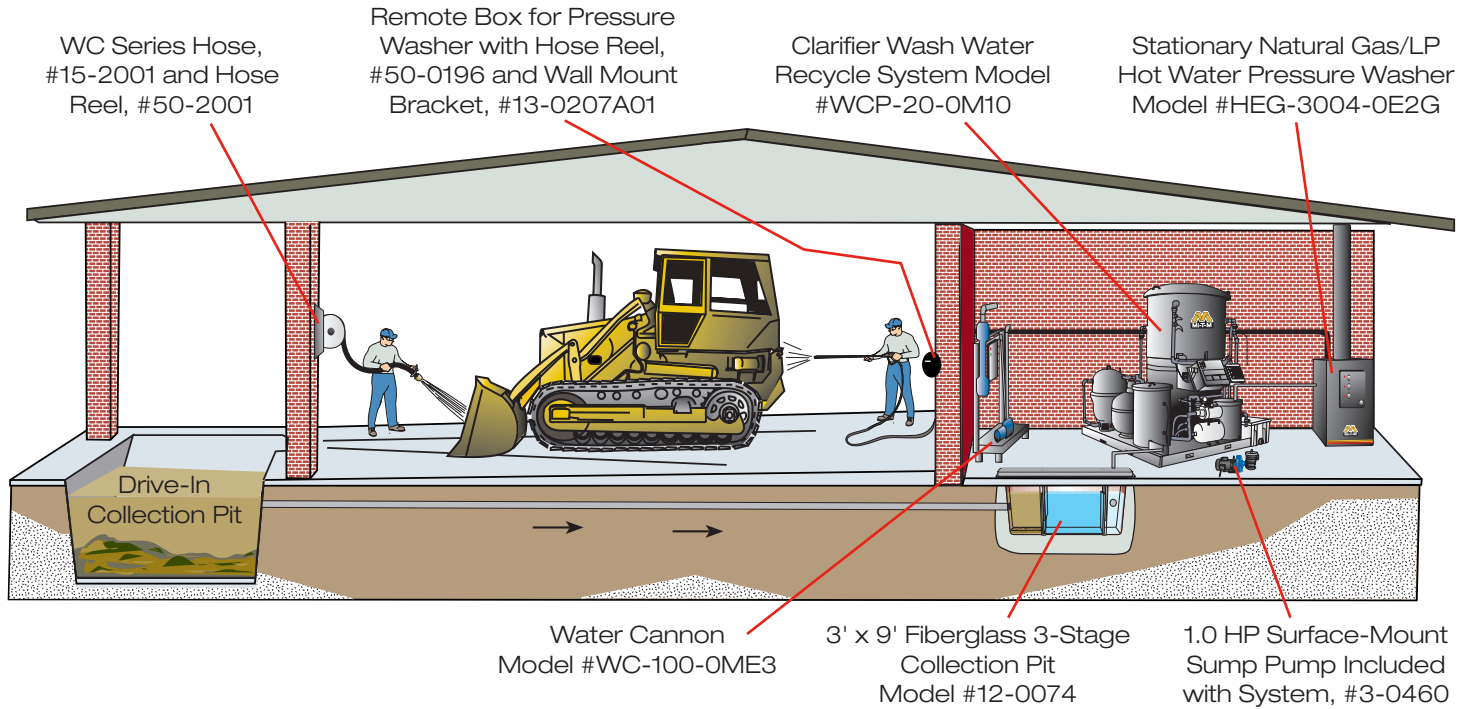

RECOMMENDED APPLICATIONS:

- Rental Yards
- Golf Courses
- Heavy Equipment Dealers
- Trucking Facilities
- Military Bases
- Truck Rental Fleets
- Diesel Repair Facilities
- Forklift Washing Operations
- Aircraft Maintenance and Restoration
- Shipyards
- Municipalities/State DOTs
- Oil Fields
- Engine Rebuilders and Manufacturers

THE IMPORTANCE OF A PROPER PIT SYSTEM:

Once equipment is washed, the untreated wash water flows into your pit system. A proper pit system for your application is the first step in proper wash water treatment and a critical element in any wash water recycle system.

Consult your dealer to determine the pit system configuration that works best for your application.

WCPB SERIES

- Special-build model
- WCPB Series allows the end user to switch from a mechanical filtration unit to a biological unit depending on certain factors. The unit may be changed depending on the time of year, temperature, contaminants in water pH or other factors.
- Contact your dealer for more information



WLP & WCP Series

Replacement Filter Element & Media

REPLACEMENT FILTER ELEMENT

| PART NUMBER | DESCRIPTION | FITS MODELS |
|-------------|--|-----------------|
| 19-0264 | Filter – Replacement filter for #19-0630, 30-micron, 400 sq. ft., 3 filters needed | WLP-20 & WCP-20 |



Filter, 19-0264

REPLACEMENT MEDIA

Order per pound

| PART NUMBER | DESCRIPTION |
|-------------|--|
| 33-0302 | Activated carbon |
| 33-0303 | Gravel #3 |
| 33-0304 | Garnet #12 |
| 33-0305 | Garnet #50 |
| 33-0306 | Filter ag |
| 33-0318 | Organoclay – Custom media |
| 33-0403 | Garnet #80 |
| 33-0450 | Zeolites – Custom media, best for red clay, 50 lb. bag |



Activated Carbon



Gravel #3



Garnet #12



Garnet #50



Filter Ag



Organoclay



Garnet #80

Mi-T-M[®]
EQUIPMENT
SALES & SERVICE

9872 Kapp Court | Peosta, IA 52068
 (800) 556-8866 | (563) 556-8866
www.mitmequipmentsales.com