



OPERATORS MANUAL FOR Mi-T-M®  
***BIOLOGICAL PIT MANAGEMENT SYSTEM***  
***BPS-120M***



CAUTION  
RISK OF INJURY!

READ MANUAL BEFORE OPERATING!

This manual is an important part of the Biological Pit Management System and must remain with the unit when you sell it!

# CONTENTS

INTRODUCTION .....	3
PURPOSE .....	4
SPECIFICATIONS .....	4
CONTENTS OF BIOLOGICAL PIT MANAGEMENT SYSTEM .....	4
IMPORTANT SAFETY WARNINGS .....	5
FEATURES .....	8
FLOW CHART .....	9
INSTALLATION .....	10
ATTIRE .....	10
PREPARATION .....	11
SETTING THE TIMERS .....	11
TROUBLESHOOTING .....	12
REPLACEMENT PARTS .....	12
ASSEMBLY .....	13
STATEMENT OF WARRANTY .....	14

## **WARNING**

 **WARNING:** This product can expose you to chemicals including Lead, which is known to the State of California to cause cancer and birth defects or other reproductive harm. For more information go to [www.P65Warnings.ca.gov](http://www.P65Warnings.ca.gov)

## **WARNING**

 **WARNING:** This product can expose you to chemicals including carbon monoxide, which is known to the State of California to cause birth defects or other reproductive harm. For more information go to [www.P65Warnings.ca.gov](http://www.P65Warnings.ca.gov)

## INTRODUCTION

Congratulations on the purchase of your new Mi-T-M Biological Pit Management System (BPS). You can be assured your Mi-T-M Biological Pit Management System (BPS) was constructed and designed with quality and performance in mind. Each component has been rigorously tested to ensure the highest level of acceptance.

This operator's manual was compiled for your benefit. By reading and following the simple safety, installation, operation, maintenance and troubleshooting steps described in this manual, you will receive years of trouble free operation from your new Mi-T-M BPS System. The contents of this manual are based on the latest product information available at the time of publication. Mi-T-M reserves the right to make changes in price, color, materials, equipment, specifications or models at any time without notice.

### **! IMPORTANT !**

**ALWAYS PROVIDE A COPY OF THIS MANUAL TO ANYONE USING THIS EQUIPMENT. READ ALL INSTRUCTIONS BEFORE USING THIS BIOLOGICAL PIT MANAGEMENT SYSTEM AND ESPECIALLY POINT OUT THE "SAFETY WARNINGS" TO PREVENT THE POSSIBILITY OF PERSONAL INJURY TO THE OPERATOR.**

Once the unit has been uncrated, inspect for signs of obvious or concealed freight damage. If damage does exist, file a claim with the transportation company immediately. Be sure that all damaged parts are replaced and that the mechanical and electrical problems are corrected prior to operation of the unit. If you require service, contact Mi-T-M Customer Service.

#### CUSTOMER SERVICE

CALL OUR TOLL-FREE NUMBER

for the Sales or Service Center nearest you!

800-553-9053

Please have the following information available for all service calls:

1. Model Number
2. Serial Number
3. Date and Place of Purchase

## PURPOSE

The Mi-T-M Biological Pit Management System is designed to offer an economical and environmentally safe solution to remediate waste water in an existing pit system. The Biological Pit Management System gives you the ability to aerate your pits and inject environmentally friendly bacteria to remove industrial waste from your process water. Mi-T-M utilizes bacteria that are naturally occurring (not genetically enhanced) and will not cause disease.

Mi-T-M has been involved in water products since the early seventies and our commitment to quality is passed on to our customers. But our commitment to the environment is passed on to our children.

## SPECIFICATIONS

<b>MODEL</b>	<b>BPS-120M</b>
ELECTRICAL	120V, 1H, 8 AMP, 60 HZ
LINEAR AIR PUMP (CFM)	3 - EACH PUMP
PERISTALTIC PUMP (ML/MIN)	48 / EACH PUMP
WEIGHT (LBS)	150
DIMENSIONS (L X W X H)	30" X 22" X 39"

## CONTENTS OF BIOLOGICAL PIT MANAGEMENT SYSTEM

Carefully unpack your new Mi-T-M Biological Pit Management System. Check the contents against the packing list. Contact the freight line if damage claim is required on and component. The following items are the basic equipment sent with your Biological Pit Management System:

1. Biological Pit Management Cabinet
  - a. Linear Air Pumps (qty 2)
  - b. Peristaltic Pumps (qty 2)
  - c. Control Timers (qty 2)
2. Rubber Air Hose with Check Valve (qty 2)
3. Air Stones (qty 2)
4. Chemical Feed Lines (for bacteria/nutrient injection) (qty 2)



# IMPORTANT SAFETY WARNINGS







HAZARD	POTENTIAL CONSEQUENCE	PREVENTION
<p data-bbox="180 268 532 327"><b>RISK OF ELECTRIC SHOCK OR ELECTROCUTION</b></p> 	<p data-bbox="558 268 971 485">Serious injury or death could occur if the Biological Pit Management System is not properly grounded. Your Biological Pit Management System is powered by electricity and may cause electric shock or electrocution if not installed properly.</p> <p data-bbox="558 1087 971 1171">Electrical shock may occur if Biological Pit Management System is not operated properly.</p> <p data-bbox="558 1325 971 1409">Serious injury or death may occur if electrical repairs are attempted by unqualified persons.</p>	<p data-bbox="997 268 1528 352">Installation of this unit, including all electrical connections, must comply with all local, state and national codes.</p> <p data-bbox="997 369 1528 541">This product must be grounded. Connect to a GFCI circuit breaker when available. If the unit should malfunction or breakdown, grounding provides a path of least resistance for electric current to reduce the risk of electric shock. Do not ground to a gas supply line.</p> <p data-bbox="997 558 1528 705">Improper connection of the equipment-grounding conductor can result in a risk of electrocution. Check with a qualified electrician or service personnel if you are in doubt as to whether the system is properly grounded.</p> <p data-bbox="997 722 1528 869">Always be certain the unit is receiving proper voltage (+/- 5% of the voltage listed on the nameplate). Before installing electrical connections, be certain the power switches are in the "OFF" position.</p> <p data-bbox="997 886 1528 907">Keep all connections dry and off the ground.</p> <p data-bbox="997 1104 1528 1188">DO NOT allow metal components of the Biological Pit Management System to come in contact with live electrical components.</p> <p data-bbox="997 1205 1528 1318">Never operate the Biological Pit Management System with safety guards/covers removed or damaged. Ensure all electrical covers are securely in place when unit is operating.</p> <p data-bbox="997 1335 1528 1482">Any electrical wiring or repairs performed on this Biological Pit Management System should be done by Authorized Service Personnel in accordance with National and Local electrical codes.</p> <p data-bbox="997 1499 1528 1843">Before opening any electrical enclosure, always shut off the Biological Pit Management System and drain the water. Disconnect the Biological Pit Management System from the power source. If the power disconnect is not in sight, lock it in the open position and tag it to prevent power usage. (Never assume the Biological Pit Management System is safe to work on just because it is not operating, it could restart at any time! Always disconnect from the power source.) Allow the Biological Pit Management System components to cool down.</p>

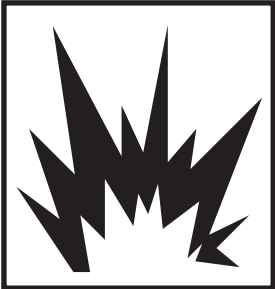

# IMPORTANT SAFETY WARNINGS





HAZARD	POTENTIAL CONSEQUENCE	PREVENTION
<p data-bbox="103 233 487 260"><b>RISK OF EXPLOSION OR FIRE</b></p>  	<p data-bbox="511 226 920 317">Serious injury or death could occur from an explosion or fire caused by a system electric spark.</p>	<p data-bbox="950 226 1477 348">This unit must be placed in an area that is well ventilated, free of flammable vapors, combustible dust, gases or other combustible materials.</p>
<p data-bbox="170 919 423 947"><b>RISK OF BURSTING</b></p> 	<p data-bbox="511 919 920 1010">Serious injury or death could occur from bursting caused by excessive pressure in the system.</p> <p data-bbox="511 1434 920 1556">Serious injury may occur if attempting to start the Biological Pit Management System when the chemical or air lines are frozen.</p>	<p data-bbox="950 919 1477 1152">Do not mistreat the pressure gauges on the system. Pressure gauges will malfunction if they are subjected to excessive pressure, vibration, pulsation or temperature or if they are placed in an environment which causes corrosion of parts. Incorrect readings on a pressure gauge could mislead the operator and place him in a dangerous working condition.</p> <p data-bbox="950 1169 1477 1283">Do not use this Biological Pit Management System to pump flammable material! An explosion could occur from a gas vapor buildup inside the system.</p> <p data-bbox="950 1434 1477 1604">In freezing temperatures, the unit must always be warm enough to ensure there is no ice formation in the lines. Do not start the Biological Pit Management System if it has been in a freezing environment without first allowing the lines to thaw.</p>
<p data-bbox="193 1644 401 1671"><b>RISK OF BURNS</b></p> 	<p data-bbox="511 1640 894 1822">Serious injury may occur from touching the electrical motor. This area can remain hot for some time after the Biological Pit Management System is shutdown.</p>	<p data-bbox="950 1640 1471 1692">Never allow any part of your body to contact the electrical motor until cooled.</p>



# IMPORTANT SAFETY WARNINGS



HAZARD	POTENTIAL CONSEQUENCE	PREVENTION
<p><b>RISK FROM MOVING PARTS</b></p> 	<p>Serious injury may occur to the operator from moving parts on the Biological Pit Management System.</p>	<p>Do not operate the unit without all protective covers in place.</p> <p>Follow the maintenance instructions specified in the manual.</p>
<p><b>RISK OF BODILY INJURY</b></p> 	<p>Injury may occur from the Biological Pit Management System.</p>	<p><b>DO NOT DRINK THE WATER TREATED BY THE BIOLOGICAL PIT MANAGEMENT SYSTEM!!</b> This is non-potable water and is not suitable for consumption.</p> <p><b>DO NOT</b> allow children to operate this unit.</p> <p><b>DO NOT</b> overreach or stand on unstable support.</p> <p>Wet surfaces can be slippery, wear protective foot gear and keep good footing and balance at all times.</p> <p>Know how to stop the Biological Pit Management System. Be thoroughly familiar with controls.</p> <p>Before servicing components, <b>ALWAYS</b> shut off the Biological Pit Management System.</p> <p>Consult Material Safety Data Sheets (MSDS) for safe handling of system, especially bacteria and nutrients.</p>



**!SAVE THESE INSTRUCTIONS!**



# FEATURES

BPS-120M FEATURES 020419 MLT

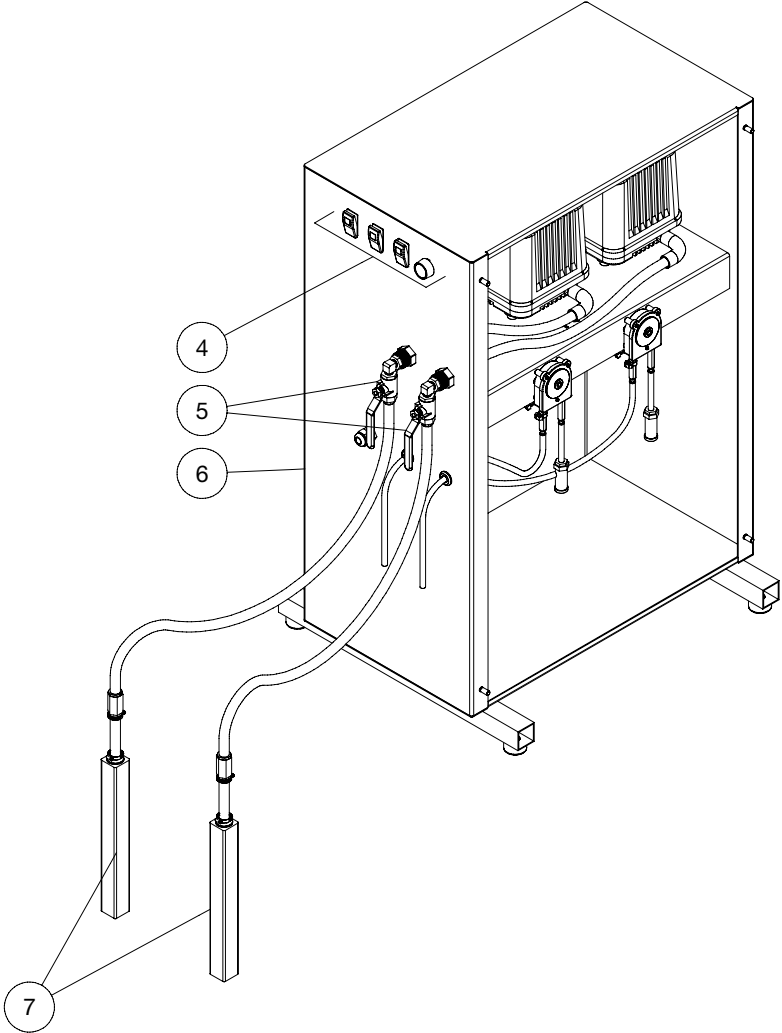
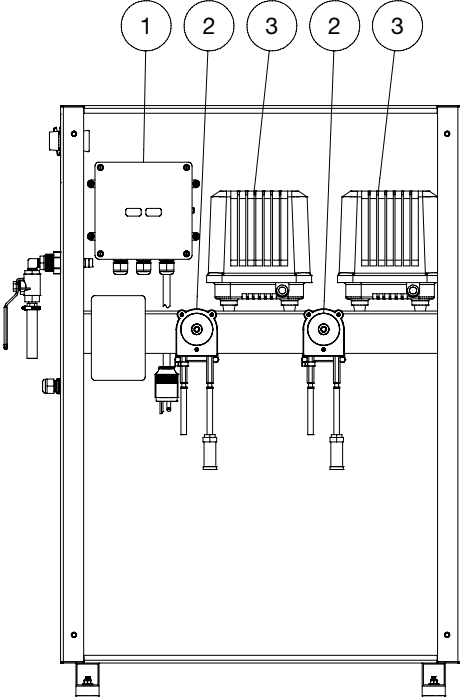

- 1. Control Timer Housing
- 2. Peristaltic Pump
- 3. Linear Air Pump
- 4. Power/Control Switches
- 5. Airflow Control Valves
- 6. BPS Cabinet
- 7. Air Stones



## FLOW CHART

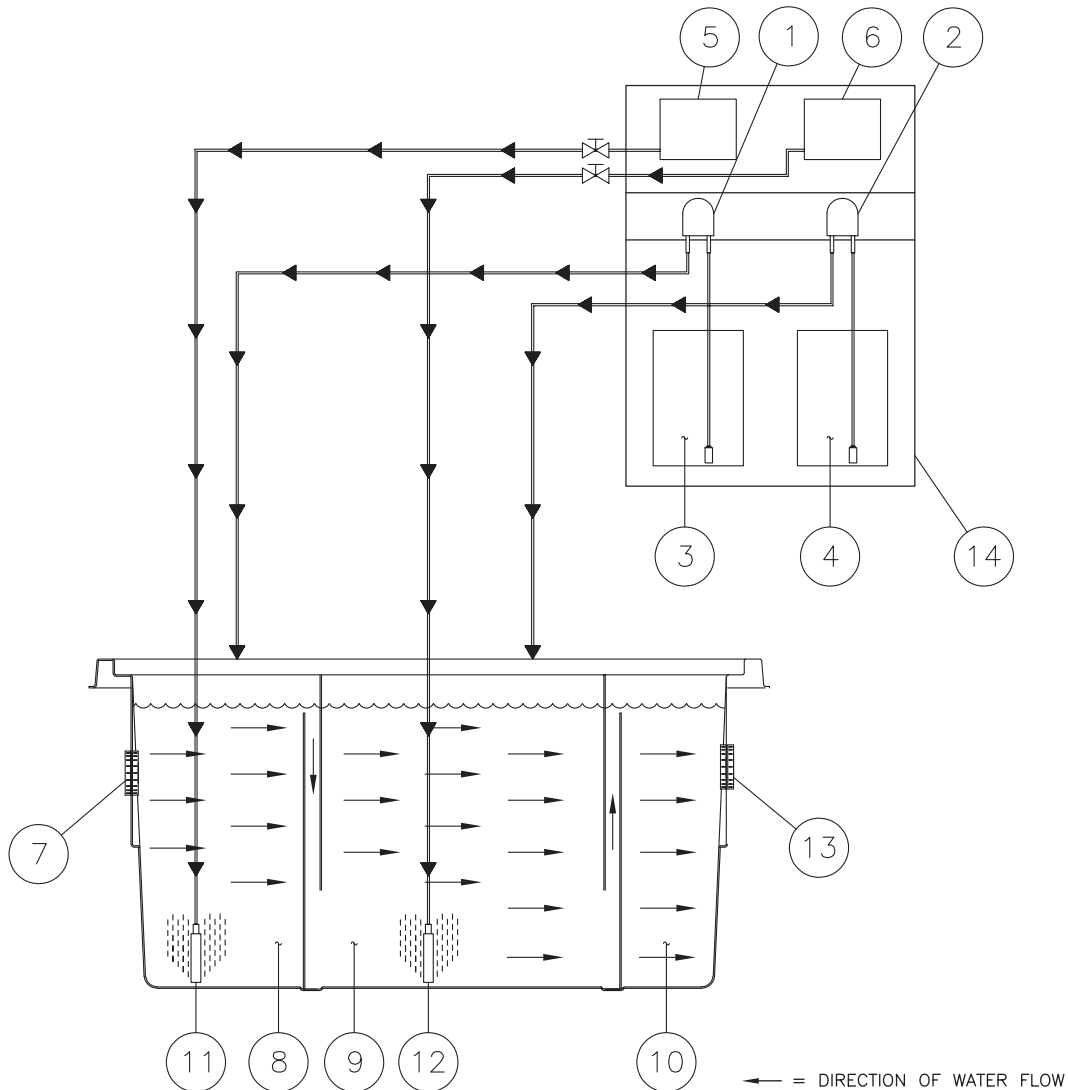

Housed inside a **Control Cabinet (14)** are two **Peristaltic Pumps (1&2)** and two **Air Pumps (5&6)**. **Liquid Bacteria (3)** and **Bio Enhancer Nutrient (4)** are fed through **Peristaltic Pumps (1&2)** into an in-ground pit or water storage vessel. Air from the **Air Pumps (5&6)** is pumped through **Ceramic Air Stones (11&12)** and into the waste water providing an aerobic environment for the bacteria to digest contaminants. As waste water flows into the **First Chamber (8)** of a three stage pit through the **Pit Inlet (7)** it comes into contact with the air and bacteria starting the digestion process. Then the water flows into the **Second Chamber (9)** and is treated with bacterial nutrients and more air which aids in bacteria reproduction and further digestion of water contaminants. The cleaned water then flows into the **Final Chamber (10)** and is discharged through the **Pit Outlet (13)** for further treatment or disposal to sanitary sewer.

## INSTALLATION

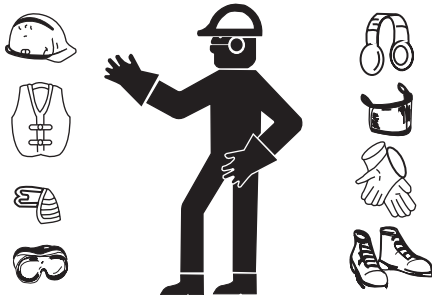

### ATTIRE:

Proper attire is essential to your safety. It is advised to utilize whatever means necessary to protect eyes, ears and Skin.

### INSTALLATION:

1. A collection Pit System must all ready be an established structure before installing the Biological Pit Management System. A well designed pit system is critical to the proper operation of the Biological Pit Management System. Consult your Mi-T-M dealer for instillation requirements.
2. Place the Biological Pit Management System on a hard, level surface in an area free of flammable vapors, combustibile dust, gases or other combustibile materials.
3. Arrange the system so you have access to the components inside the cabinet as well as the controls on the side of the cabinet.
4. Do not place unit in an area:
  - With insufficient ventilation.
  - Where environmental hazards (i.e. rain & snow) can come in contact with the Biological Pit Management System.
  - Where temperatures will be below 60 degrees Fahrenheit or above 120 degrees Fahrenheit because it will make the bacteria ineffective.
5. Attach all hose (air & chemical) to their respective hose barb. Open control valves for the air stones so linear air pumps can start with no load on the pumps.
6. Install the air stones into the pit at equal distance from each other and the walls to insure proper aeration of the waste water.
7. Run the chemical feed hoses to the location where you want the bacteria to be injected to begin breaking down the waste water.
8. Place the buckets of bacteria into the Biological Pit Management System's cabinet and place strainer side of chemical feed hoses into the buckets.
9. Set the timers to turn aeration on and actuate pumps to inject bacteria for required amount of time. See "Setting the Timers".
10. Plug Biological Pit Management System into a 120VAC outlet.

# PREPARATION

## SETTING THE TIMERS:



**WARNING**  
**RISK OF ELECTROCUTION!**  
**MAKE SURE ALL POWER TO THE UNIT IS TURNED OFF WHEN WORKING ON COMPONENTS IN THE CONTROL PANEL.**

### ELECTRONIC TIMER:

A simple Phillips head screwdriver can be used to make the adjustment here. Available settings on both range setting adjustments are:

1 second, 3 seconds, 10 seconds, 1 minute, 3 minutes, 10 minutes, 1 hour, 3 hours, 10 hours, and 60 hours.

See example to the right. The time dials determine the percent value of the range settings from 0 to 1.0. As an example, if the range setting is at 10 hours, and the corresponding time dial is at 0.8, then the value for that function is 80% of 10 hours, or 8 hours.

Range setting/ timer dial setting one determines the frequency of the timer activation. The example is set to activate every 8 hours. Range setting/ timer dial setting two determines the duration of the timer activation. The example is set for 8 seconds. The slide switch should remain in the up position.

### RECOMMENDED SETTINGS:

The Timers will come from the factory set at the below settings.

**LINEAR AIR PUMP (Timer 1):** Cycle pump for 8 hours on and 10 minutes off.

- Set Time Dial 2 at .8 and Range Setting 2 at 10 h.
- Set Time Dial 1 at 1.0 and Range Setting 1 at 10 min.
- Set Up/Down Switch to up position.
- Will start off when powered.
- See Figure.

**MICROBE PUMP (Timer 2):** Recommend dosing bacteria 12oz total throughout the day. Pump rate is 48 ml/min (1.6 oz/min). Set pump to timer to run pump for 3 minutes every 10 hours, this will be approximately 12oz/day.

- Set Time Dial 2 at 1.0 and Range Setting 2 at 3 min.
- Set Time Dial 1 at 1.0 and Range Setting 1 at 10 h.
- Set Up/Down Switch to up position.
- Will start off when powered.
- See Figure.

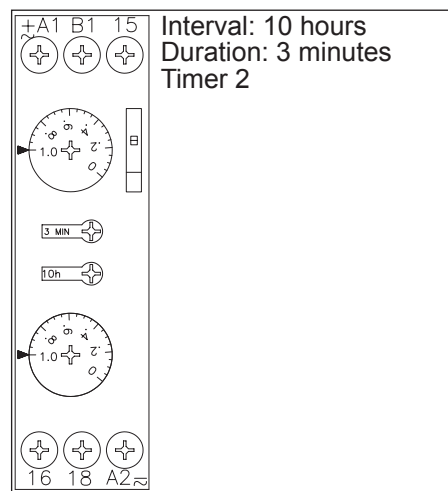
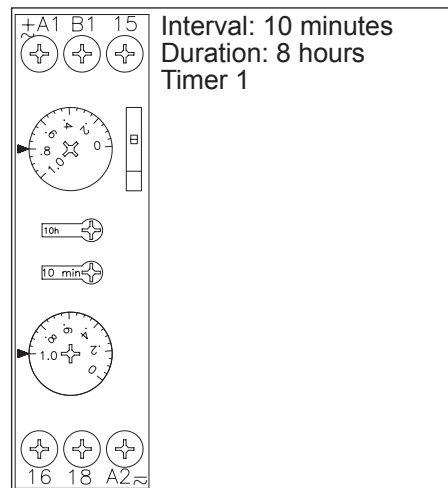
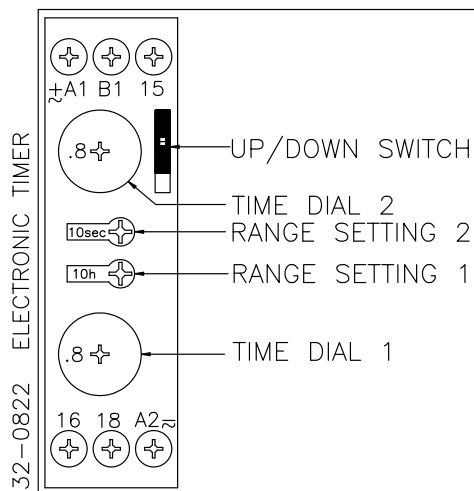

## TROUBLESHOOTING

Symptom	Probable Cause	Solution
Air pumps/peristaltic pumps do not turn on.	BPS Unit is not plugged in.	Plug the unit into a 120V receptacle.
	Master power switch is in the off position.	Turn on the Master power switch.
	Timer is not allowing pumps to turn on.	Evaluate timer settings and determine if it is allowing the pumps to run enough time.
Air pumps are on but no air is being supplied to the pit.	Air lines are not connected correctly.	Insure air lines are all hooked up correctly and check valve is facing the right direction.
	Flow control valves are closed.	Open valves until an appropriate amount of air is flowing to the pit.
	Air stones are plugged	Inspect air stones for porosity and replace if necessary.
Excessive bacteria usage.	Timer is set incorrectly.	Make sure timer is set correctly and reduce amount of time on if necessary.
Bacteria not being fed to the pits.	Filter screen in bacteria bucket is plugged.	Inspect filter screen and clean or replace if necessary.
	Chemical line has split somewhere.	Inspect chemical feed lines and replace if they are damaged.

## REPLACEMENT PARTS

<b>DESCRIPTION</b>	<b>REORDER#</b>
Dry Microbes-Hydrocarbon/VOC mix .....	RC-2001-0001
Dry Microbes-Golf Course Mix .....	RC-2002-0001
Dry Microbes-Fats, Oil and Grease .....	RC-2003-0001
Test Strips.....	33-0314
Liquid microbes-Hydrocarbon-5 gallon pail .....	AW-0058-0001

# ASSEMBLY

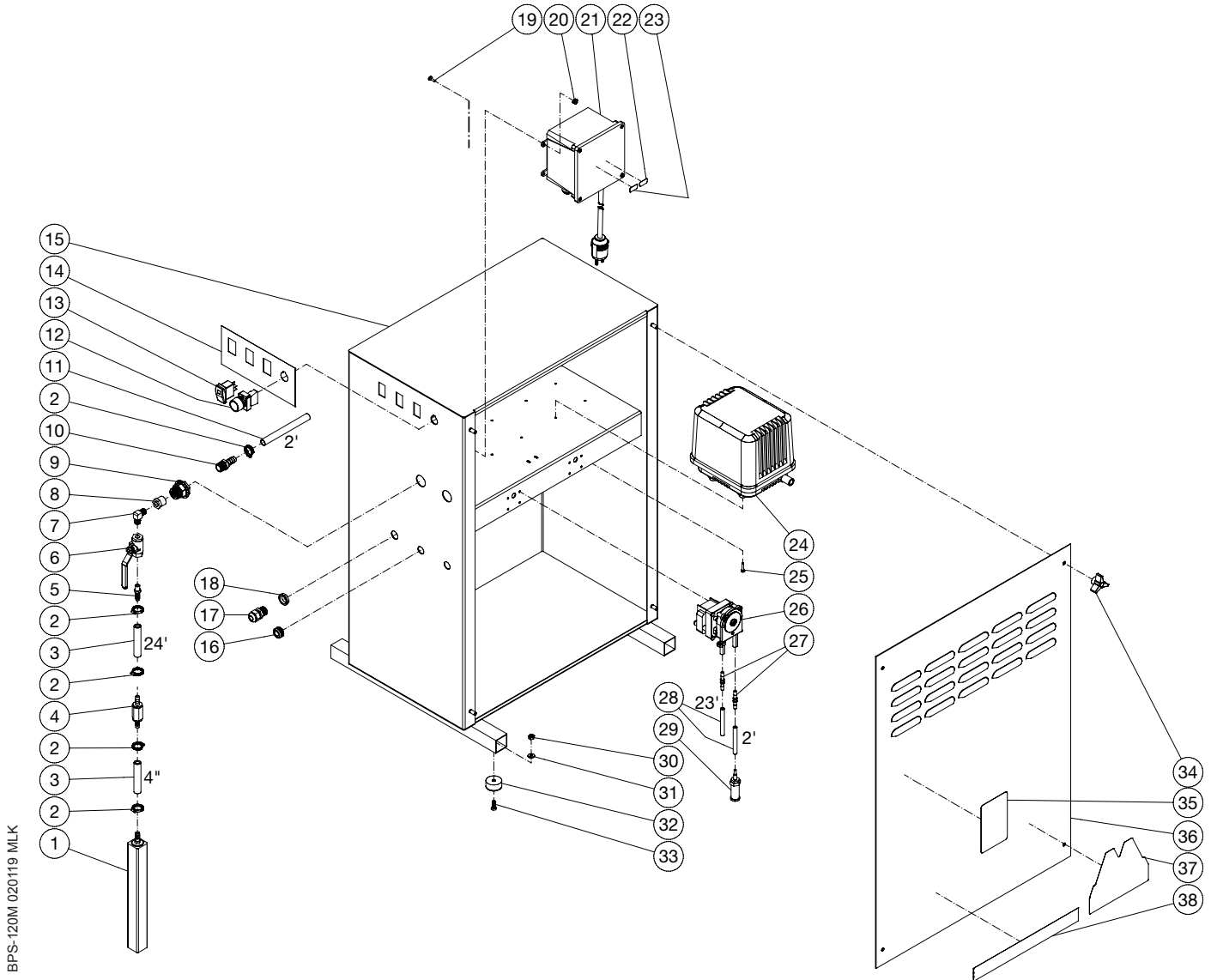

BPS-120M 020119 MLK

FRAME ASSEMBLY				BPS-120M 020119 MLK			
ITEM	DESCRIPTION	Mi-T-M #	QTY	ITEM	DESCRIPTION	Mi-T-M #	QTY
1	AIR STONE	33-0447	2	21	CONTROL BOX ASSEMBLY	N/A SEP	1
2	HOSE CLAMP	42-0011	10	22	DECAL - 1 PHASE (SEE 71-0111)	N/A	1
3	HOSE *(FIFTY FEET REQUIRED)	15-0020	1	23	DECAL - 115 VOLT (SEE 71-0111)	N/A	1
4	CHECK VALVE	22-0399	2	24	AIR PUMP	3-0327	2
5	BARB	23-0069	2	25	BOLT	27-8930	8
6	BALL VALVE	22-0002	2	26	PUMP	3-0316	2
7	ELBOW	23-0130	2	29	STRAINER	19-0056	2
8	REDUCER	23-0056	2	27	HOSE MENDER	55-0022	4
9	ADAPTER	23-0365	2	28	HOSE *(FIFTY FEET REQUIRED)	15-0021	1
10	BARB	23-0045	2	30	LOCKNUT	30-0155	4
11	HOSE *(FOUR FEET REQUIRED)	15-0026	1	31	WASHER	28-0002	4
12	SWITCH PUSH BUTTON	32-0534	1	32	ISOLATOR	14-0069	4
13	SWITCH	32-0771	3	33	BOLT	27-0015	4
14	DECAL - BPS CONTROLS (SEE 71-0111)	N/A	1	34	KNOB	7-0204	4
15	CABINET	20-1170A18	1	35	DECAL - RISK OF ELECTROCUTION (SEE 71-0111)	N/A	1
16	GROMMET	33-0001	2	36	DOOR	20-1171A18	1
17	STRAIN RELIEF	32-0437	1	37	DECAL - Mi-T-M	34-2170	1
18	ELECTRICAL LOCKNUT	32-0108	1	38	DECAL - 17" STRIPE	34-2187	1
19	SCREW	27-5033	4	-	DECAL SET	71-0111	1
20	NUT	30-9516	4				

\*MUST ORDER IN ONE FOOT LENGTHS

## PUMP (3-0316)

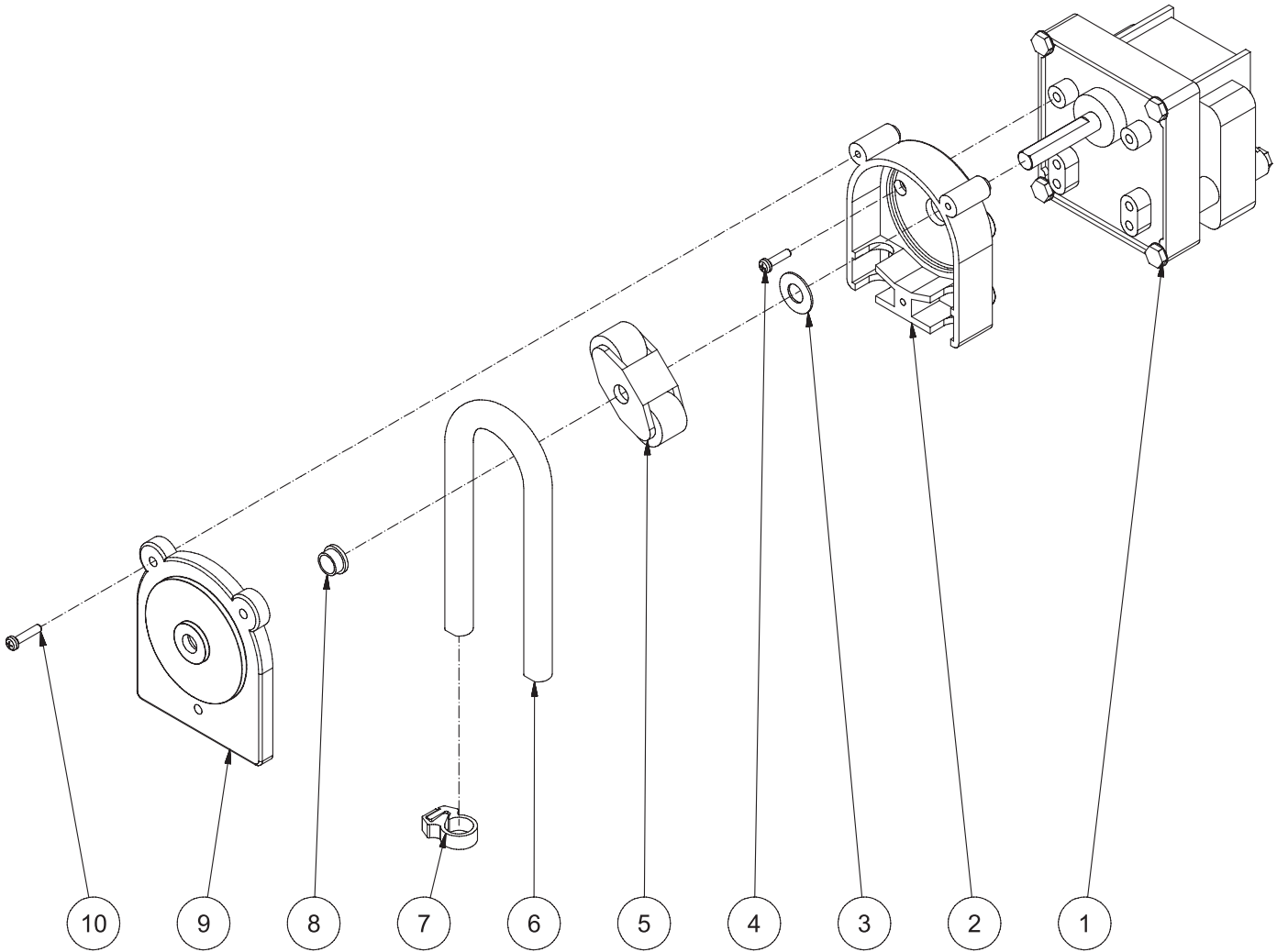

3-0316 030110-PJH

3-0316 030110-PJH			
PUMP (3-0316)			
ITEM	DESCRIPTION	PART #	QTY
1	MOTOR	N/A	1
2	HOUSING (SEE 70-0245)	N/A	1
3	WASHER	N/A	1
4	SCREW	27-2771	4
5	ROLLER BRACKET ASSEMBLY	46-0830	1
6	TUBE	15-0205	1
7	CLAMP	42-0028	1
8	BUSHING	9-0080	1
9	PUMP COVER (SEE 70-0245)	N/A	1
10	SCREW (SEE 70-0245)	N/A	3
-	PH/OPR PUMP KIT (INC. 2, 3, 4, 8, 9, 10)	70-0245	1

# CONTROL BOX ASSEMBLY

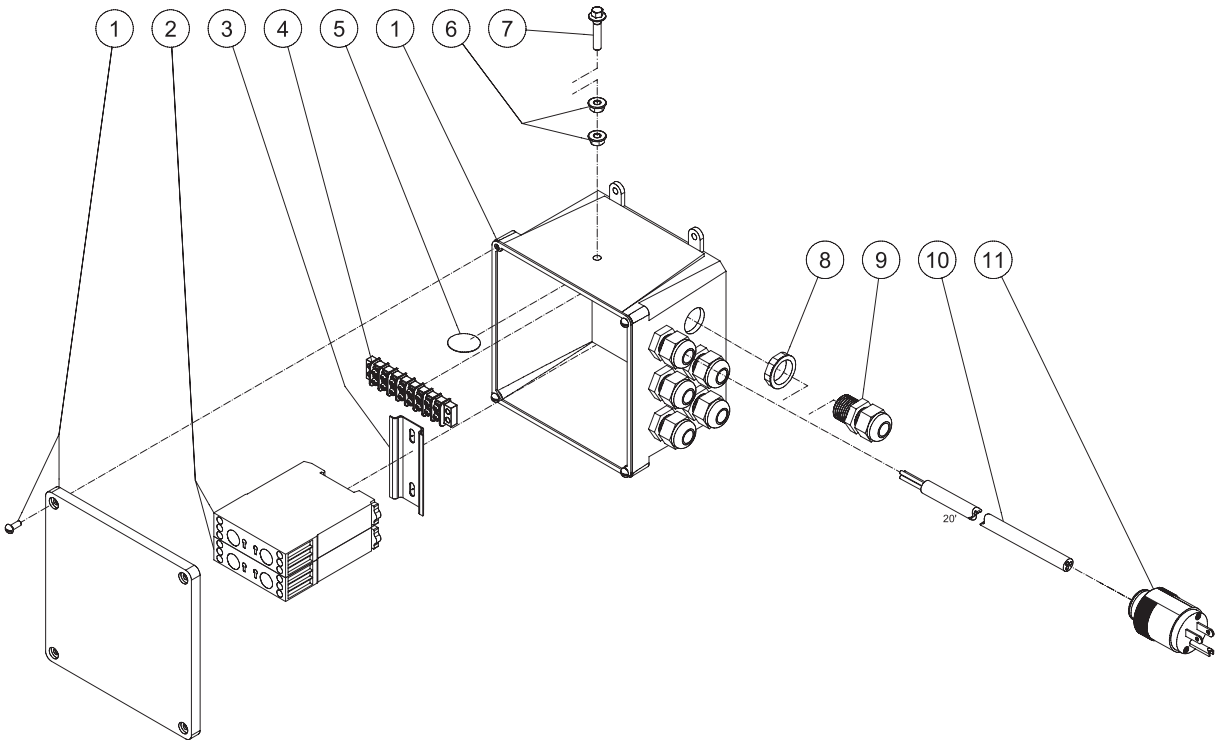

CONTROL BOX ASSEMBLY BPS-120M 031113 MLK

CONTROL BOX ASSEMBLY- BPS120M 031113 MLK			
CONTROL BOX ASSEMBLY			
ITEM	DESCRIPTION	Mi-T-M #	QTY
1	CONTROL BOX	32-0702	1
2	RELAY TIMER	32-0822	2
3	DIN RAIL *(ONE FOOT REQUIRED)	32-0316	1
4	TERMINAL STRIP	32-0436	1
5	DECAL- GROUND PICTORIAL (SEE 71-0111)	N/A	1
6	NUT	30-3022	2
7	BOLT	27-8898	1
8	ELECTRICAL LOCKNUT	32-0108	6
9	STRAIN RELIEF	32-0437	6
10	CORD *(TWENTY FEET REQUIRED)	32-0074	1
11	PLUG	32-0026	1
-	DECAL SET	71-0111	1
*MUST ORDER IN ONE FOOT LENGTHS			



## STATEMENT OF WARRANTY

Mi-T-M warrants all parts (except those referred to below) of your new Biological Pit Management System to be free from defects in materials and workmanship for One (1) Year from the date of original purchase.

Defective parts not subject to normal wear and tear will be repaired or replaced at Mi-T-M's option during the warranty period which upon examination is disclosed to have been defective in material or workmanship. In any event, reimbursement is limited to the purchase price paid.

### EXCLUSIONS

1. This warranty does not cover parts damaged due to:
  - normal wear, misapplication, modifications/alterations, abuse, -operation at other than recommended speeds, pressures or temperature,
  - the use of caustic liquids,
  - chloride corrosion or chemical deterioration,
  - fluctuations in electrical or water supply,
  - operating unit in an abrasive, corrosive or freezing environment.
2. This warranty does not cover parts damaged by failure to follow recommended installation, operating and maintenance procedures.
3. This warranty does not cover the cost of:
  - normal maintenance or adjustments,
  - labor charges,
  - transportation charges to Service Center,
  - freight damage.
4. The use of other than genuine Mi-T-M parts will void warranty. Parts returned, prepaid to Mi-T-M's factory or to an Authorized Service Center will be inspected and replaced free of charge if found to be defective and subject to warranty. There are no warranties which extend beyond the description of the face hereof. Under no circumstances shall Mi-T-M bear any responsibility for loss of use of the unit, loss of time or rental, inconvenience, commercial loss or consequential damages.

For Service or Warranty consideration, contact  
Mi-T-M Corporation, 50 Mi-T-M Drive, Peosta, IA 52068-0050  
319-556-7484 / 800-553-9053 / Fax 319-556-1235  
Monday-Friday 7:30 AM - 5:00 PM CST





