



OPERATORS MANUAL FOR Mi-T-M®
WCL-10S/30S-0M10
CLARIFIER TYPE SOLIDS SEPARATOR



CAUTION
RISK OF INJURY!

READ MANUAL BEFORE OPERATING!

This manual is an important part of the water treatment system and must remain with the unit when you sell it!

TABLE OF CONTENTS

INTRODUCTION	3
CONTENTS OF WCL-SERIES WATER TREATMENT SYSTEM	4
SPECIFICATIONS	4
IMPORTANT SAFETY WARNINGS	5-7
RISK OF ELECTRIC SHOCK OR ELECTROCUTION	5
RISK OF EXPLOSION OR FIRE	6
RISK OF BURSTING	6
RISK OF BURNS	6
RISK FROM MOVING PARTS	7
RISK OF BODILY INJURY	7
FLOW CHART	8-9
FEATURES	10
INSTALLATION	11-12
PREPARATION	13
PRE-OPERATION CHECKLIST	13
PRE-START PROCEDURES	13
START-UP	13
OPERATION	14
MAINTENANCE	14-15
WASTE OIL DECANter	14
SLUDGE TUB OPERATION	15
WINTERIZING	15
TROUBLESHOOTING	16-17
STATEMENT OF WARRANTY	18

WARNING

 **WARNING:** This product can expose you to chemicals including Lead, which is known to the State of California to cause cancer and birth defects or other reproductive harm. For more information go to www.P65Warnings.ca.gov

WARNING

 **WARNING:** This product can expose you to chemicals including carbon monoxide, which is known to the State of California to cause birth defects or other reproductive harm. For more information go to www.P65Warnings.ca.gov

INTRODUCTION

Congratulations on the purchase of your new Mi-T-M water treatment system! You can be assured your Mi-T-M water treatment system was constructed and designed with quality and performance in mind. Each component has been rigorously tested to ensure the highest level of acceptance.

This operator's manual was compiled for your benefit. By reading and following the simple safety, installation, operation, maintenance and troubleshooting steps described in this manual, you will receive years of trouble free operation from your new Mi-T-M water treatment system. The contents of this manual are based on the latest product information available at the time of publication. Mi-T-M reserves the right to make changes in price, color, materials, equipment, specifications or models at any time without notice.

! IMPORTANT !

These paragraphs are surrounded by a "SAFETY ALERT BOX". This box is used to designate and emphasize Safety Warnings that must be followed when operating this water treatment system.

Accompanying the Safety Warnings are "signal words" which designate the degree or level of hazard seriousness. The "signal words" used in this manual are as follows:

DANGER: Indicates an imminently hazardous situation which, if not avoided, **WILL** result in death or serious injury.

WARNING: Indicates a potentially hazardous situation which, if not avoided, **COULD** result in death or serious injury.



CAUTION: Indicates a potentially hazardous situation which, if not avoided **MAY** result in minor or moderate injury.



The symbols set to the left of this paragraph are "Safety Alert Symbols". These symbols are used to call attention to items or procedures that could be dangerous to you or other persons using this equipment.



ALWAYS PROVIDE A COPY OF THIS MANUAL TO ANYONE USING THIS EQUIPMENT. READ ALL INSTRUCTIONS BEFORE OPERATING THIS WATER TREATMENT SYSTEM AND ESPECIALLY POINT OUT THE "SAFETY WARNINGS" TO PREVENT THE POSSIBILITY OF PERSONAL INJURY TO THE OPERATOR.



Once the unit has been uncrated, immediately write in the serial number of your unit in the space provided below.

SERIAL NUMBER _____

Inspect for signs of obvious or concealed freight damage. If damage does exist, file a claim with the transportation company immediately. Be sure that all damaged parts are replaced and that the mechanical and electrical problems are corrected prior to operation of the unit. If you require service, contact Mi-T-M Customer Service.

CUSTOMER SERVICE
CALL OUR TOLL-FREE NUMBER
for the Sales or Service Center nearest you!
800-553-9053

Please have the following information available for all service calls:

1. Model Number
2. Serial Number
3. Date and Place of Purchase

CONTENTS OF WCL-SERIES WATER TREATMENT SYSTEM

Carefully unpack your new Mi-T-M Clarifier Type Solids Separator. Check the contents against the packing list. Contact the freight line if a damage claim is required on any component. The following items are the basic equipment sent with your Clarifier Type Solids Separator.

- | | |
|---|---|
| <ol style="list-style-type: none"> 1. Unattached Float with Piggy Back Plug for Sump Pit 2. Claifier Type Solids Separator <ol style="list-style-type: none"> a. Clarifier Tank b. Tank Stand c. Sump Pump 3. Waste Oil Decanter 4. Sludge Tub 5. Sludge Hose 6. Manual | <p>Accessories:</p> <ul style="list-style-type: none"> 165 gallon product tank. 80 gallon product tank. Ladder and Mezzanine (for WCL-30S only.) |
|---|---|

SPECIFICATIONS

Model	WCL-10S-0M10	WCL-30S-0M10
Maximum Flow	10 GPM	30 GPM
Electrical	230 Volt 1 Phase 8 Amps	230 Volt 1 Phase 8 Amps
Sump Pump	1HP	1HP
Clarifier Capacity	300 Gallon	600 Gallon
Oil Coalescing Area	48 Square Feet	73 Square Feet
Waste Oil Decanter	25 Gallon	25 Gallon
Dimensions (LxWxH)	65" x 51" x 97"	76" x 60" x 104"
Net Dry Weight (Approx.)	500 lbs.	650 lbs.



IMPORTANT SAFETY WARNINGS

WARNING: When using this product, basic precautions should always be observed, including the following:
READ ALL SAFETY WARNINGS BEFORE USING WATER TREATMENT SYSTEM







HAZARD	POTENTIAL CONSEQUENCE	PREVENTION
<p>RISK OF ELECTRIC SHOCK OR ELECTROCUTION</p> 	<p>Serious injury or death could occur if the water treatment system is not properly grounded. Your water treatment system is powered by electricity and may cause electric shock or electrocution if not installed properly.</p> <p>Electrical shock may occur if water treatment system is not operated properly.</p> <p>Serious injury or death may occur if electrical repairs are attempted by unqualified persons.</p>	<p>Installation of this unit, including all electrical connections, must comply with all local, state and national codes.</p> <p>This product must be grounded. Connect to a GFCI circuit breaker when available. If the unit should malfunction or breakdown, grounding provides a path of least resistance for electric current to reduce the risk of electric shock. Do not ground to a gas supply line.</p> <p>Improper connection of the equipment-grounding conductor can result in a risk of electrocution. Check with a qualified electrician or service personnel if you are in doubt as to whether the system is properly grounded.</p> <p>Always be certain the unit is receiving proper voltage (+/- 5% of the voltage listed on the nameplate). Before installing electrical connections, be certain the power switches are in the "OFF" position.</p> <p>Keep all connections dry and off the ground.</p> <p>Do not touch pump, pump motor, discharge piping or water when the unit is connected to the power supply; regardless of whether the unit is operating correctly or experiencing an operation failure.</p> <p>DO NOT allow metal components of the water treatment system to come in contact with live electrical components.</p> <p>Never operate the water treatment system with safety guards/covers removed or damaged. Ensure all electrical covers are securely in place when unit is operating.</p> <p>Any electrical wiring or repairs performed on this water treatment system should be done by Authorized Service Personnel in accordance with National and Local electrical codes.</p> <p>Before opening any electrical enclosure, always shut off the water treatment system and drain the water. Disconnect the water treatment system from the power source. If the power disconnect is not in sight, lock it in the open position and tag it to prevent power usage. (Never assume the water treatment system is safe to work on just because it is not operating, it could restart at any time! Always disconnect from the power source.) Allow the water treatment system to cool down. Service in a clean, dry, flat area.</p>

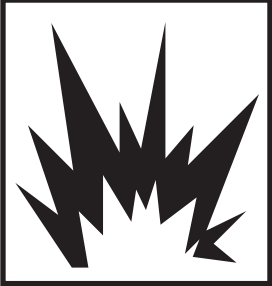

IMPORTANT SAFETY WARNINGS

READ ALL SAFETY WARNINGS BEFORE USING WATER TREATMENT SYSTEM

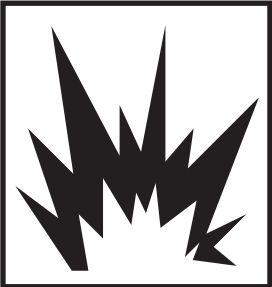

HAZARD	POTENTIAL CONSEQUENCE	PREVENTION
<p>RISK OF EXPLOSION OR FIRE</p>  	<p>Serious injury or death could occur from an explosion or fire caused by a system electric spark.</p>	<p>This unit must be placed in an area that is well ventilated, free of flammable vapors, combustible dust, gases or other combustible materials.</p>
<p>RISK OF BURSTING</p> 	<p>Serious injury or death could occur from bursting caused by excessive pressure in the system.</p> <p>Serious injury may occur if attempting to start the water treatment system when the pump is frozen.</p>	<p>Do not use this water treatment system to pump flammable material! An explosion could occur from a gas vapor buildup inside the system.</p> <p>In freezing temperatures, the unit must always be warm enough to ensure there is no ice formation in the pump. Do not start the water treatment system if it has been in a freezing environment without first allowing the pump to thaw.</p>
<p>RISK OF BURNS</p> 	<p>Serious injury may occur from touching the electrical motor. This area can remain hot for some time after the water treatment system is shutdown.</p>	<p>Never allow any part of your body to contact the electrical motor until cooled.</p>

WATER TREATMENT SYSTEM FLOW CHART

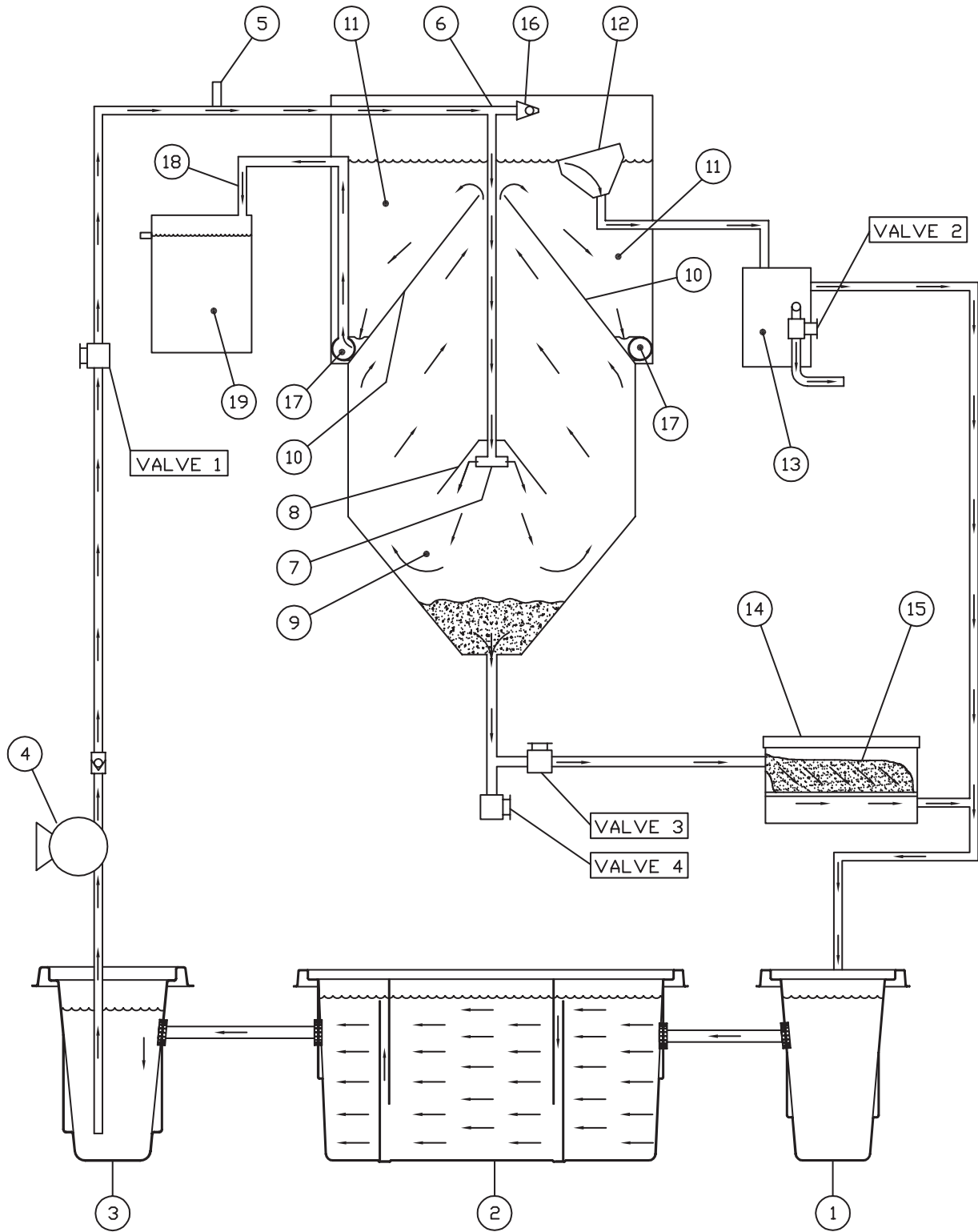

WCL-0023 072514 MLK

WATER TREATMENT SYSTEM FLOW CHART

As pressure washers are being operated, used water flows into the **Wash Water Catch Pit (1)**. From there, it moves to the **3-Stage Collection Pit (2)**. Heavy debris falls to the bottom of the pit where it is trapped by a weir which is designed to stop heavy debris while allowing the remaining water to move into the **Sump Pit (3)**. The **Sump Pump (4)** draws water from the **Sump Pit (3)** and brings it through the Water Inlet Flow Control Valve 1. This adjustable valve is used to regulate the flow of water entering the water clarification tank. A **Flow Meter (5)** is positioned just ahead of the clarifier tank. The water enters the water clarification tank through the **Inlet Tee (6)** and is directed down to the **Diverter Tee (7)**. From there the water is deflected downward by the **Solids Deflection Cone (8)**, then to the **Solids Separation Chamber (9)**. The **Solids Separation Chamber (9)** allows the velocity of the water to slow so that any suspended solids settle to the bottom. The water then rises up through the **Top Separator Cone (10)**.

- 1) The non-emulsified oil molecules in the water float to the surface of the **Oil Separation Chamber (11)**. The **Oil Skimmer (12)** is positioned near the top of the **Oil Separation Chamber (11)** which allows the thin layer of surface oil and water to drain into the **Waste Oil Decanter (13)**. Since oil is lighter than water, the oil floats to the top and is released from the **Waste Oil Decanter (13)** when the Waste Oil Release Valve 2 is opened. Excess water is returned to the **Wash Water Catch Pit (1)**.
- 2) The solids that accumulate in the bottom of the **Solids Separation Chamber (9)** should be regularly drained through the Solids Drain Valve 3 into the **Sludge Tub (14)** where the solids are filtered out and the water is returned to the **Wash Water Catch Pit (1)**. The **Filter Bag (15)** is biodegradable and may be tied off and disposed of as it is filled. If the solids accumulated at the bottom of the **Solids Separation Chamber (9)** are unable to drain, the Clean Out Valve 4 may be accessed to break the accumulation free.
- 3) An **Anti-siphon Device (16)** is attached to the **Inlet Tee (6)** to relieve any suction that may develop when the **Sump Pump (4)** is turned off, preventing any siphoning of water back out of the water clarification tank.

Water then flows from the **Oil Separation Chamber (11)** through the **Outlet Ring (17)** and into the **Outlet Tee (18)**. The **Outlet Tee (18)** directs the water to discharge or into the **Product Tank (optional) (19)** where it is held for further treatment.

FEATURES FOR WCL-10S AND WCL-30S

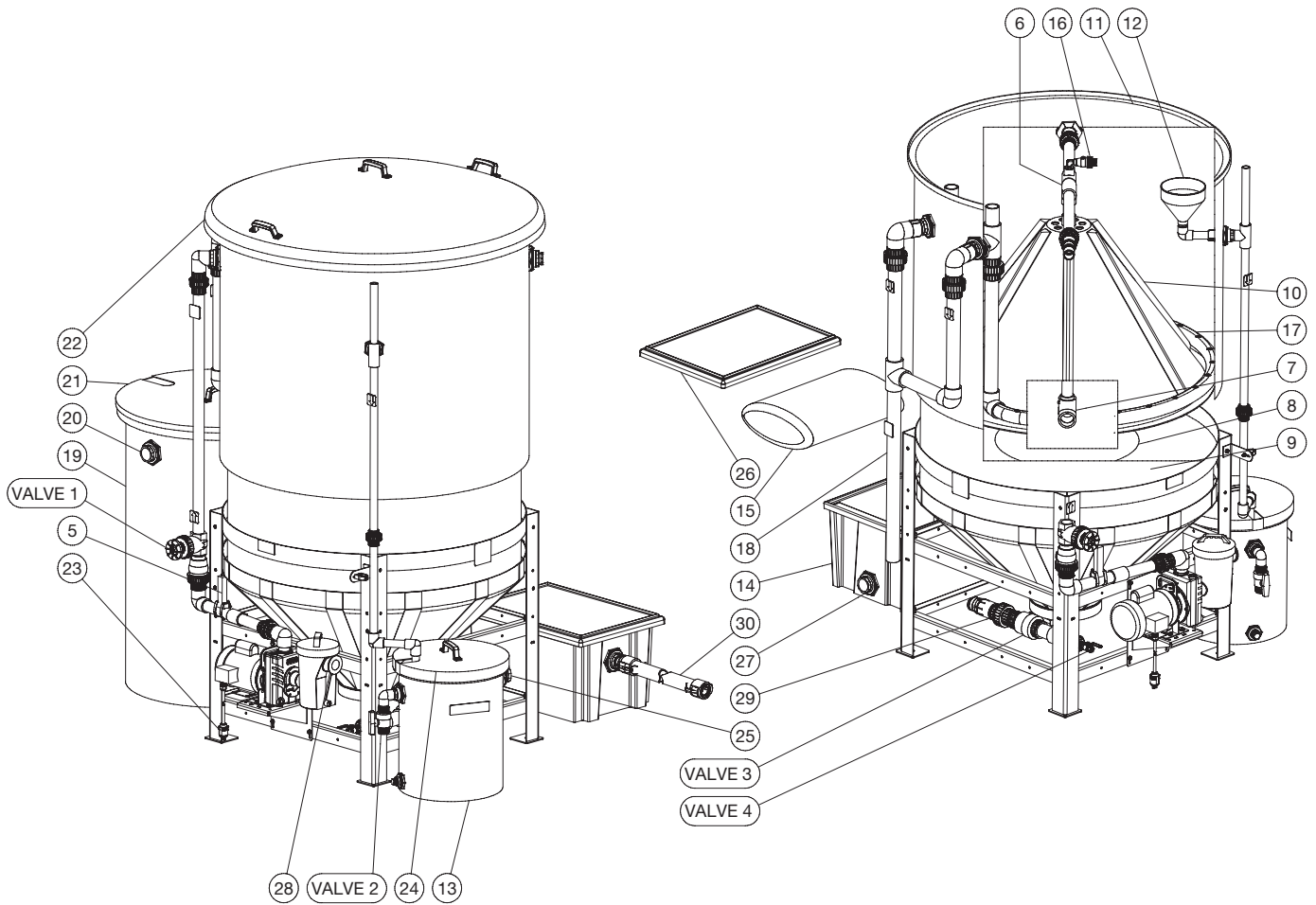

WCL-10S_30S-0M10 FEATURES 092721

-Water Inlet Flow Control **Valve 1**

-Waste Oil Release **Valve 2**

-Solids Drain **Valve 3**

-Clean Out **Valve 4**

- | | |
|------------------------------|------------------------------------|
| 5. Flow Meter | 18. Outlet Tee |
| 6. Inlet Tee | 19. Product Tank (optional) |
| 7. Diverter Tee | 20. Product Tank Outlet (optional) |
| 8. Solids Deflection Cone | 21. Product Tank Lid (optional) |
| 9. Solids Separation Chamber | 22. Clarifier Tank Lid |
| 10. Top Separation Cone | 23. Plug-In |
| 11. Oil Separation Chamber | 24. Oil Decanter Lid |
| 12. Oil Skimmer | 25. Oil Decanter Outlet |
| 13. Waste Oil Decanter | 26. Sludge Tub Lid |
| 14. Sludge Tub | 27. Sludge Tub Outlet |
| 15. Filter Bag | 28. Inlet |
| 16. Anti-siphon Device | 29. Sludge Outlet Assembly |
| 17. Outlet Ring | 30. Sludge Hose |

INSTALLATION

ASSEMBLY OF WCL-10/30S-0M10:

First unpack all components and check for damage. Contact the freight line if a damage claim is required on any component. The new style WCL-10S and 30S will come with sump pump mounted and most of the plumbing installed. Ensure all union connections with unit are tight.

ATTIRE:

1. Proper attire is essential to your safety. It is advised to utilize whatever means necessary to protect eyes, ears, and skin.

INSTALLATION:

1. A Collection Pit System must already be an established structure before installing the Clarifier Type Solids Separator. A well designed pit system is critical for the proper operation of the treatment system. Consult your Mi-T-M dealer for installation requirements.
2. Place the Clarifier Type Solids Separator on a hard, level surface in an area free of flammable vapors, combustible dust, gases or other combustible materials. Set the unit so you have access to the Water Inlet Flow Control Valve 1 and the Solids Drain Valve 3. Place a level on the Clarifier Type Solids Separator to ensure it is level.
3. Do not place unit in an area:
 - with insufficient ventilation.
 - where environmental hazards (i.e. rain and snow) can come in contact with the oil water separator system.
 - in a freezing environment.
4. The oil water separator system may be shipped with union connections loosened to protect the unit from shipping damage. Tighten all union connections at this time.
5. The unit comes with the sump pump mounted to the tank stand. Use the following guidelines before plumbing in the sump pump. (Also see diagram on next page).
 - Install the unit with the sump pump as near the pit as possible. The sump pump has a maximum suction head of 25 ft. This includes the vertical lift plus the friction losses on the inlet of the pump. Consult factory with questions.
 - If the suction head is over the maximum, uninstall the sump pump from unit and install as close to the pit as reasonable still being sure to be below the maximum suction head allowed. Additional plumbing will be required to attach to the inlet plumbing of the clarifier.
 - Keep in mind also, the shorter the suction piping is, the quicker the pump will be able to prime.
6. Use schedule 80 PVC connections. At least 2" suction plumbing is recommended.
 - a. Install a check valve and/or foot valve in the suction piping.
 - b. Keep piping high enough off the bottom of the pit to avoid the solids that will collect.
 - c. Install float w/ plug 10" above the inlet of the suction pipe. The 230V plug will be plugged into a 230V outlet. Allow a 2" tether and enough room to freely move without interfering with plumbing.

NOTE: *The above information is for reference only. Professional installers or architects may use this guideline to meet specific site requirements.*

7. Connect the **Sludge Hose (30)** to the **Sludge Outlet Assembly (29)** and the **Sludge Tub (14)**.
8. Install the return plumbing from the **Oil Decanter Outlet (25)** and the **Sludge Tub Outlet (27)** to the **Wash Water Catch Pit (1)** using 1-1/2" minimum connection sizes.
9. Install plumbing from **Outlet Tee (18)** or **product tank (optional) (19)** to a secondary treatment system for further processing or disposal. Do not send the water back to the **Sump Pit (3)**.
10. A pressurized water source may also be installed into the Clean Out Valve 4 to assist in purging the system of built of solids.

NOTE: *In most cases, you must have a permit to legally dispose discharged water.*

INSTALLATION

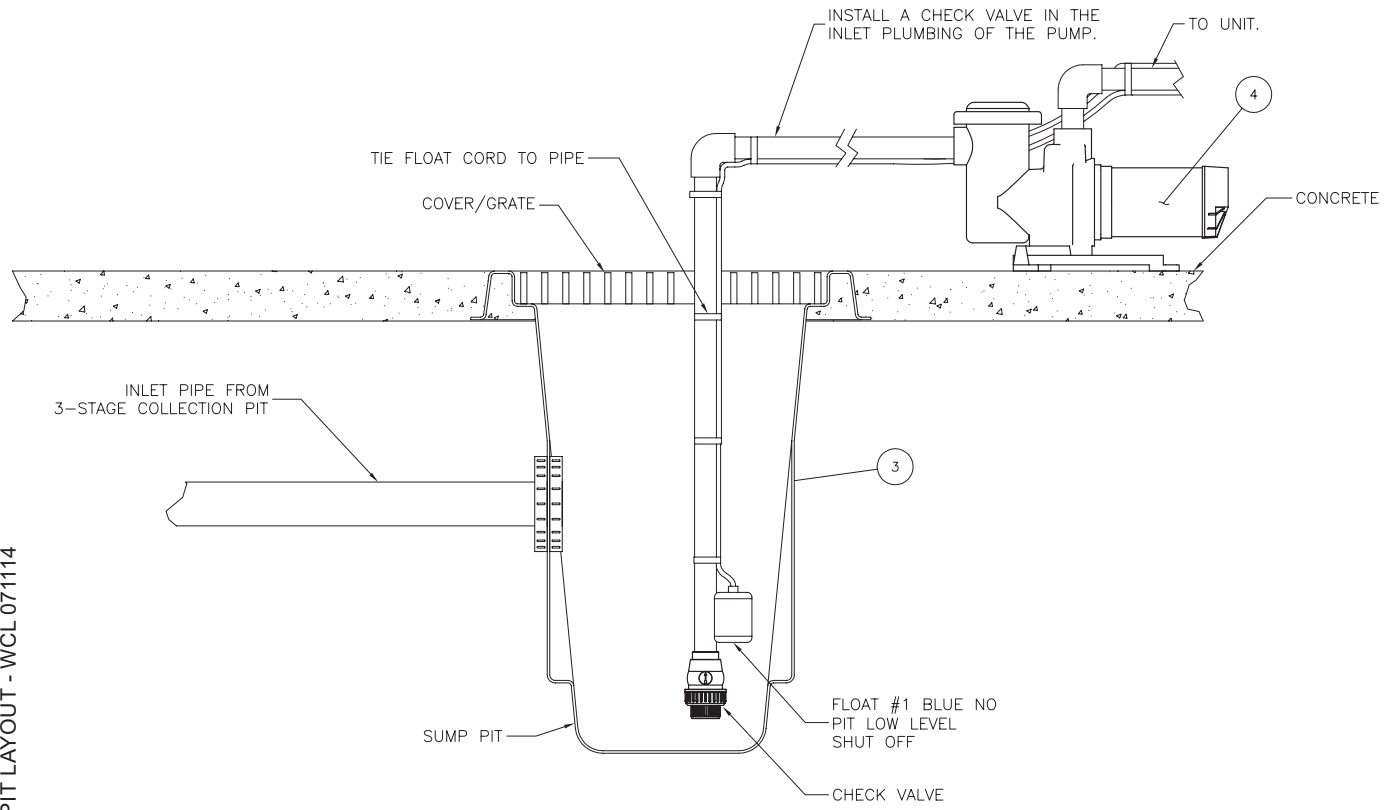

SUMP PIT LAYOUT - WCL 071114

PREPARATION

STOP

TO ENSURE YOUR WATER RECYCLE TREATMENT SYSTEM OPERATES SAFELY AND EFFICIENTLY, COMPLETE THE PRE-OPERATION CHECKLIST BEFORE PROCEEDING.

PRE-OPERATION CHECKLIST

Before proceeding, answer all the questions on this checklist.	YES	NO
CODES:		
1. Does the electrical wiring meet all codes?		
2. Does plumbing meet all codes?		
LOCATION:		
1. Is the unit located on a hard level surface free of flammable vapors, combustible dust, gases or other combustible materials?		
2. Is the unit located in a large ventilated area?		
ELECTRICAL:		
1. Is the unit properly grounded?		
2. Does the power supply, voltage and amperage match the data plate?		
PLUMBING:		
1. Is the plumbing sized correctly?		
2. Is the check valve installed near the Sump Pump (4) ?		
3. Are all unions tightened?		
GENERAL:		
1. Have all operators using this unit read and understood this entire manual?		
2. Has the unit been installed by qualified service people who followed the instructions listed in this manual?		

IF "NO" WAS MARKED TO ANY OF THESE QUESTIONS, CORRECT THE SITUATION BEFORE OPERATING.

PRE-START PROCEDURES:

1. Turn Water Inlet Flow Control Valve 1 one rotation short of completely closed.
2. Ensure the **Sump Pit (3)** is filled with water.
3. Be certain all hoses and plumbing connections are secure.

WARNING

RISK OF ELECTROCUTION! TO REDUCE THE RISK OF ELECTROCUTION, KEEP ALL ELECTRICAL CONNECTIONS DRY AND OFF THE GROUND.

START-UP:

1. To prime the **Sump Pump (4)**, remove the lid over the basket strainer and fill the basket strainer and the plumbing from the **Sump Pit (3)** with water and replace the lid.
2. Turn on the **Sump Pump (4)** by plugging the sump pump plug into the piggyback plug of the float and into a grounded 230V outlet.
3. Flow can be increased by opening the Water Inlet Flow Control Valve 1 and reading the **Flow Meter (5)**.
4. As the water fills the **Solids Separation Chamber (9)**, it will begin to flow through the **Top Separator Cone (10)** and fill the **Oil Separation Chamber (11)**.
5. When the **Oil Separation Chamber (11)** is full, the water will begin to flow through the **Outlet Ring (17)** and into the **Outlet Tee (18)**.
6. The **Outlet Tee (18)** directs the water into the optional **Product Tank (19)** where it is ready for further processing.

OPERATION

1. The Clarifier Type Solids Separator is ready to operate.
2. With the sump pump running, set Water Inlet Flow Control Valve 1 so that the **Flow Meter (5)** reads the rated flow rate of the system.
3. **Oil Skimmer (12)** positioning must be done when water is flowing into the Clarifier Type Solids Separator at the rated flow rate.
 - a. Ensure the **Waste Oil Decanter (13)** is connected to the pit return line.
 - b. Tilt the **Oil Skimmer (12)** so that it just breaks the surface of the water.
4. Monitor the system closely the first few days to ensure smooth operation.

MAINTENANCE

WASTE OIL DECANTER:

1. The **Oil Skimmer (12)** removes the top layer of oil and water from **Oil Separation Chamber (11)** and sends it to the **Waste Oil Decanter (13)**.
2. As the **Waste Oil Decanter (13)** fills with the oil/water mixture, the oil will float to the top while the water remains on the bottom.
3. The water then moves up the standpipe, through the **Oil Decanter Outlet (25)**, and back to the **Wash Water Catch Pit (1)** to be recycled again.
4. As oil accumulates, it will have to periodically be removed from the **Waste Oil Decanter (13)**.
 - a. Place a 5 gallon bucket below Waste Oil Release Valve 2.
 - b. Open the Waste Oil Release Valve 2 and allow oil to flow into the 5 gallon bucket. Turn off the valve when water begins flowing into the bucket.
 - c. Dispose of oil according to EPA Standards.

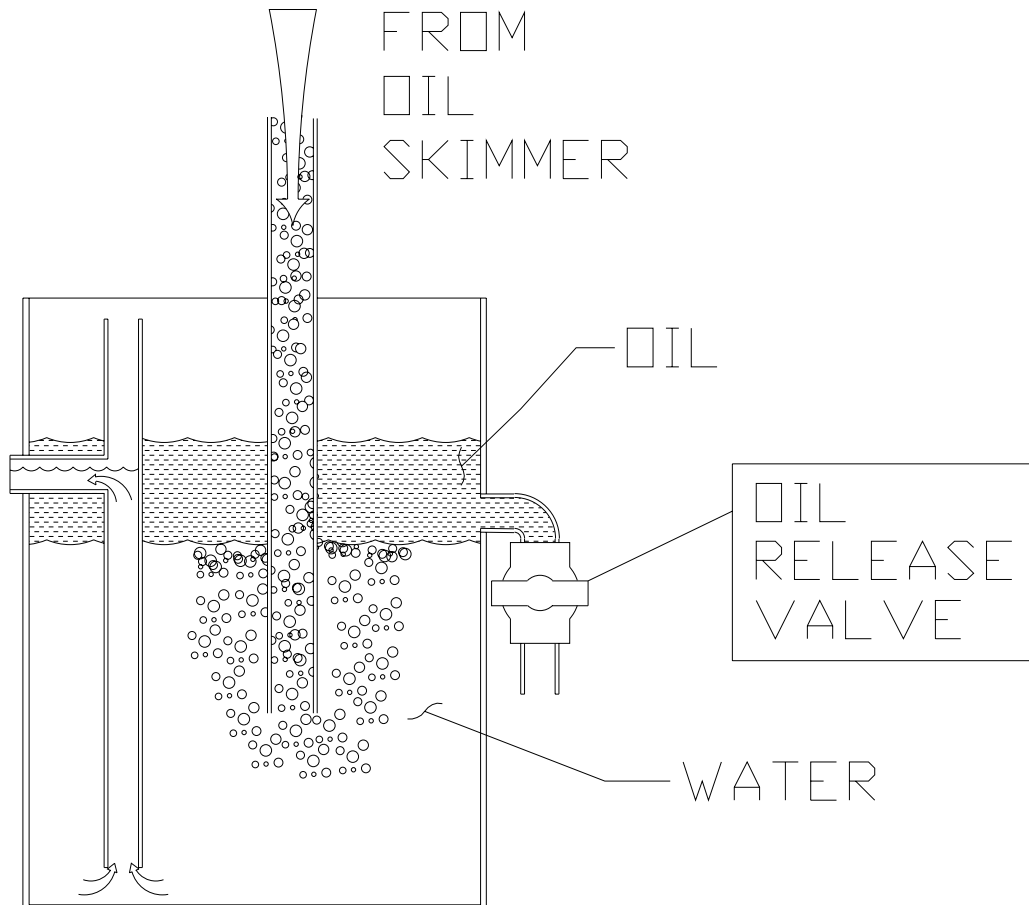

WCL-0026-030100-JJ

MAINTENANCE

SLUDGE TUB OPERATION:

The solids collection area of the **Solids Separation Chamber (9)** will need to be cleaned occasionally to prevent overflow of solids into the **Product Tank (optional) (19)**. Do not use pressure washers while performing this maintenance.

1. Ensure the **Sludge Hose (30)** is connected to the **Sludge Tub (14)** and the **Sludge Outlet Assembly (29)** and a **Filter Bag (15)** is secured in the **Sludge Tub (14)**.
2. By opening *Solids Drain Valve 3*, sludge from the **Solids Separation Chamber (9)** will enter the **Sludge Tub (14)**.
3. If there is no flow from the **Sludge Outlet Assembly (29)**, open *Clean Out Valve 4* and use a stiff wire to break up blockage.
4. The sludge is forced into the disposable **Filter Bag (15)**, Solids in the **Sludge** are retained by the disposable **Filter Bag (15)** and fluids drain out into the area created by the **Riser Plate**.
5. The remaining water drains out of the bottom of the **Sludge Tub (14)** through **Sludge Tub Outlet (27)** and back to the **Wash Water Catch Pit (1)**.
6. When the **Filter Bag (15)** is filled with accumulated solids, close the *Solids Drain Valve 3* and loosen the **Hose Clamp** used to retain the **Filter Bag (15)**. Tie the **Filter Bag (15)** off and dispose of in a manner consistent with local and federal regulations.
7. To replace the **Filter Bag (15)**, bunch up the neck and feed it through the **Hose Clamp**, place the **Hose Clamp** and **Filter Bag (15)** over the inside nipple on the inlet coupling and tighten the **Hose Clamp**.

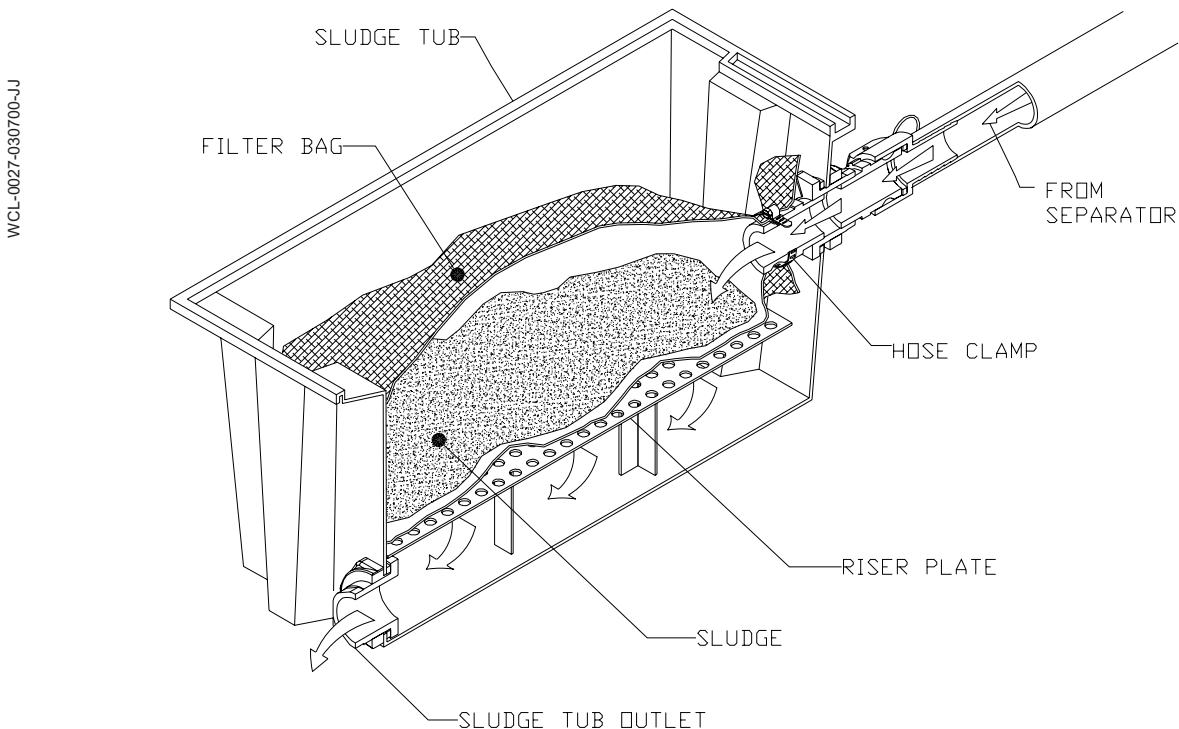

WINTERIZING:

If you must store your unit in an area where the temperature may fall below 32°F/0°C, you can protect your Clarifier Type Solids Separator system by draining all water from the system.

1. Unplug the unit.
2. Open the check valve near the **Sump Pit (3)** and drain the water transport line. Remove the **Sump Pump (4)** from the **Sump Pit (3)**.
3. Ensure all oil has been skimmed from the surface of the **Oil Separation Chamber (11)** by the **Oil Skimmer (12)**.
4. Remove the sludge from the bottom of the **Solids Separation Chamber (9)** as described in **SLUDGE TUB OPERATION**.
5. Open *Solids Drain Valve 3* and drain the Clarifier Type Solids Separator and clean the tank.
6. Remove the oil from the **Waste Oil Decanter (12)** and drain.
7. Empty the **Product Tank (19)** and wipe down the **Sludge Tub (14)**.

TROUBLESHOOTING

SYMPTOM	PROBABLE CAUSE	REMEDY
SUMP PUMP		
Sump Pump (4) will not run.	Floats are not adjusted correctly in the Sump Pit (3) .	Readjust.
	Not enough water in the Sump Pit (3) .	Add water to the Sump Pit (3) .
	Float 1 is defective.	Replace.
	Circuit overload/breaker has tripped.	Reset breaker or replace fuse at power source.
	Motor overload.	Allow motor to cool. Motor will automatically restart when cool.
	Motor is defective.	Replace motor.
Sump Pump (4) motor starts and stops frequently.	This is a common occurrence on initial start-up while pits are filling.	Allow pits to fill.
	Excessive water flow to water treatment system.	Turn valve clockwise to reduce flow.
	Sump Pump (4) impeller is clogged.	Disconnect power and unclog impeller.
	Motor overload.	Allow motor to cool. Motor will automatically restart when cool.
	Sump Pit (3) is not large enough.	Expand size of pit.
Sump Pump (4) runs, but there is little or no water discharge.	Strainer basket in Sump Pump (4) is clogged.	Clean, repair or replace.
	Water level is below pump inlet.	Ensure Float 1 is not caught in plumbing.
	There is an air lock in the Sump Pump (4) .	Manually fill the inlet pipe with water. Turn the Sump Pump (4) on and off several times.
	Low voltage.	Ensure wire size is capable of handling the rated amperage of the unit. If wire size is correct, contact your distributor.
	Clogged impeller or worn pump parts.	Contact your distributor.
Sump Pump (4) will not turn off.	Defective switch inside the Float (1).	Replace.
	Pump is air locked.	Cycle pump in one minute increments several times to clear air from pump. If system includes a check valve, a 3/16" hole should be drilled in the discharge pipe approximately 2" above the discharge connections.

TROUBLESHOOTING

SYMPTOM	PROBABLE CAUSE	REMEDY
---------	----------------	--------

SEPARATOR TANK

Water will not flow into the Separator	Sump Pump (4) is not plugged in.	Plug in Sump Pump (4) .
	Circuit breaker has tripped or is "OFF".	Reset or turn breaker "ON".
	Dirt is lodged in the pit check valve.	Clean.
	Sump Pump (4) impeller is clogged.	Disconnect power and clean.
	Lines or valves contain frozen water.	Allow to thaw. Inject with warm water if necessary.

SHAFT SEALS

Water is leaking at pumps.	Damaged stationary shaft seal.	Seal ran dry. Ensure seal chamber is filled with liquid.
Short seal life.	Unexpected temperature and chemical usage.	Replace.



STATEMENT OF WARRANTY

Mi-T-M warrants all parts (except those referred to below) of your new Clarifier type solids separator to be free from defects in materials and workmanship for one year from the date of original purchase.

Defective parts not subject to normal wear and tear will be repaired or replaced at Mi-T-M's option during the warranty period. In any event, reimbursement is limited to the purchase price paid.

EXCLUSIONS

1. The motor is covered under separate warranty by its respective manufacturer and is subject to the terms set forth therein.
2. Normal wear parts:

Seals	Gaskets
O-rings	Packings
Valve Assembly	Brushes
3. Parts damaged due to:
 - normal wear, misapplication, modifications/alterations, abuse,
 - operation at other than recommended speeds, pressures or temperature,
 - the use of caustic liquids,
 - chloride corrosion or chemical deterioration,
 - fluctuations in electrical or water supply,
 - operating unit in an abrasive, corrosive or freezing environment.
4. Parts damaged by failure to follow recommended:
 - installation, operating and maintenance procedures.
5. This warranty does not cover the cost of:
 - normal maintenance or adjustments,
 - labor charges,
 - transportation charges to Service Center,
 - freight damage.
6. The use of other than genuine Mi-T-M parts will void warranty.

Parts returned, prepaid to Mi-T-M's factory or to an Authorized Service Center will be inspected and replaced free of charge if found to be defective and subject to warranty. There are no warranties which extend beyond the description of the face hereof. Under no circumstances shall Mi-T-M bear any responsibility for loss of use of the unit, loss of time or rental, inconvenience, commercial loss or consequential damages.

Manufactured by Mi-T-M
50 Mi-T-M Drive, Peosta IA 52068
563-556-7484/ Fax 563-556-1235