



## INSTALLATION MANUAL FOR Mi-T-M® ***IN-GROUND FIBERGLASS PIT SYSTEMS***

Sump Pit

3-Stage Collection Pit

Catch Basin Pit

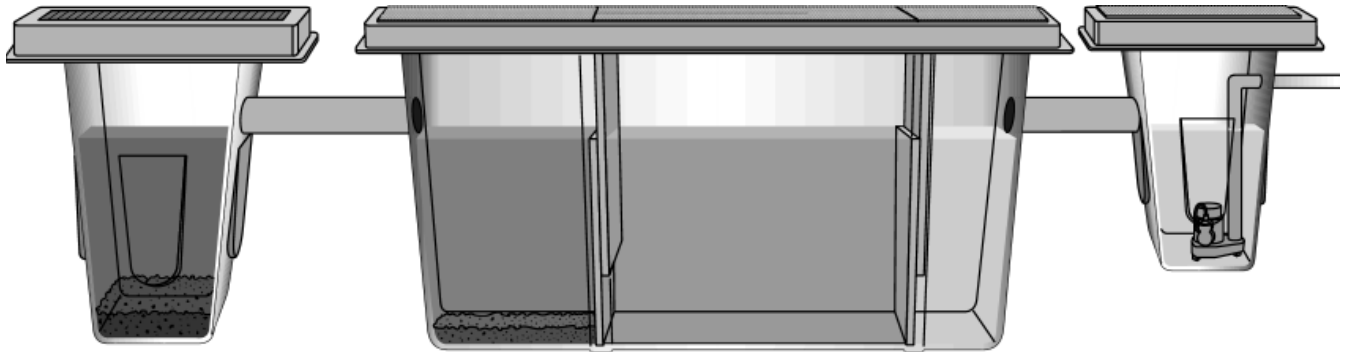

### **Utilization of Brace Kits are Recommended (Not Included)**

2 x 2 Sump Pit Internal Brace Kit #:	RC-0001-0001
3 x 3 Catch Basin Pit Internal Brace Kit #:	RC-0001-0002
3 x 9 3-Stage Collection Pit Internal Brace Kit #:	RC-0001-0003

## TABLE OF CONTENTS

SPECIFICATIONS .....	2
INTRODUCTION .....	3
IMPORTANT SAFETY WARNINGS .....	4
FLOW CHART .....	4
INSTALLATION .....	5-14
ACCESSORIES .....	16
PARTS LIST .....	17-18
STATEMENT OF WARRANTY .....	19

## SPECIFICATIONS

PART #	12-0071	12-0074	12-0073
DESCRIPTION	3 x 3 Catch Basin Pit	3 x 9 3-Stage Collection Pit	2 x 2 Sump Pit
PIT CONSTRUCTION	Fiberglass	Fiberglass	Fiberglass
CAPACITY (Gallons)	160	600	50
DIMENSIONS L x W x H	46 x 46 x 57	118 x 46 x 57	32 x 32 x 39
NET WEIGHT (lbs.)	68	240	35

### ⚠ WARNING

⚠ WARNING: This product can expose you to chemicals including Lead, which is known to the State of California to cause cancer and birth defects or other reproductive harm. For more information go to [www.P65Warnings.ca.gov](http://www.P65Warnings.ca.gov)

### ⚠ WARNING

⚠ WARNING: This product can expose you to chemicals including carbon monoxide, which is known to the State of California to cause birth defects or other reproductive harm. For more information go to [www.P65Warnings.ca.gov](http://www.P65Warnings.ca.gov)

## INTRODUCTION

Congratulations on the purchase of your new Mi-T-M Fiberglass Pit System! Mi-T-M offers premium quality fiberglass pit components boasting features created with the customer in mind to exceed the performance of any concrete pit system.

### ***Economical***

*-Considerably less expensive.  
-Accepts universal coalescing grids  
instead of custom made baffles.*

### ***Lightweight***

*-Significantly easier installation.  
-Minimal shipping fees.*

### ***High Performance Construction***

*-Conforms to Current Government Regulations.  
-Earthquake resistant.  
-Chemical & pH resistant.  
-Double wall construction design.*

### ***Versatile***

*-Designed for a variety of usages.*

Mi-T-M helps you create the appropriate pre-treatment pit system for your Wash-Water Recycle or Sewer Discharge operations. The various pit components are designed to conform to the unique requirements of each customer's individual water treatment design. Mi-T-M Fiberglass Pit Systems are designed for sublevel applications that offer a wide variety of usages including:

*Rental Yards  
Heavy Equipment Dealers  
Trucking Facilities  
Golf Courses  
Military Bases  
Truck Rental Fleets  
Forklift Washing Operations  
Aircraft Maintenance & Restoration  
Shipyards  
Diesel Repair Facilities  
Engine Rebuilders & Manufacturers  
Oil Fields*

This installation manual was compiled for your benefit. By reading and following the simple safety and installation steps described in this manual, you will receive years of trouble free operation from your new Mi-T-M Fiberglass Pit System. The contents of this manual are based on the latest product information available at the time of publication. Mi-T-M reserves the right to make changes in price, color, materials, equipment, specifications or models at any time without notice.

**ALWAYS PROVIDE A COPY OF THIS MANUAL TO ANYONE USING THIS EQUIPMENT. READ ALL INSTRUCTIONS BEFORE INSTALLING THIS FIBERGLASS PIT SYSTEM AND ESPECIALLY POINT OUT THE "SAFETY WARNINGS" TO PREVENT THE POSSIBILITY OF PERSONAL INJURY TO THE OPERATOR.**

Inspect for signs of obvious or concealed freight damage. If damage does exist, file a claim with the transportation company immediately. Be sure that all damaged parts are replaced and that the mechanical and electrical problems are corrected prior to operation of the unit. If you require service, contact Mi-T-M Customer Service.

CALL OUR TOLL-FREE NUMBER

800-553-9053

for the Sales or Service Center nearest you!

Please have the following information available for all service calls:

1. Part Number
2. Date and Place of Purchase



# IMPORTANT SAFETY WARNINGS

READ ALL SAFETY WARNINGS BEFORE INSTALLING IN-GROUND FIBERGLASS PIT SYSTEM



HAZARD	POTENTIAL CONSEQUENCE	PREVENTION
<p><b>RISK OF BODILY INJURY</b></p> 	<p>Injury may occur from the In-ground Fiberglass Pit System.</p>	<p>Do not install without reading and understanding the entire manual. Improper installation will void warranty.</p> <p>DO NOT overreach or stand on unstable support including pit bracing.</p> <p>Wet surfaces can be slippery, wear protective foot gear and keep good footing and balance at all times.</p> <p>DO NOT DRINK THE WATER IN THE IN-GROUND FIBERGLASS PIT SYSTEM!! This is non-potable water and is not suitable for consumption.</p> <p>Do not submerge yourself or pets into an operable pit.</p>

**!SAVE THESE INSTRUCTIONS!**

## FLOW CHART

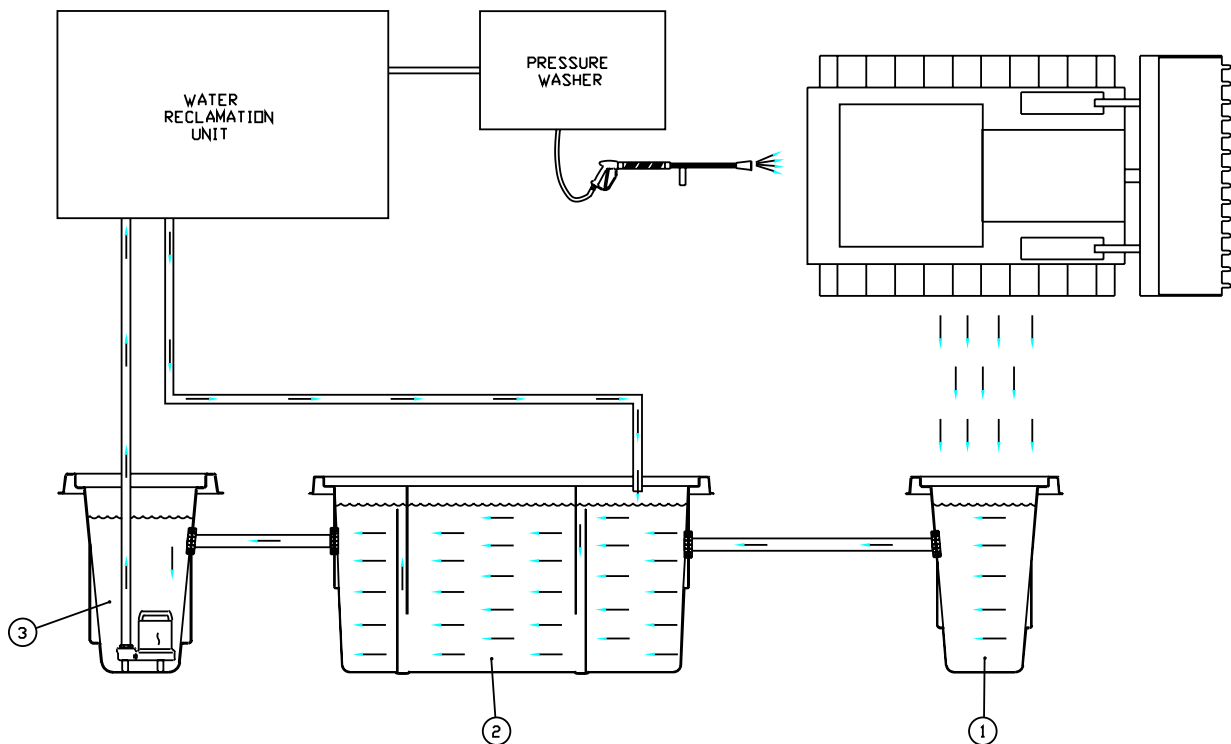

PITS009-060299-JTR

As pressure washers are being operated, used water flows into the **Wash Water Catch Pit (1)**. From there, it moves into the core of the system; the **3-Stage Collection Pit (2)**. The performance of this pit regulates the performance of your entire system. This pit is designed to remove initial contaminants from the system. Increasing the amount of contaminants removed at this stage, increases the life of the remaining components in your system. After moving through a series of cleansing weirs in the 3-Stage Collection pit, the water flows into the **Sump Pit (3)**. Water is then pumped into the Reclamation Unit for final cleansing before being sent back to the pressure washers.

# INSTALLATION

## 1. DESIGN

a pit system to fit your needs. Mi-T-M is available to help with your design. Layout the location and amount of pits needed for your unique operation. Mi-T-M pits are constructed with a variety of flats molded into the pit to allow multiple piping options in your design.

Shown below are examples of established pit systems.

PITS010-060299-JTR

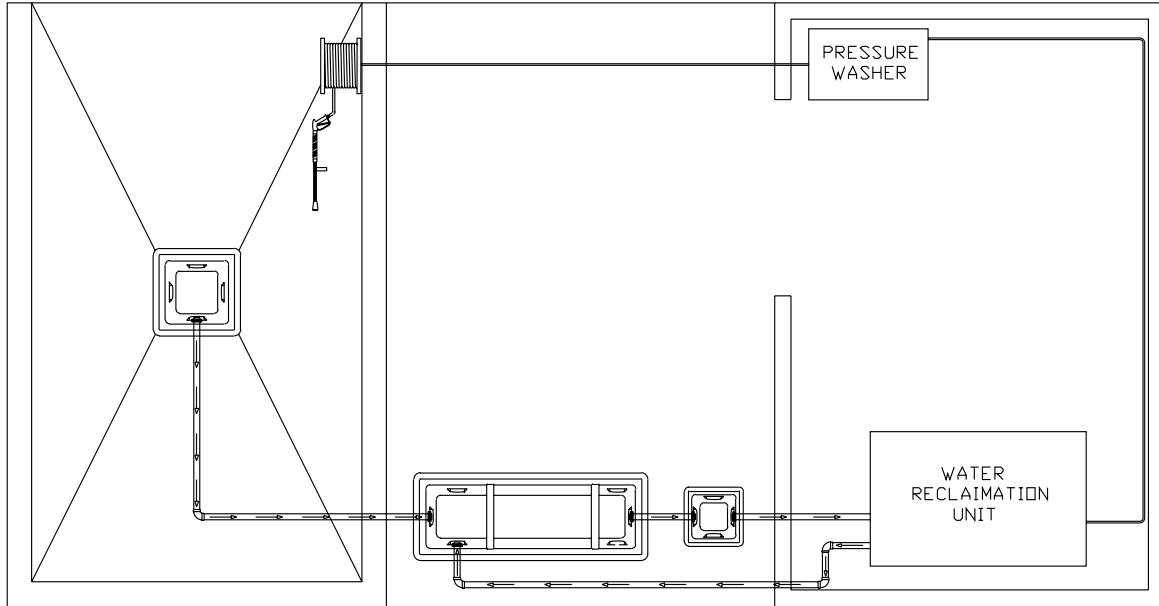

PITS010B-060299-JTR

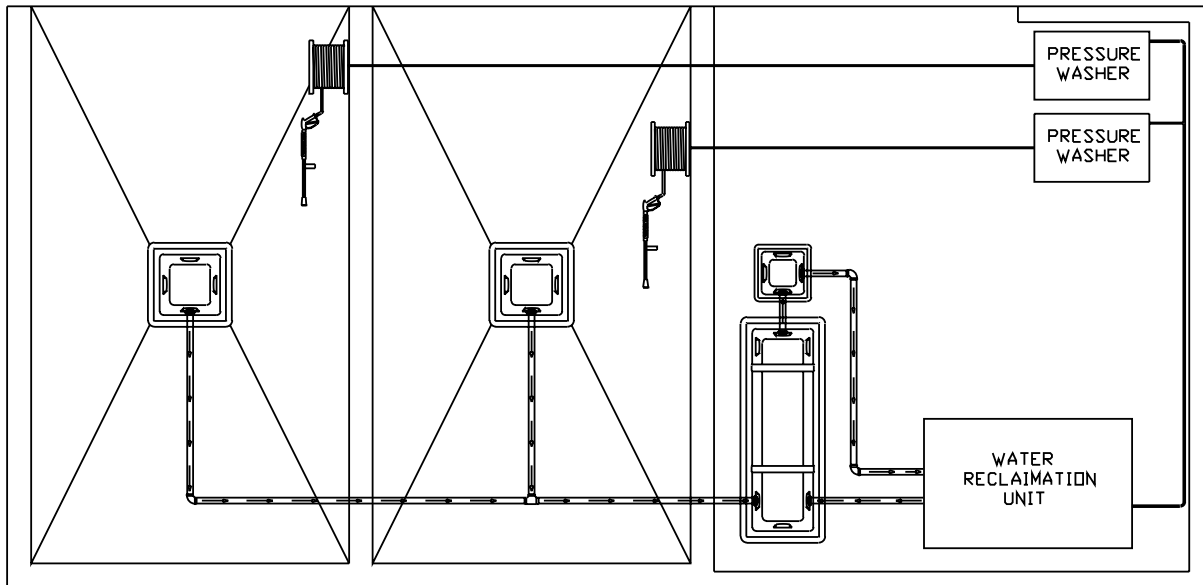

# INSTALLATION

## 2. EXCAVATE

an area which will allow a wall of concrete under and around all the sides of the pit which you are installing. The thickness of the concrete housing should be a minimum of 4" and a maximum of 8". The housing should be equal to the slab thickness at the pit surface unless the slab thickness exceeds 8". In this case, an 8" maximum concrete housing is sufficient. Angle the edges of the excavated area to allow the slab to solidly conform to the concrete housing.

2.1 If you are installing the pits in an area where you must cut through an existing concrete bed before excavating, use the dimensions shown below. All other instructions in this manual will apply to your installation.

PIT-0003-061799-JTR

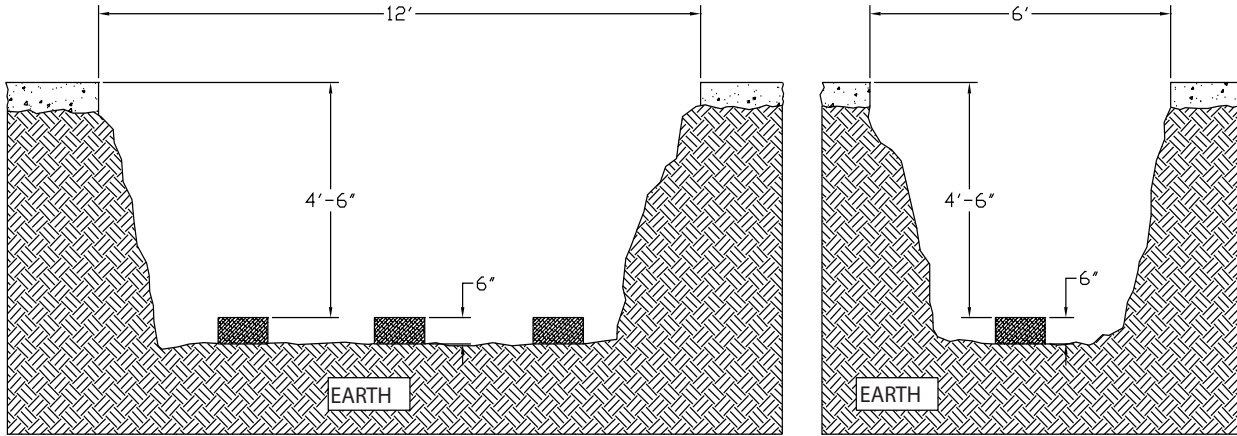

## 3x9 PIT

PIT-0008-061799-JTR

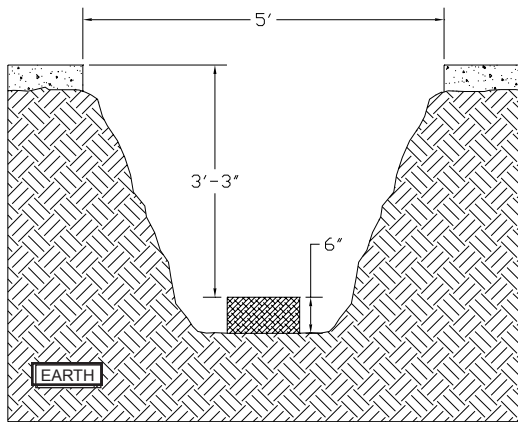

## 2X2 PIT

PIT-0006-061799-JTR

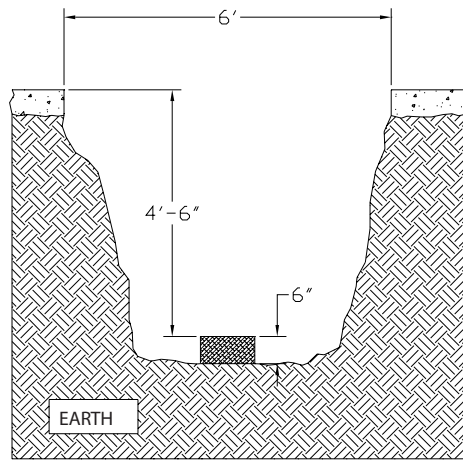

## 3x3 PIT

# INSTALLATION

2.2 If you are excavating new pits, use the dimensions shown below. All other instructions in this manual will apply to your installation.

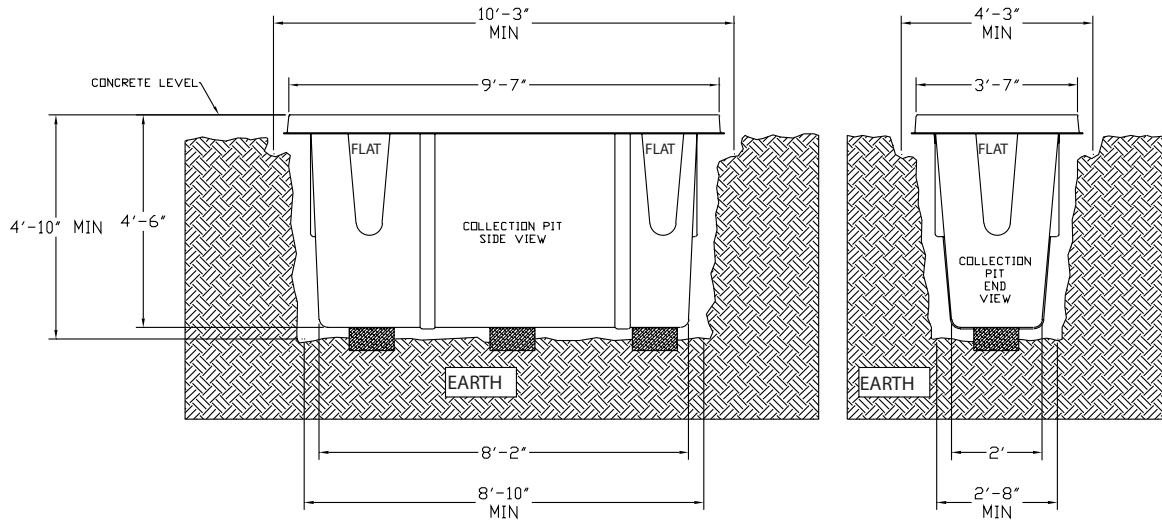

PIT-0001-061799-JTR

## 3x9 PIT

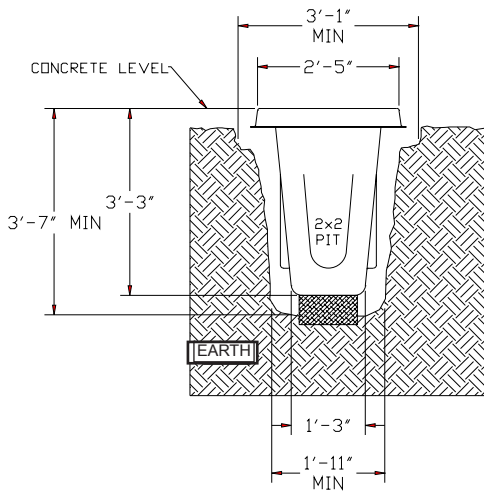

PIT-0007-061799-JTR

## 2X2 PIT

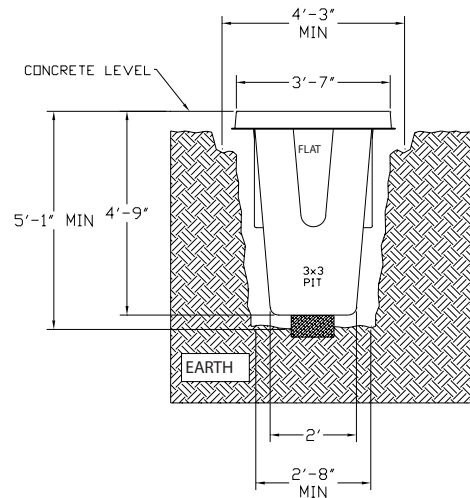

PIT-0004-061799-JTR

## 3X3 PIT

### 3. LEVEL

the floor of the excavation and set concrete blocks in the areas where the Pit(s) will be placed. The 3-Stage Collection Pit requires three concrete blocks while the remaining pits need only one. Place a level across the concrete blocks to ensure they create an even plane for the Pit(s) to rest upon.

### 4. PLACE

the Pit(s) on top of the concrete block(s) in their designated area(s). Keep in mind each Pit is molded with flats in several locations to conform to the unique requirements of each customer's individual design. Position the pit to ensure a plumbing connection lines up with a flat. It is *not* recommended to cut plumbing connection holes in the flat at this time because the pits are too unstable. The hole cutting step of the installation is best completed after the initial concrete pour. Once the pit is stabilized in concrete, the stress on the plumbing connections is significantly reduced, helping prevent future leaks.

# INSTALLATION

## 5. BRACE

the Pit(s). Brace kits are required for sublevel placement of pits to prevent movement while pouring the concrete housing. Bracing may be accessed in one of two ways:

- Order Brace Kits through your local distributor using the part numbers that correspond with your pit. These kits are reusable and therefore may also be utilized in future installations. Use the appropriate Brace Kit following the instructions provided for proper installation.
- Construct the desired Brace Kit using the dimensions shown in this manual.

### ORDER BRACE KIT #RC-0001-0001 FOR 2x2 PIT

PIT-00019-060299-JTR

PIT0019-060299-JTR

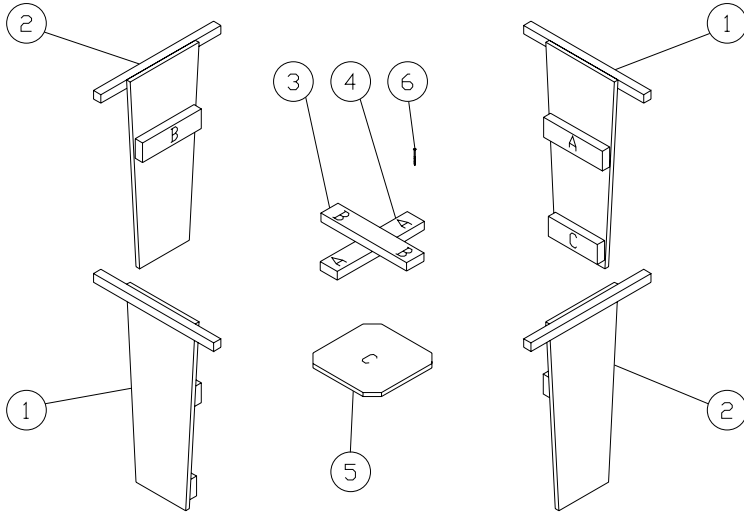

BRACE KIT #RC-0001-0001 FOR 2x2 SUMP PIT		
REF. #	DESCRIPTION	QTY.
1	Side Brace-2 Cross Bars	2
2	Side Brace-1 Cross Bar	2
3	Cross Brace "B"	1
4	Cross Brace "A"	1
5	Lower Brace	1
6	Wood Screw	7

### CONSTRUCT BRACE KIT FOR 2x2 PIT

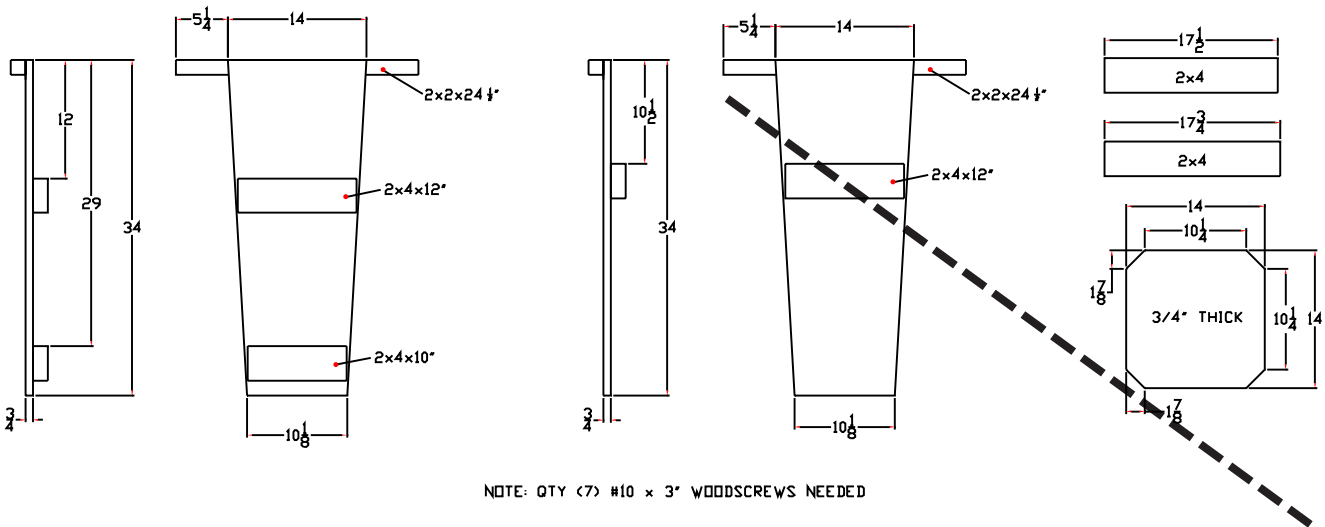

NOTE: QTY (7) #10 x 3" WOODSCREWS NEEDED

PIT-00019B-060299-JTR



# INSTALLATION

## ORDER BRACE KIT #RC-0001-0002 FOR 3x3 PIT

PIT0020-060299-JTR

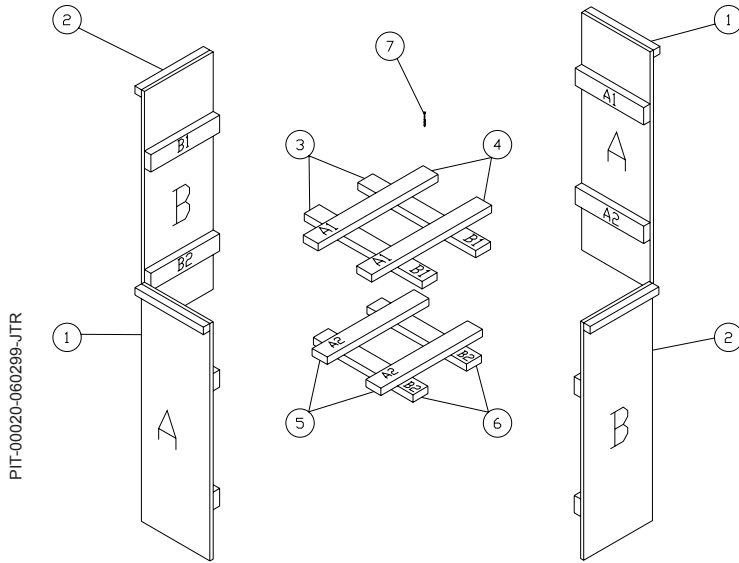

BRACE KIT #RC-0001-0002 FOR 3x3 CATCH BASIN		
REF. #	DESCRIPTION	QTY.
1	Side Brace "A"	2
2	Side Brace "B"	2
3	Cross Brace "B1"	2
4	Cross Brace "A1"	2
5	Cross Brace "A2"	2
6	Cross Brace "B2"	2
7	Wood Screw	16

### CONSTRUCT BRACING FOR 3x3 PIT

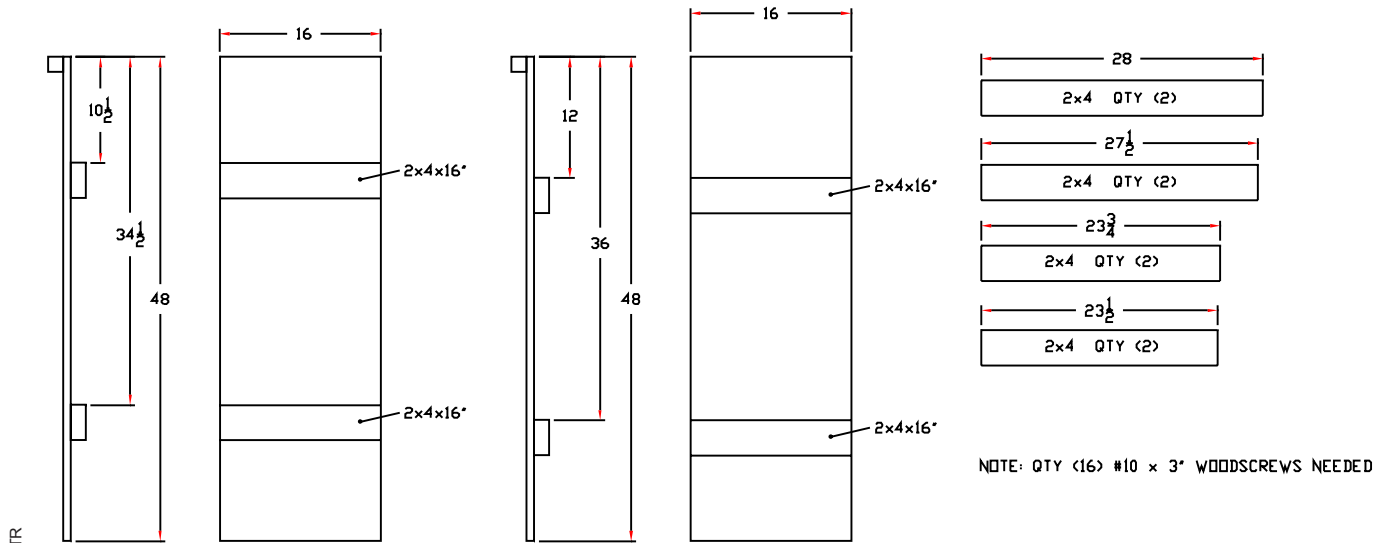

# INSTALLATION

## ORDER BRACE KIT #RC-0001-0003 for 3x9 3-Stage Collection Pit

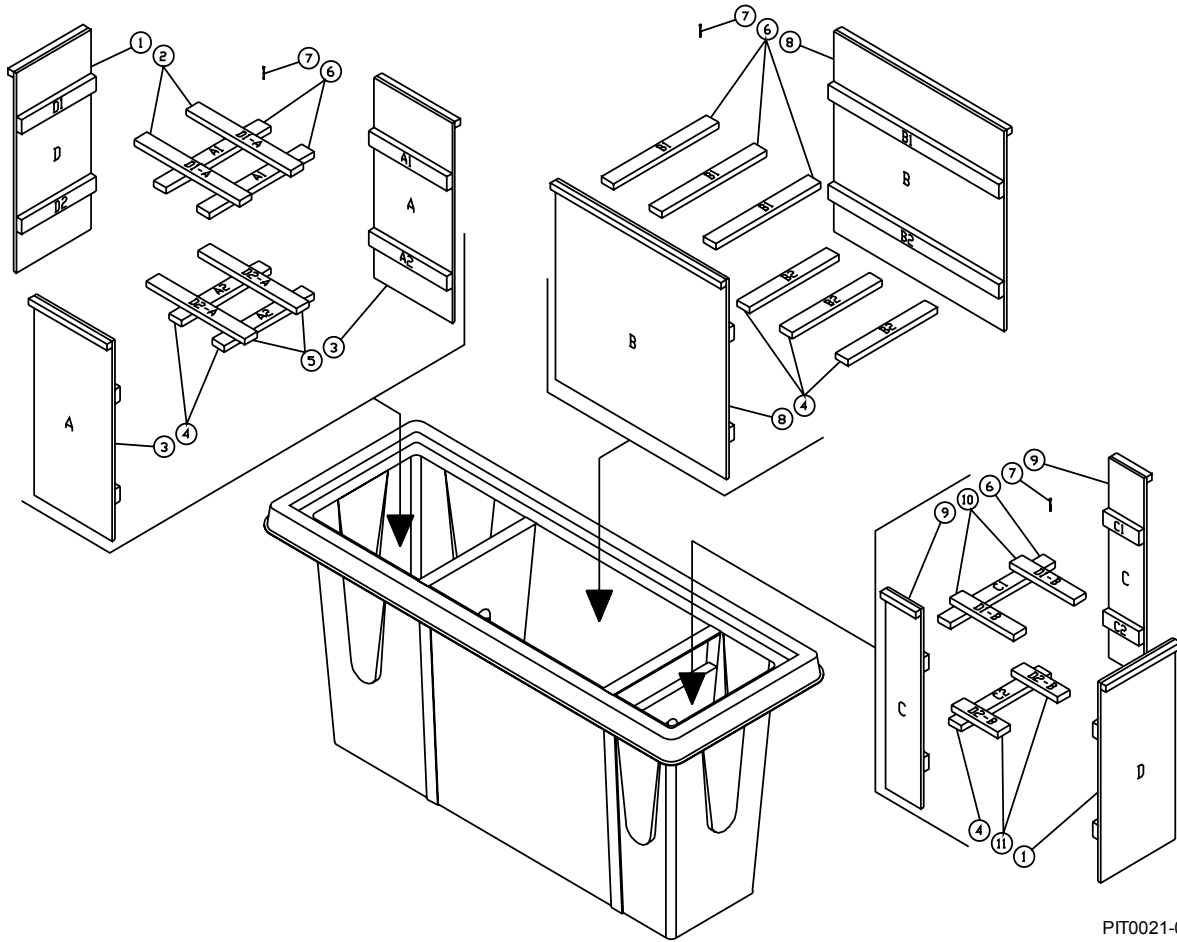

PIT-00021-060299-JTR

PIT0021-060299-JTR

BRACING-LARGE PIT		
REF. #	DESCRIPTION	QTY.
1	Side Brace "D"	2
2	Cross Brace "D1-A"	2
3	Side Brace "A"	2
4	Cross Brace "A2, B2, C2"	6
5	Cross Brace "D2"	2
6	Cross Brace "A1, B1, C1"	6
7	Wood Screw	44
8	Side Brace "B"	2
9	Side Brace "C"	2
10	Cross Brace "D1-B"	2
11	Cross Brace "D2-B"	2

# INSTALLATION

## CONSTRUCT BRACING

### FOR 3x9 3-STAGE COLLECTION PIT

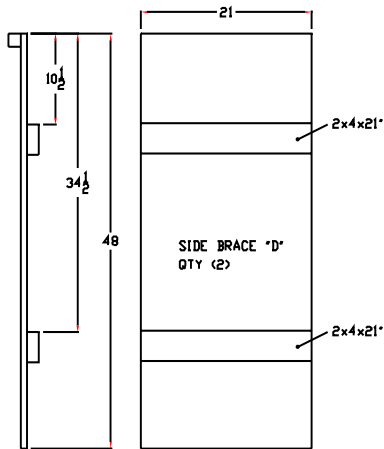
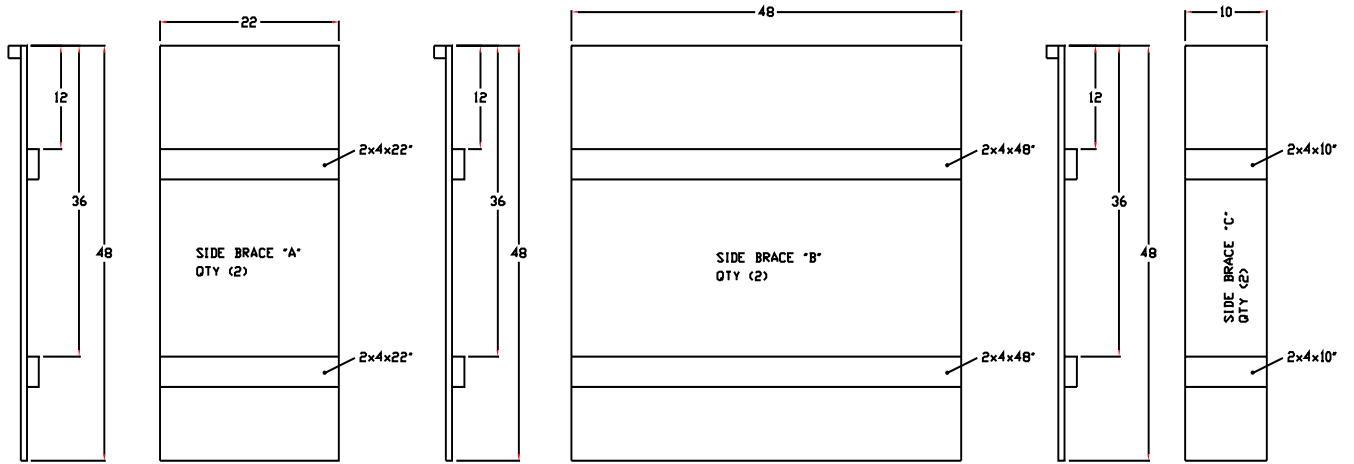

CROSS BRACES: A1, B1, AND C1

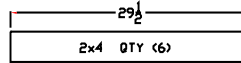

CROSS BRACES: D2-A

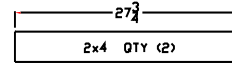

CROSS BRACES: A2, B2, AND C2

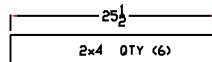

CROSS BRACES: D2-B

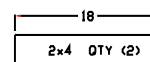

CROSS BRACES: D1-A

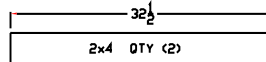

NOTE: QTY (44) #10 x 3" WOODSCREWS NEEDED

CROSS BRACES: D1-B

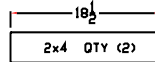

PIT-00021B-060299-JTR

## INSTALLATION

### 6. **STABILIZE**

the pits with angle irons (or the equivalent) to prevent the pits from rising while the concrete housing is being poured.

### 7. **POUR**

the 1st of 3 phases of concrete. This phase should cover the concrete blocks and approximately the first 1/3 of the pit. Allow the concrete to cure for 24 hours. *Do not pour concrete completely to the top of the pit. Doing so can create enough pressure to force the pits to rise, and possibly bend the angle iron supports.*

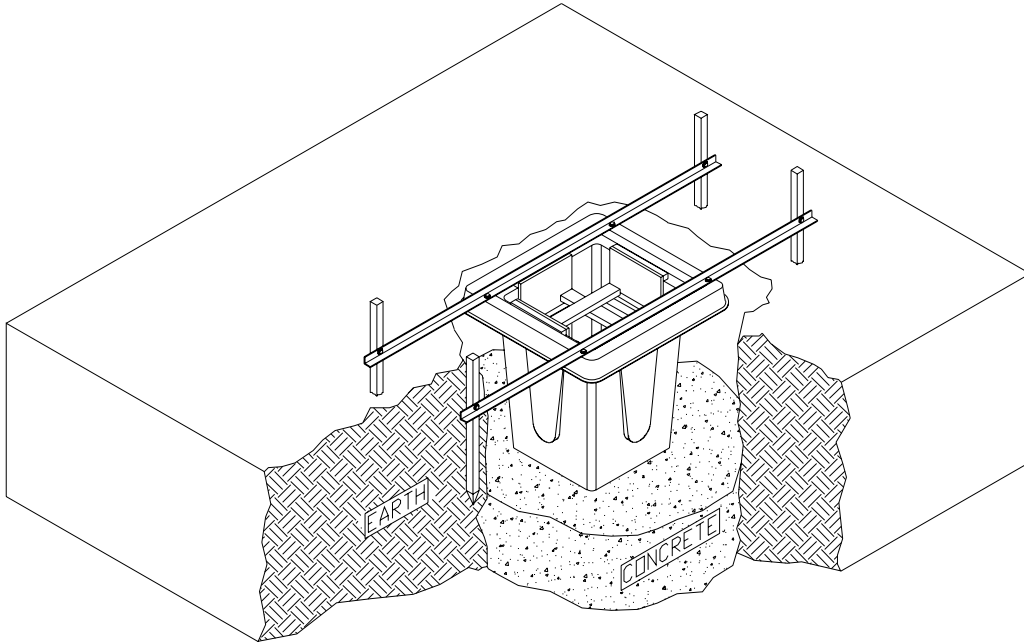

PIT-0005B-061599-JTR

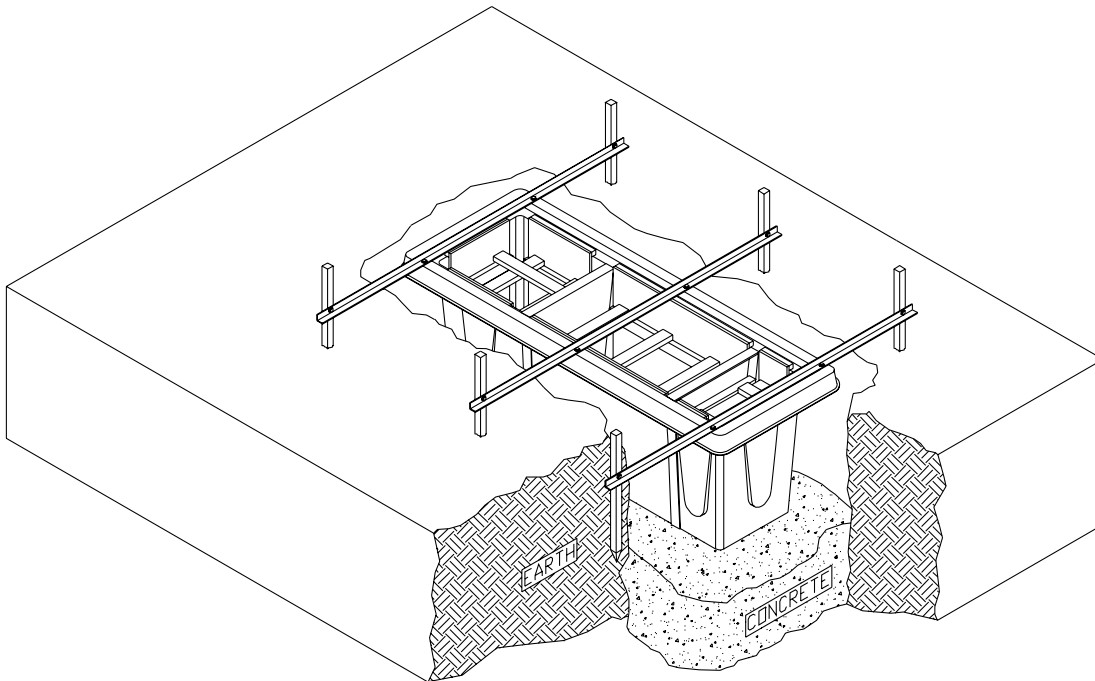

PIT-0002B-061599-JTR

# INSTALLATION

## 8. **EXCAVATE**

trenches and layout the required plumbing needed for your pit system. Be certain the plumbing alignment ensures the gravity feeds are maintained throughout the system.

## 9. **REMOVE**

the internal bracing of the pits and set aside. The internal bracing will be reinstalled after plumbing connection holes have been cut in the pits.

## 10. **CUT**

plumbing connection holes in the designated areas of the pit to conform to the inlet and outlet connections of your design.

Starting with the catch basin, drill a hole approximately 1/3 down from the top of the basin to the center point of the hole.

Allow a 2% grade in plumbing to each consecutive pit to ensure gravity feeds are maintained throughout the system.

## 11. **INSERT**

the bulkhead fittings into the plumbing connection holes and tighten securely. Attach the plumbing connections securely to the bulkhead fittings. When all plumbing is fastened, reinstall the internal bracing (and angle irons if previously removed).

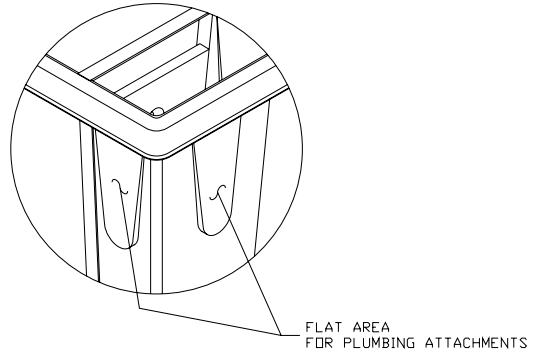

PIT-0013-061599-JTR

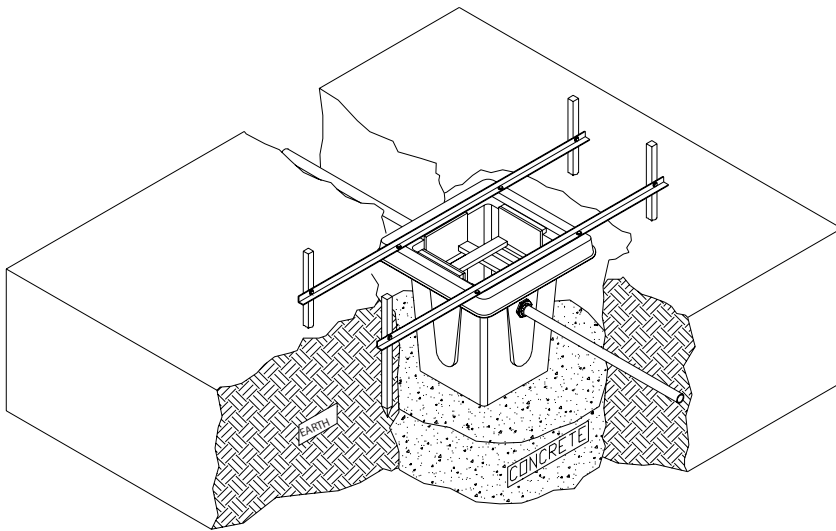

PIT-0005-061599-JTR

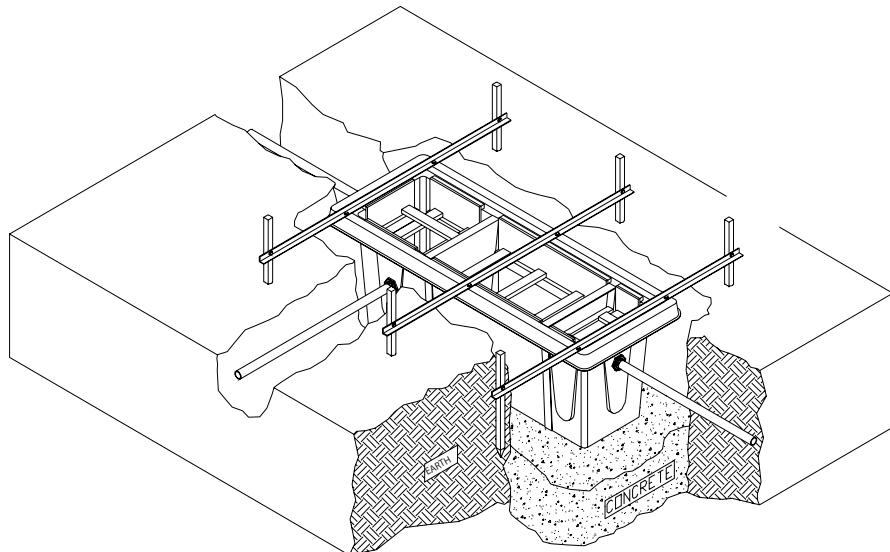

PIT-0002-061599-JTR

# INSTALLATION

**NOTE:** Inlet portion of pit is the larger of the two end compartments.

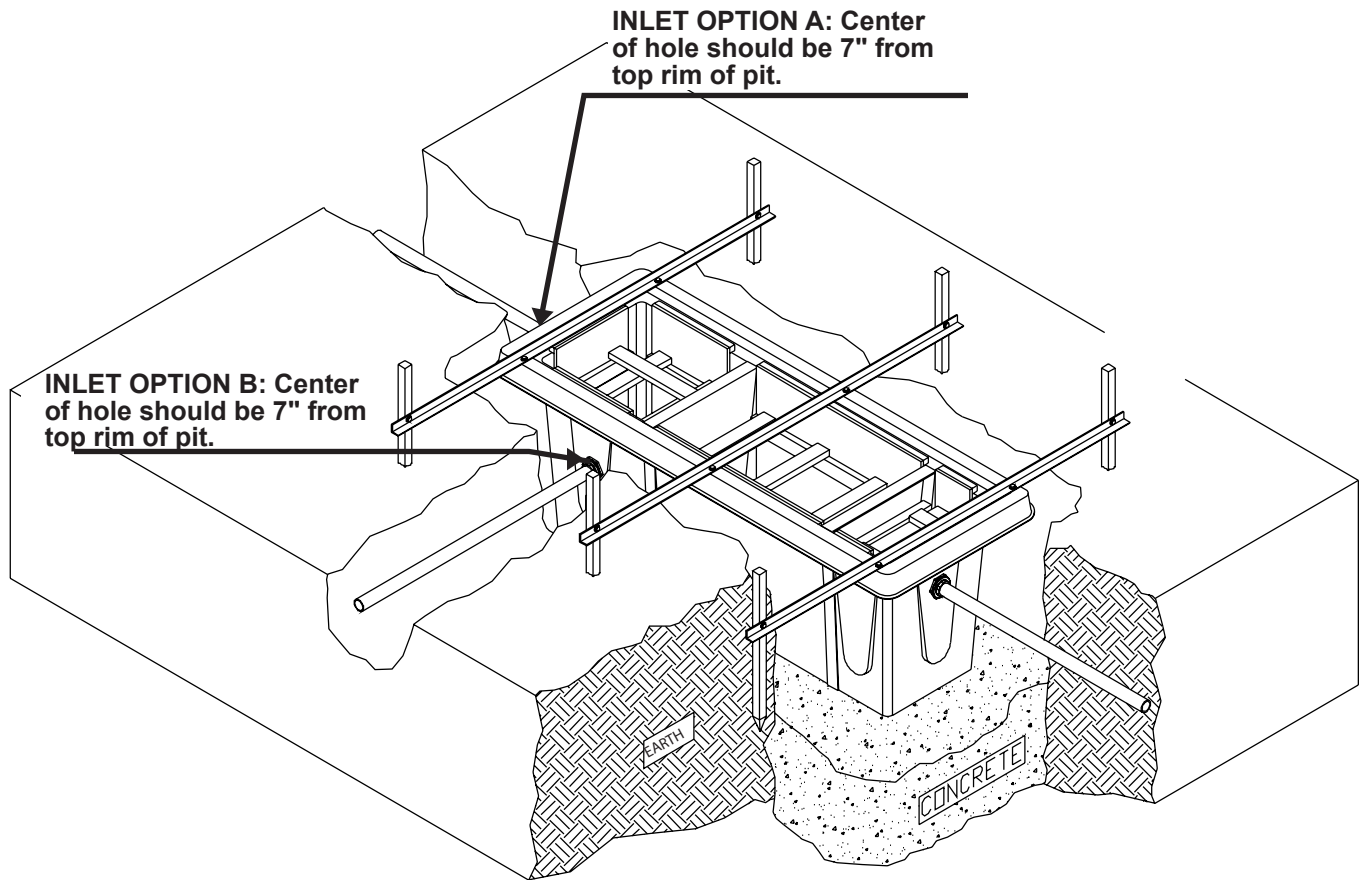

PIT-0002-061599-JTR

# INSTALLATION

## 12. **POUR**

the 2nd phase of concrete. This phase of concrete should be poured until the level is approximately 6" below the plumbing. Do not pour concrete completely to the top of the pit. Doing so can create enough pressure to force the pits to rise, and possibly bend the angle iron supports. Allow this phase of concrete to cure for approximately 2 days.

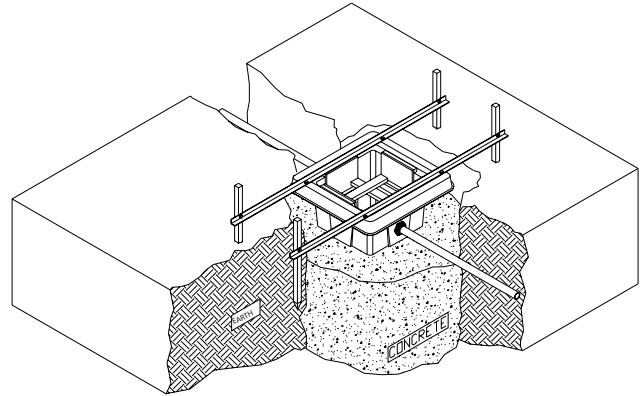

PIT-0011-061599-JTR

## 13. **PREPARE**

the surface for the final concrete pour.

- Compact the foundation.
- Using gravel, cover plumbing trenches and slope the wash pad area at approximately 1/8" per foot toward the catch basins.
- Place ready rod in grid formation to form the complete wash pad area.

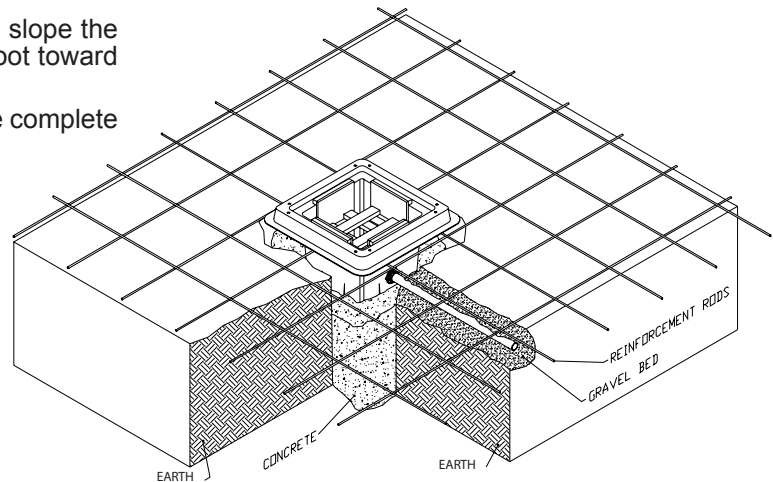

PIT-0012-061599-JTR

## 14. **POUR**

the third and final phase of concrete according to state and local codes using 4" minimum . Pour around the pit housings first, "locking" the pit in place. Your Mi-T-M pits are constructed with a unique lip design that allows the concrete to literally form a wall between the pit and the surface. This wall of concrete will prohibit seepage around the surface of the pit. (See comparison drawing below). Once the pit perimeters have been poured, distribute concrete throughout the remaining wash pad area. Allow to cure.

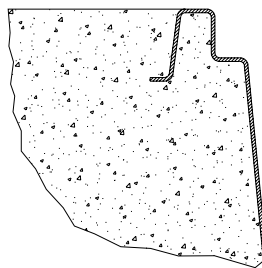

**Mi-T-M**



**OTHER**

## 15. **GROUT**

any exposed areas around the edges of the pits. If your pits were installed using an existing concrete surface, be sure to fill the holes created by the lag bolts used during the bracing procedures.

## 16. **CLEAN**

the interior of the pits and place your choice of Mi-T-M polished aluminum diamond plate covers or steel grates on the pits.

# ACCESSORIES

**COALESCING PACKS** for 3-Stage Collection Pit.....#855-0013

**BULKHEAD FITTINGS**

3" slip x FNPT .....#55-2248  
 4" slip x FNPT .....#55-2448

**COVERS:**

2 x 2 Diamond Plate.....#56-0030  
 3 x 3 Diamond Plate.....#56-0031  
 3 x 9 Diamond Plate (3 Sections) .....#56-0032  
 2 x 2 Steel Grate .....#20-0479-A01  
 3 x 3 Steel Grate (Qty. 2 required).....#20-0480-A01

## OPTIONAL ACCESSORY SPECIFICATIONS

USED ON:	PIT 3 x 3 12-0071	PIT 3 x 9 12-0074	PIT 2 x 2 12-0073
COVER CONSTRUCTION	Aluminum Polished Diamond Plate	Aluminum Polished Diamond Plate	Aluminum Polished Diamond Plate
SUPPORT STRENGTH	450 lbs.	450 lbs.	450 lbs.
DIMENSIONS L x W x H	36 x 36 x 2	36 x 110 x 2	24 x 24 x 2
NET WEIGHT (lbs.)	30	83	16
<b>NOTE: COVERS ARE NOT DESIGNED FOR VEHICLE TRAFFIC</b>			
COVER CONSTRUCTION	Steel Grate	--	Steel Grate
SUPPORT STRENGTH	4,814 lbs/ft <sup>2</sup>	--	7,316 lbs/ft <sup>2</sup>
DIMENSIONS L x W x H	17.5 x 36 x 2.5 each	--	24 x 24 x 2
NET WEIGHT (lbs.)	62 each (2 required)	--	96

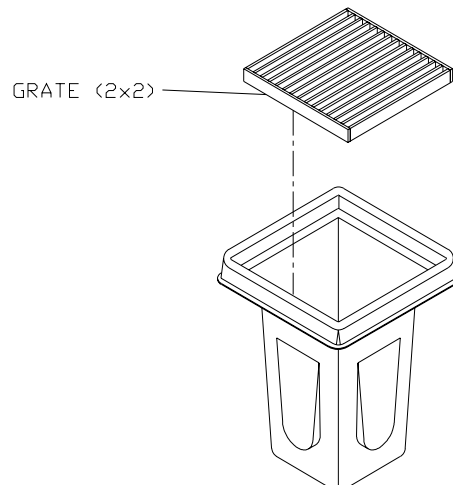
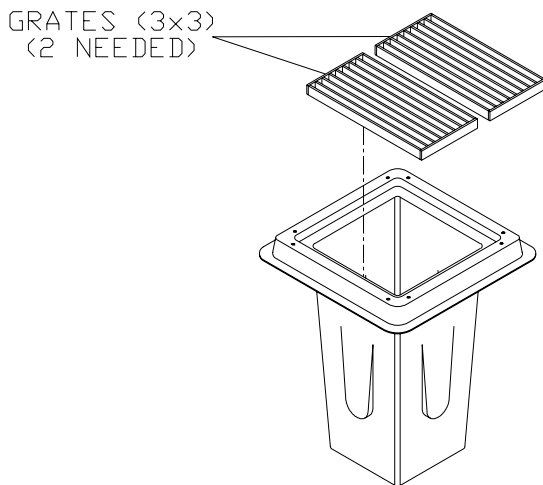

PIT0018-060299-JTR

PIT0017-060299-JTR



## COVER FOR 2x2 12-0073 PIT

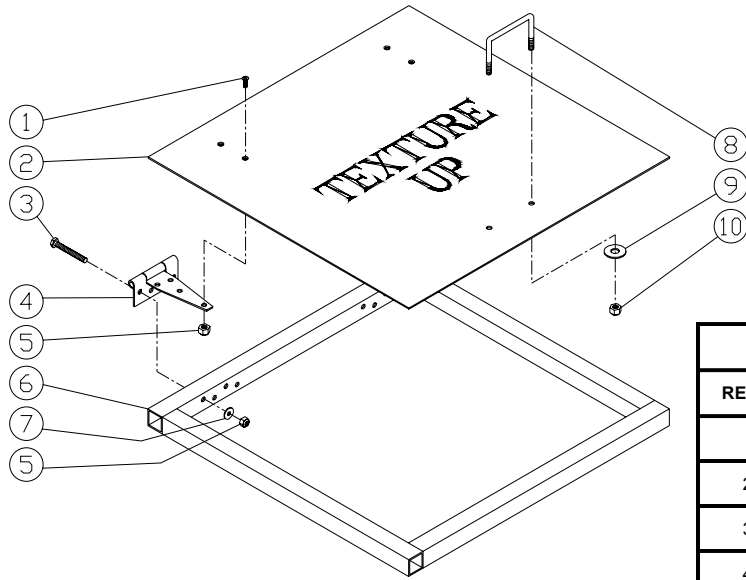

PIT0014-060299-JTR

COVER FOR 2x2 SUMP PIT			
REF. #	DESCRIPTION	PART #	QTY.
1	Screw	27-8932	4
2	Lid	50-003004	1
3	Bolt	27-05014	8
4	Hinge	33-0310	2
5	Locknut	30-5155	12
6	Frame	56-003001	1
7	Washer	28-0121	8
8	Handle	33-0311	1
9	Washer	28-0123	2
10	Locknut	30-5159	2

PIT-0014-060299-JTR

## COVER FOR 3x3 12-0071 PIT

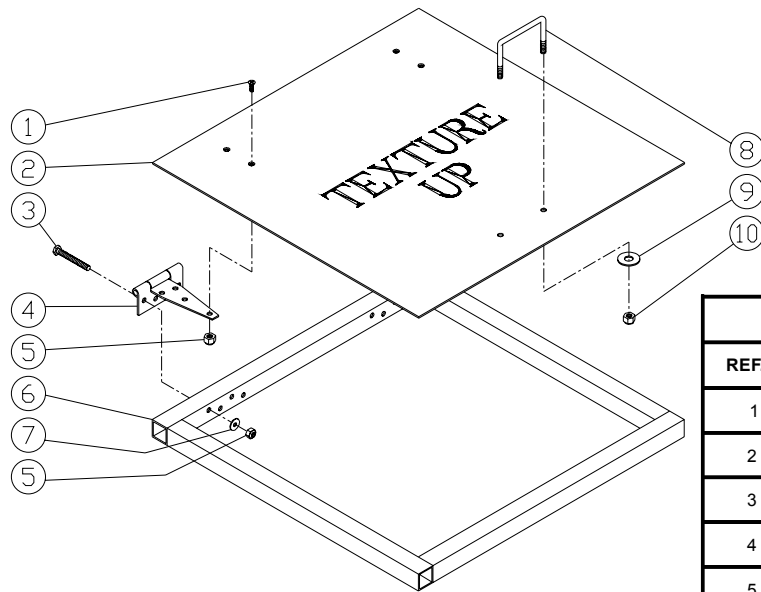

PIT0015-060299-JTR

COVER FOR 3x3 CATCH BASIN PIT			
REF. #	DESCRIPTION	PART #	QTY.
1	Screw	27-8932	4
2	Lid	50-003104	1
3	Bolt	27-5014	8
4	Hinge	33-0310	2
5	Locknut	30-5155	12
6	Frame	56-003101	1
7	Washer	28-0121	8
8	Handle	33-0311	1
9	Washer	28-0123	2
10	Locknut	30-5159	2

PIT-0015-060299-JTR

# COVER FOR 3x9 12-0074 3-STAGE COLLECTION PIT

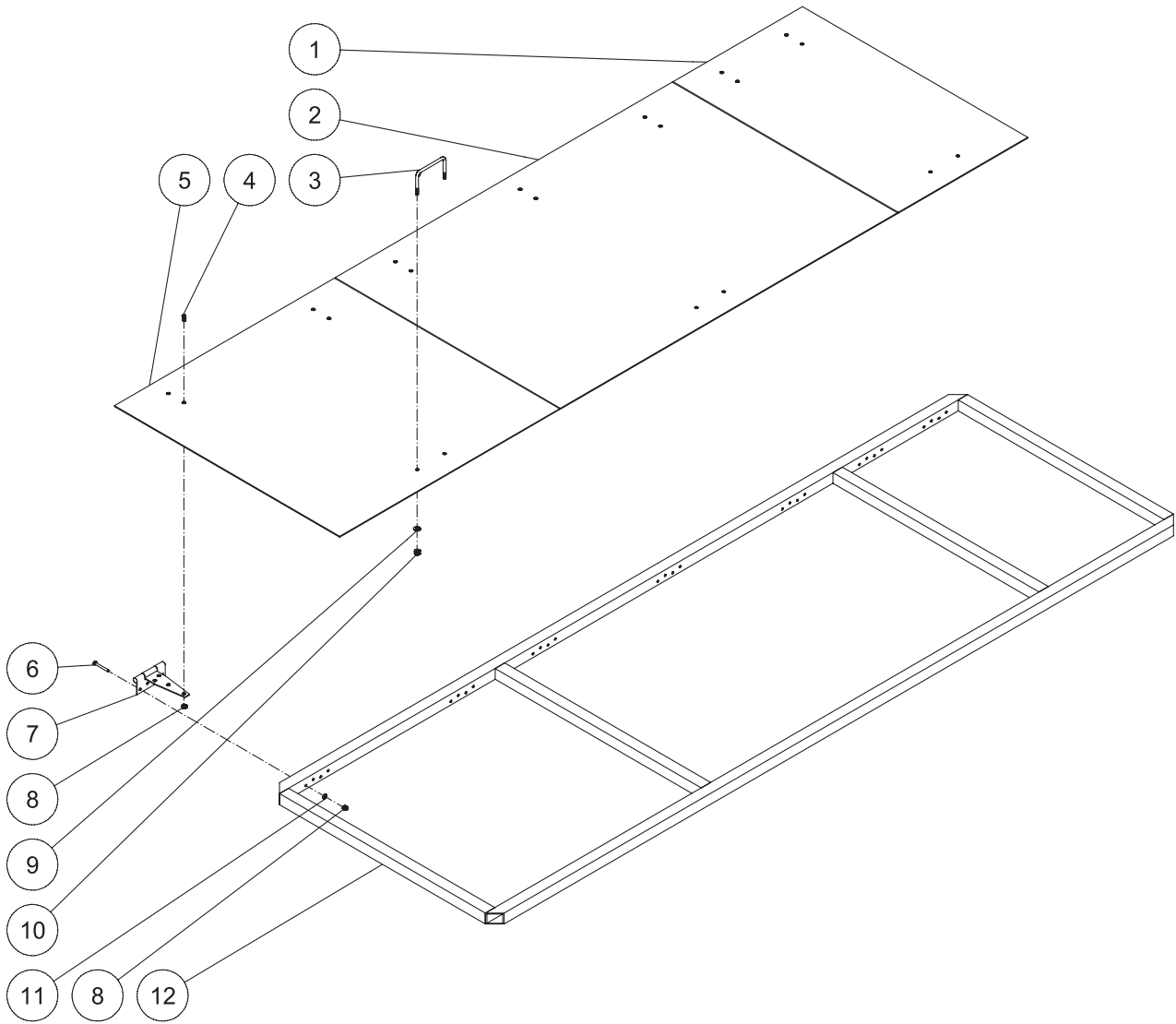

56-0032 083106

PIT-0016-060299-JTR

PIT0016-083106-PJH			
COVER FOR 3x9 3-STAGE COLLECTION PIT			
REF. #	DESCRIPTION	PART #	QTY.
1	Lid-Small	56-03205	1
2	Lid-Large	56-03207	1
3	Handle	33-0311	3
4	Screw	27-8932	14
5	Lid-Medium	56-03206	1
6	Bolt	27-5014	28
7	Hinge	33-0310	7
8	Locknut	30-5155	42
9	Washer	28-0123	6
10	Locknut	30-5159	6
11	Washer	28-0121	28
12	Frame	56-003201	1



## STATEMENT OF WARRANTY

Mi-T-M warrants all parts (except those referred to below) of your new In-ground Fiberglass Pit System to be free from defects in materials and workmanship for one year from the date of original purchase.

Defective parts not subject to normal wear and tear will be repaired or replaced at Mi-T-M's option during the warranty period. In any event, reimbursement is limited to the purchase price paid.

### EXCLUSIONS

1. Normal wear parts:
  - Seals
  - Gaskets
  - O-rings
2. Parts damaged due to:
  - normal wear, misapplication, modifications/alterations, abuse,
  - operation at other than recommended temperature,
  - the use of caustic liquids,
  - chloride corrosion or chemical deterioration,
  - fluctuations in water supply,
  - operating unit in an abrasive, corrosive or freezing environment.
3. Parts damaged by failure to follow recommended:
  - installation, operating and maintenance procedures.
4. This warranty does not cover the cost of:
  - normal maintenance or adjustments,
  - labor charges,
  - transportation charges to Service Center,
  - freight damage.
5. The use of other than genuine Mi-T-M parts will void warranty. Parts returned, prepaid to Mi-T-M's factory or to an Authorized Service Center will be inspected and replaced free of charge if found to be defective and subject to warranty. There are no warranties which extend beyond the description of the face hereof. Under no circumstances shall Mi-T-M bear any responsibility for loss of use of the unit, loss of time or rental, inconvenience, commercial loss or consequential damages.

